

5.5.18. Cylinder Head Cover

- Loosen and remove 4 Nos. Hex flange head bolts **(M5) (a)** in crisscross pattern along with the rubber seals and washers.

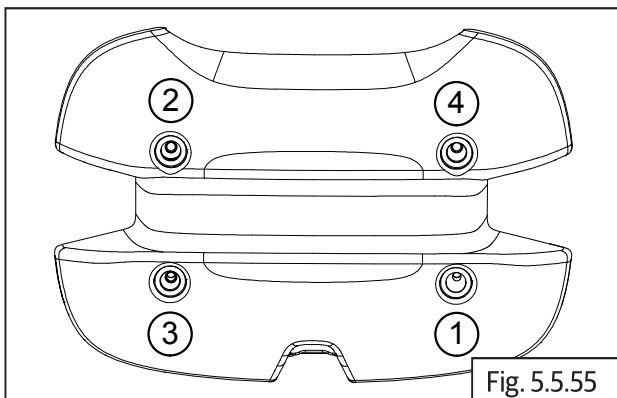

- Gently remove rocker cover **(a)** from cylinder head **(b)**.

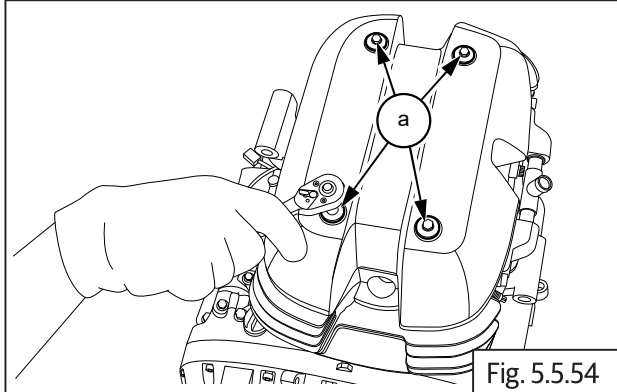
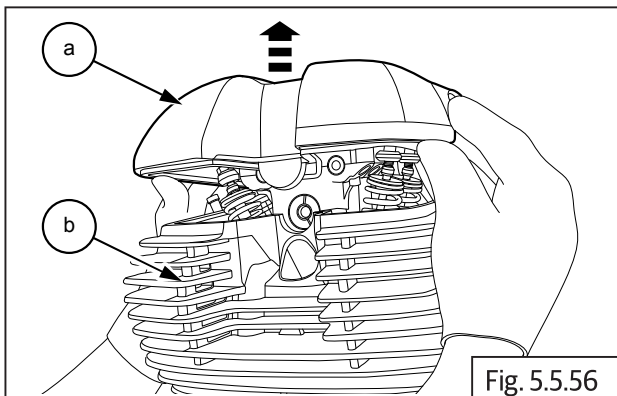

- Remove rubber gasket **(a)** from cylinder head cover **(b)**.

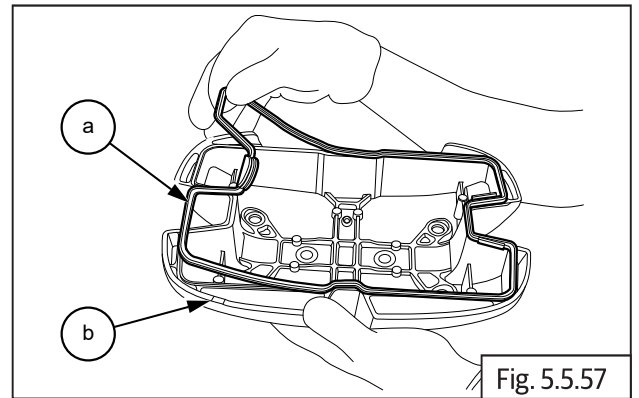

5.5.19. Crankshaft Plug on Magneto Cover

- Remove crankshaft hole plug **(M34) (a)** from center of magneto cover **(b)**.

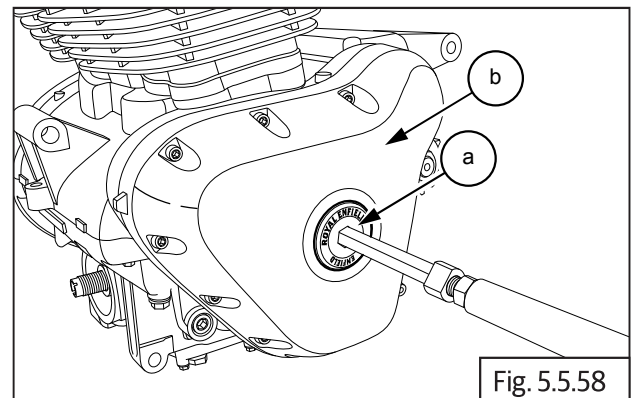

- Remove O-ring **(a)** from crankshaft hole plug **(b)**.

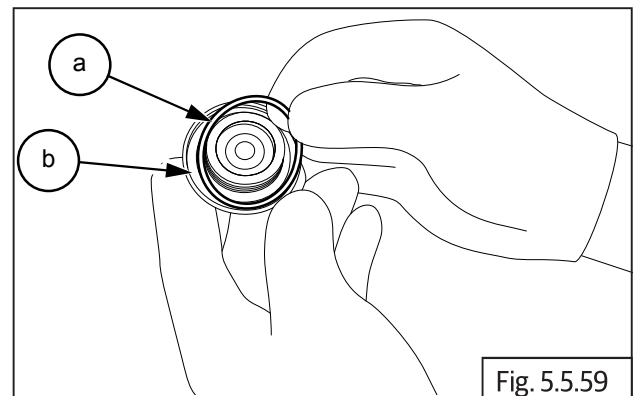

5.5.20. Rocker Carrier LH Cylinder

- Locate 17mm socket with ratchet **(a)** on the magneto rotor bolt inside the plug hole and rotate magneto rotor in clockwise direction till reference mark "L" on camshaft LH side is aligned with machined gasket surface on cylinder head.

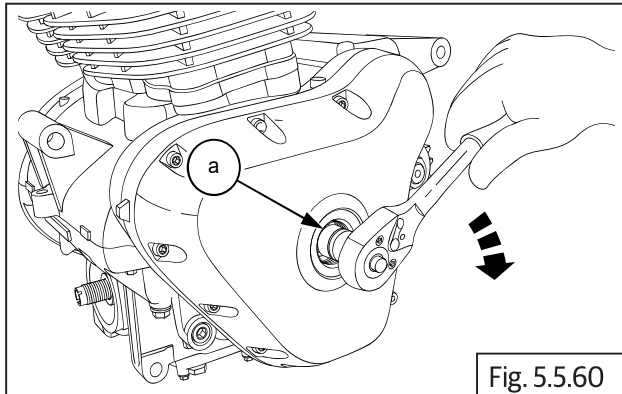

17 mm Socket with Ratchet

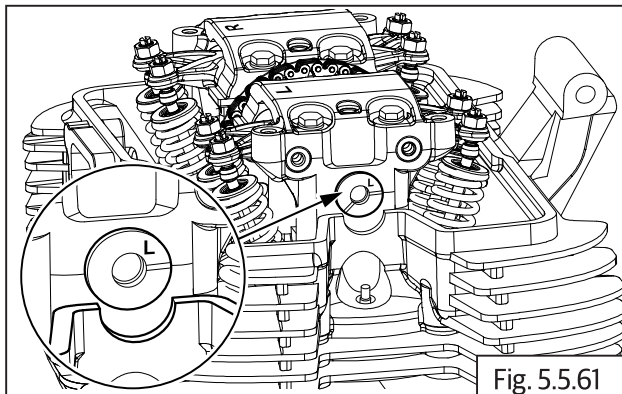

- Loosen and remove 4 Nos. Hex flange head bolts **(M6) (a)** from rocker carrier.

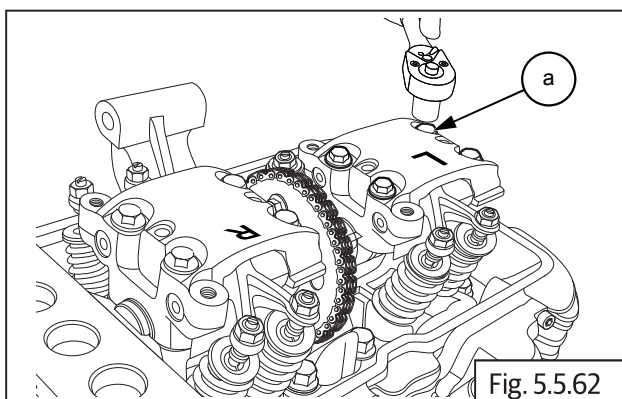

10 mm Socket with Ratchet

- Gently remove the rocker carrier **(a)** along with rocker arms from cylinder head.

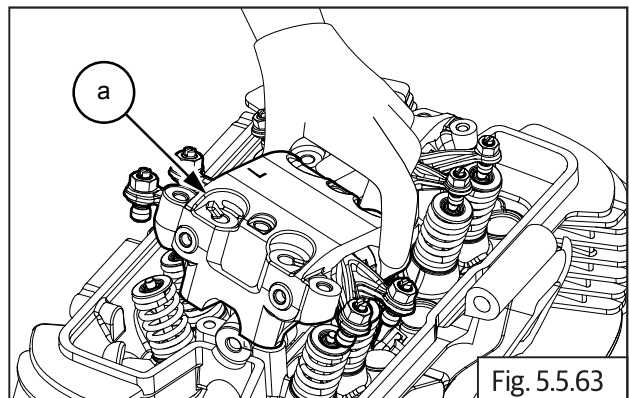

5.5.21. Rocker Carrier RH Cylinder

- Locate 17mm socket with ratchet **(a)** on the magneto rotor bolt inside the plug hole and rotate magneto rotor in clockwise direction till reference mark "R" on camshaft LH side is aligned with machined gasket surface on cylinder head.

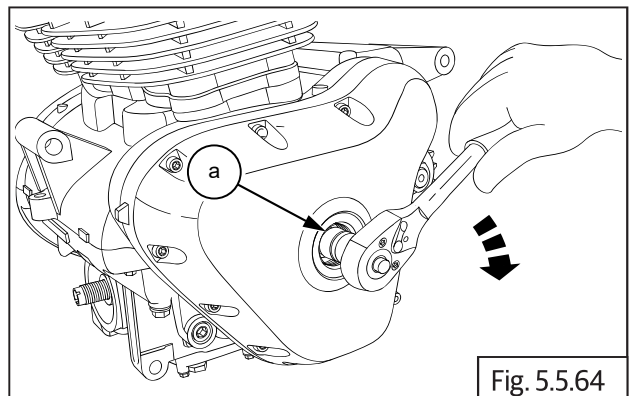

17 mm Socket with Ratchet

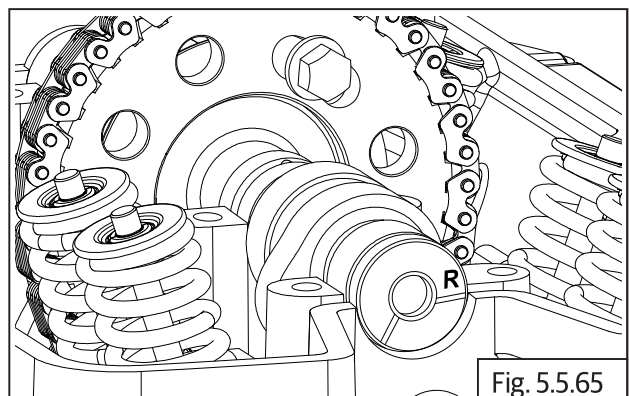

- Loosen and remove 4 Nos. Hex head bolts **(M10)** **(a)** from rocker carrier RH.

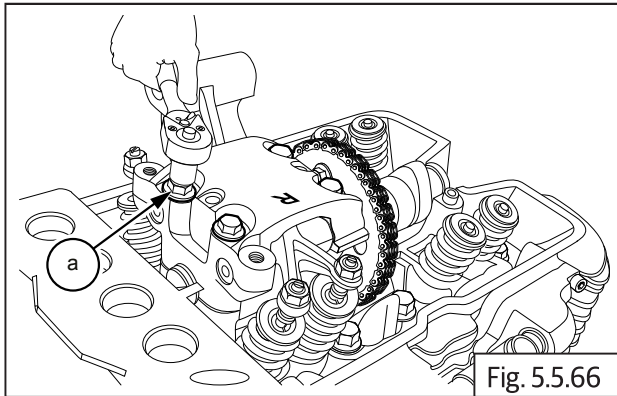

- Loosen and remove 2 Nos. Hex flange bolts **(M6)** **(a)** from cylinder barrel **(b)**.

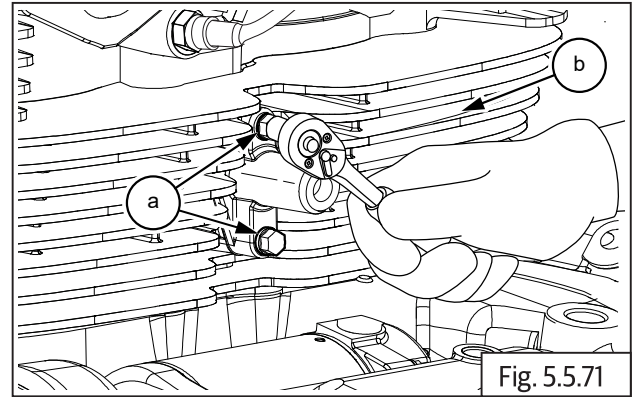

5.5.23. Timing Chain Tensioner

- Loosen and remove center Hex flange bolt **(M6)** **(a)** from cylinder barrel.

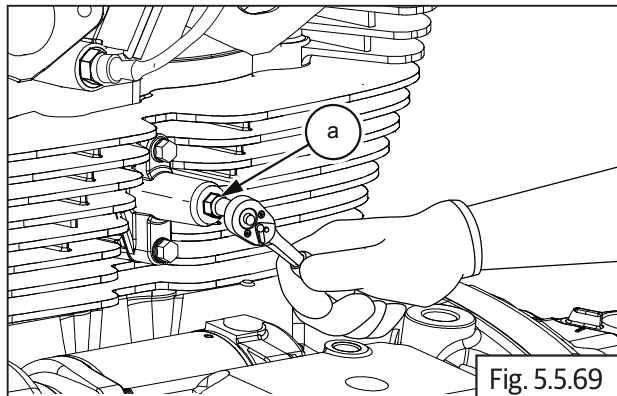

- Insert screw driver into chain tensioner housing and turn clockwise until pad is free.

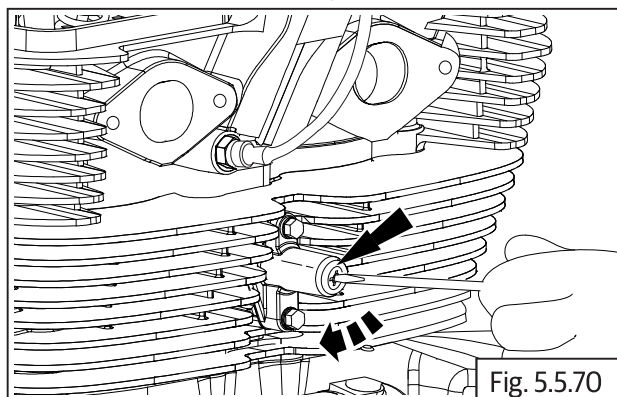

- Remove timing chain pad adjuster **(a)** from cylinder barrel.

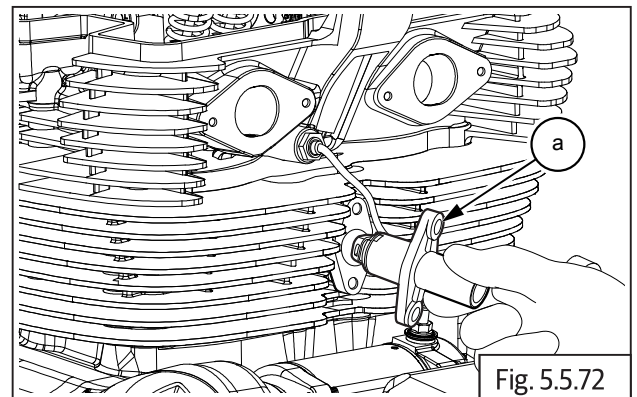

5.5.24. Cam Shaft, Sprocket & Chain

- Rotate magneto rotor in clockwise direction, till one of the Hex head bolts on cam chain sprocket appears at the top most position.

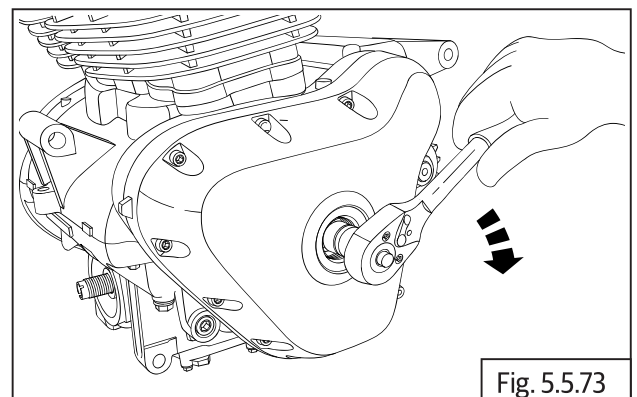

- Loosen and remove 1st Hex head bolt **(M8) (a)** from cam sprocket.

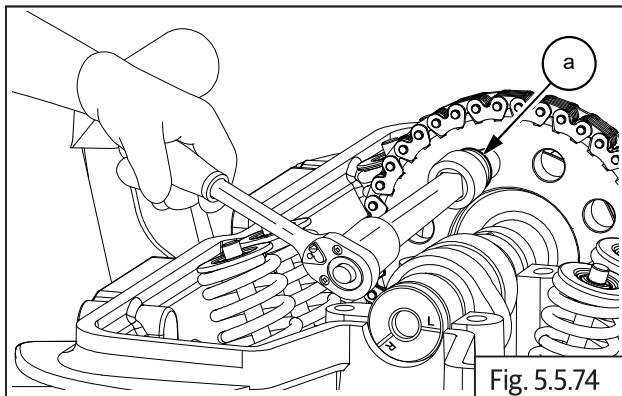

	12 mm Socket with Ratchet
--	---------------------------

- Rotate magneto rotor in clockwise direction till other bolt is visible at top most position.

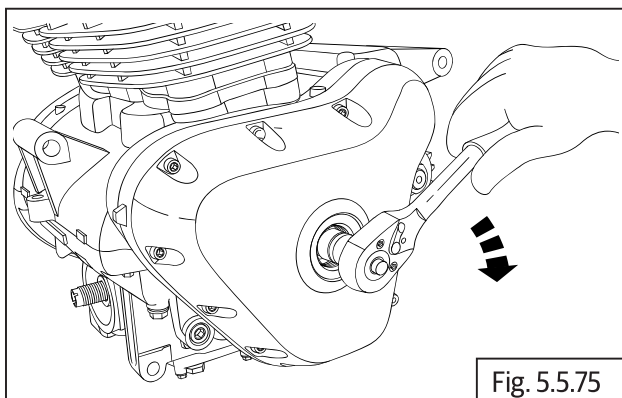

	17 mm Socket with Ratchet
--	---------------------------

- Loosen and remove 2nd Hex head bolt **(M8) (a)** from cam sprocket.

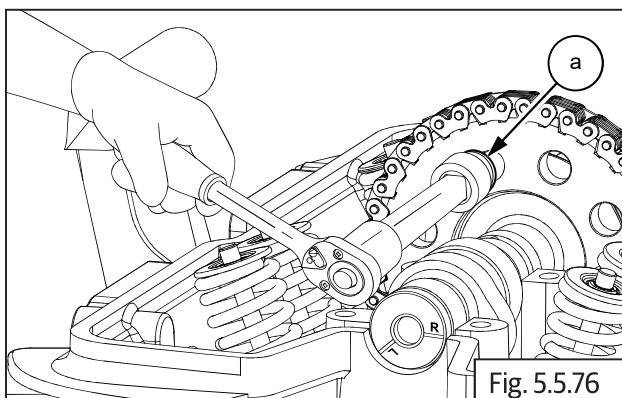

	12 mm Socket with Ratchet
--	---------------------------

- Remove "C" washer **(a)** from groove in cylinder head LH to release cam shaft.

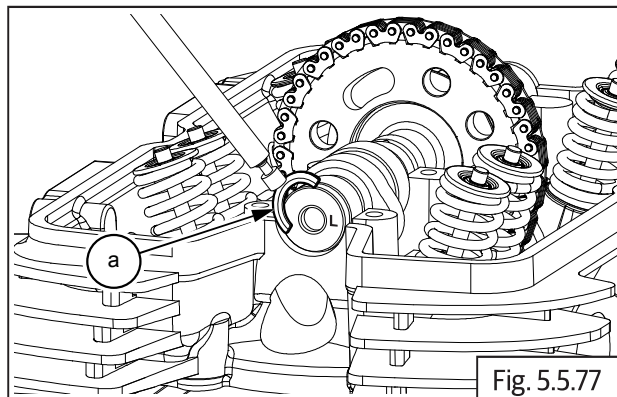

	Magnetic stick
--	----------------

- Gently release timing chain **(a)** from camshaft sprocket and remove camshaft **(b)** from cylinder head assembly.

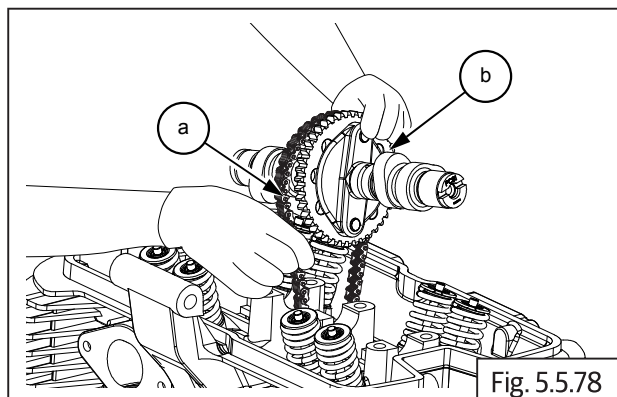

- Support timing chain suitably at the top to prevent it from dropping into the crankcase.

5.1.38. Cylinder Head

- Remove exhaust pipe and silencers LH and RH ([section 6.4.2](#)).
- Loosen and remove 8 Nos. Hex head long bolts (M10) (a) in crisscross pattern on cylinder head.

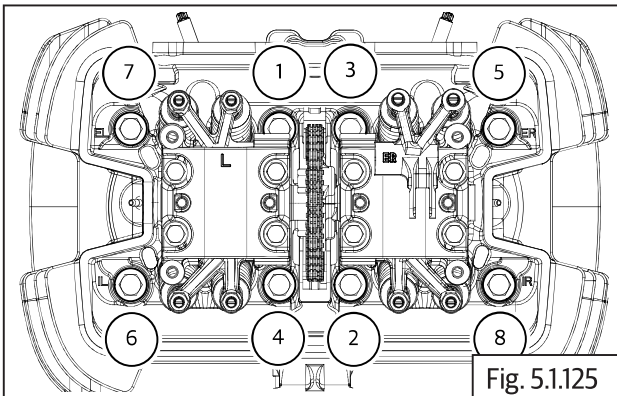
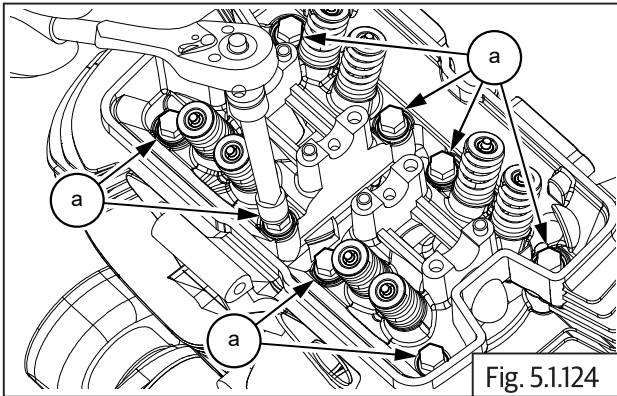

- Support cam chain suitably and gently remove cylinder head (a) from cylinder barrel (b).

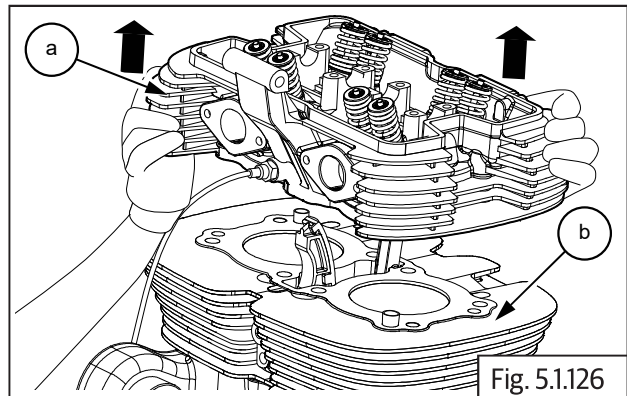

- Remove the cylinder head gasket (a) from cylinder barrel (b).

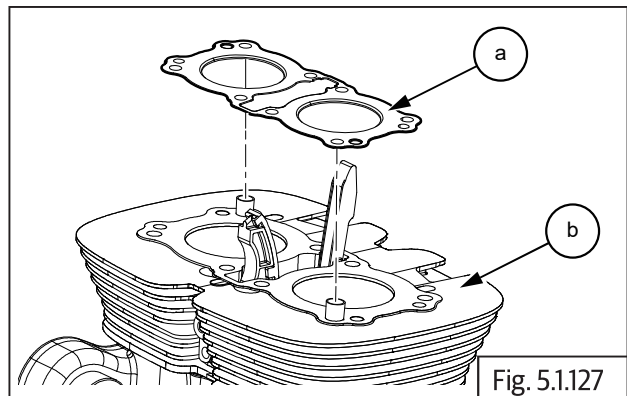

5.1.39. Components from Cylinder Head

Valves and Springs

- Compress valve spring with special tool (a).

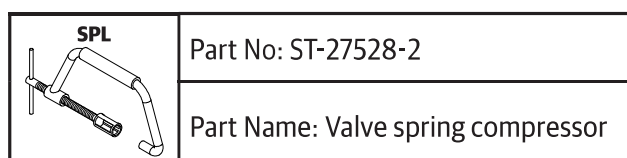
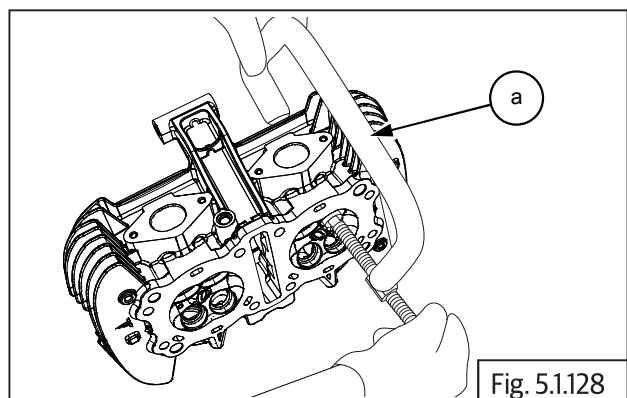

- Remove the cotters **(a)** on valve stem at the top.

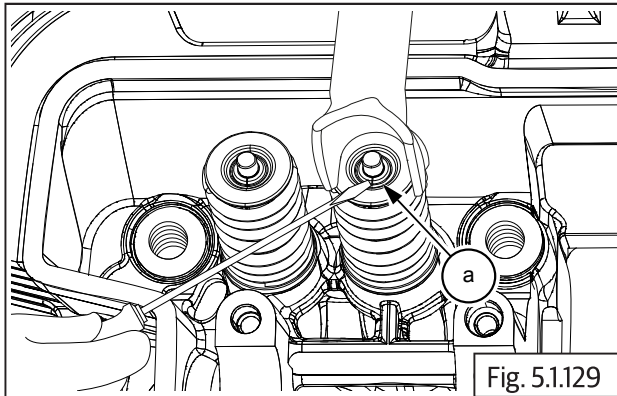

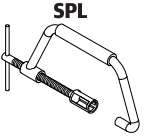
	Part No: ST-27528-2
	Part Name: Valve spring compressor

- Gently loosen the screw on valve spring compressor, till the valve spring tension is completely released and remove the special tool.

⚠ CAUTION

Valve spring under high tension when compressed.

Release valve spring compressor tool slowly and with care.

- Remove the retainer, valve spring **(a)** form the top of the valve spring **(b)**.

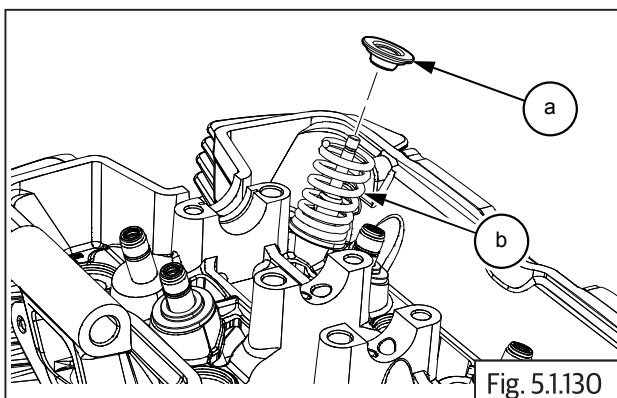

- Remove valve spring **(a)** from valve stem **(b)**.

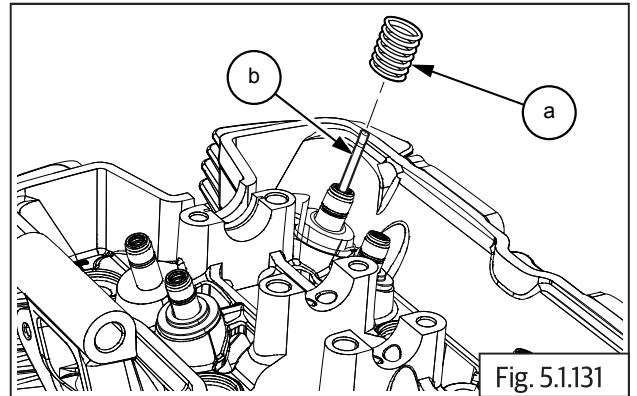

5.8.22. Components in Cylinder Head

Valves and Springs

Fit one shim from the cam kit over the valve stem seal, and then fit the valve spring seat on top of this.

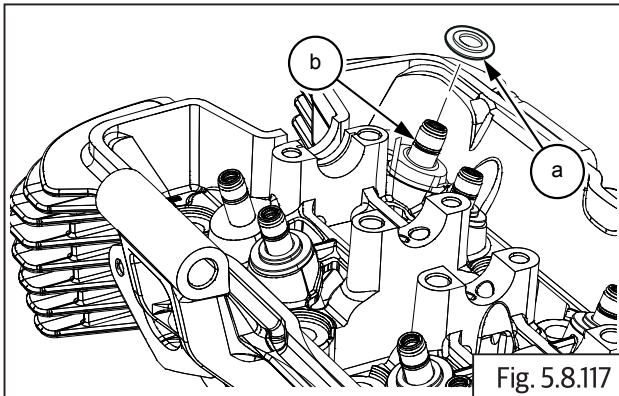

- Support the valve inside cylinder head and assemble valve spring (a) over valve stem (b) in the outer area of the cylinder head.

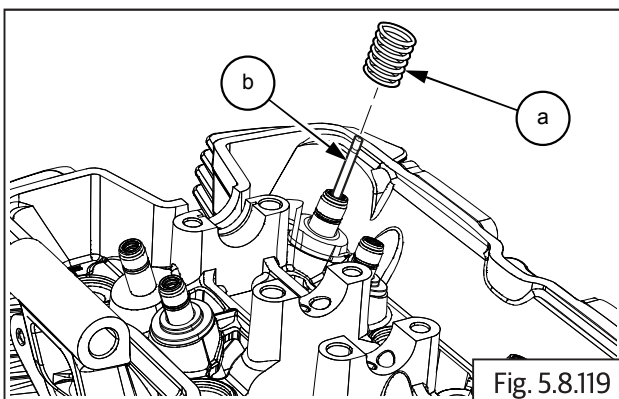

- Insert collar (a) above valve spring (b).

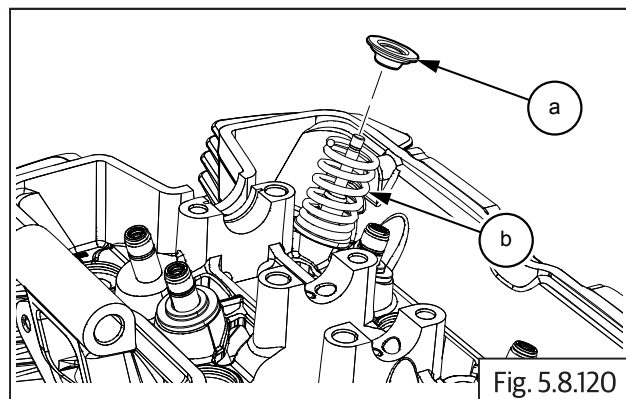

- Locate special tool on the valve such that the threaded screw end of the tool is seated centrally on the valve inside the cylinder head and the other end is seated on the valve spring collar on the outer side of the cylinder head.
- Compress valve spring with special tool (a) by "hand tightening" the threaded screw of the special tool gently, till it locks against the valve.

! CAUTION

Do not overtighten the special tool as it will damage both the valve seating surface and the special tool.

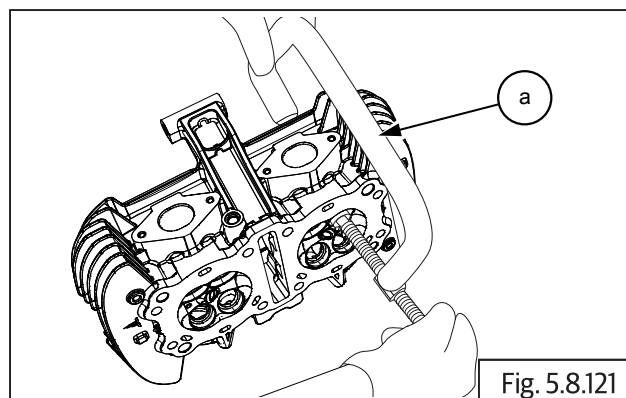

SPL

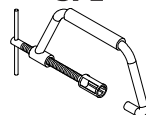

Part No: ST-27528-2

Part Name: Valve spring compressor

- Locate two split cotters **(a)** on the collar with their tapered end facing inside and the flat edges seated against the valve stem top portion.

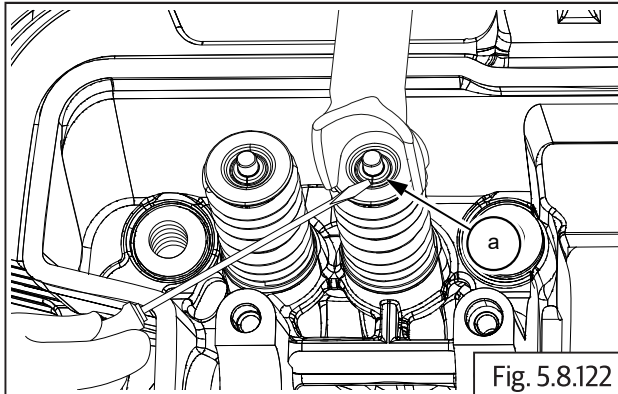
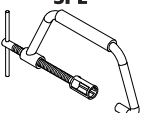

Fig. 5.8.122

	Part No: ST-27528-2
	Part Name: Valve spring compressor

- Gently and slowly release special tool by unscrewing the threaded shaft, duly ensuring the valve cotters are locked in place on the valve stem and the tapered surfaces of the cotters are inside the valve spring collar.
- Remove special tool **(a)** from the valve.

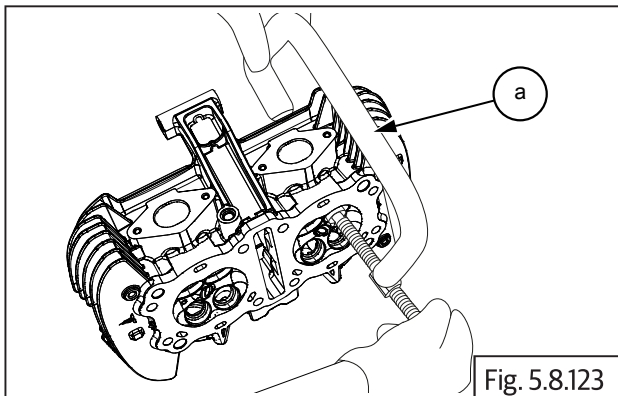

Fig. 5.8.123

- Repeat the above process to install the other seven valves, springs, collars and cotters on the cylinder head.

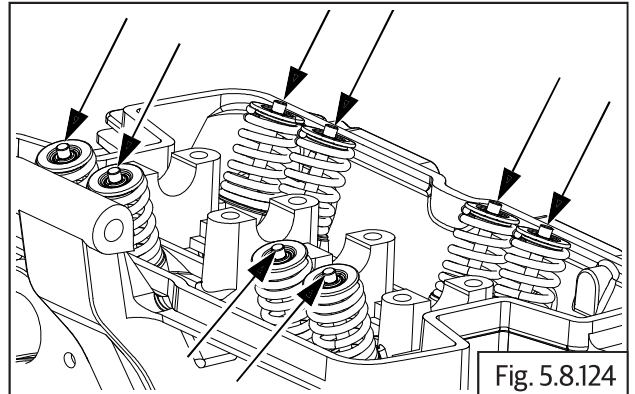

Fig. 5.8.124

5.8.23. Cylinder Head on Cylinder Barrel

Cylinder head assembly on cylinder barrel

- Position cylinder head over the barrel such that the exhaust ports are facing towards the front and inlet ports are towards the rear of the engine.
- Ensure the 2 Nos. dowels **(a)** and cylinder head gasket are located on the cylinder barrel.
- Ensure the cam chain pads are positioned correctly and route the cam chain from the lower side of the cylinder head to the top.
- Support cam chain suitably to prevent it from falling into cylinder head.

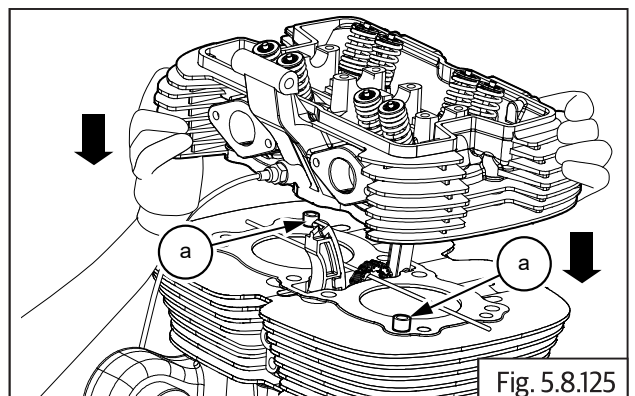
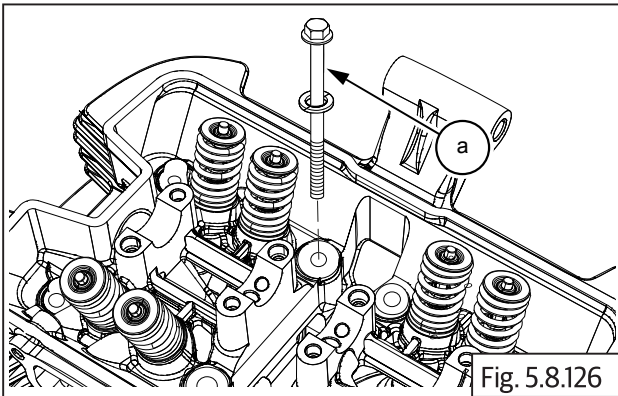

Fig. 5.8.125

! CAUTION

Cylinders bolts are pre-coated and hence should be used one time only. Do not reuse.

- Locate new 8 Nos. Hex flange head bolts **(M10) (a)** along with washers on the cylinder head.



12 mm Socket with Ratchet

- Tighten the cylinder head bolts in a crisscross pattern to the initial 1st torque values **FIRST** and then to the 2nd torque values as specified below.

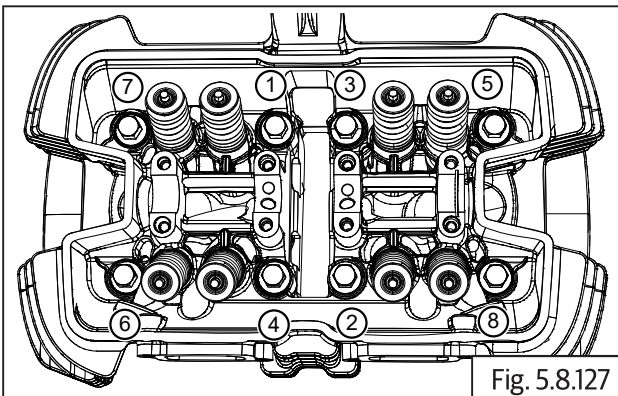

- Finally tighten each of the cylinder head bolts using an angular torque wrench, to the specified angular torque value given below and in the same crisscross pattern detailed above.

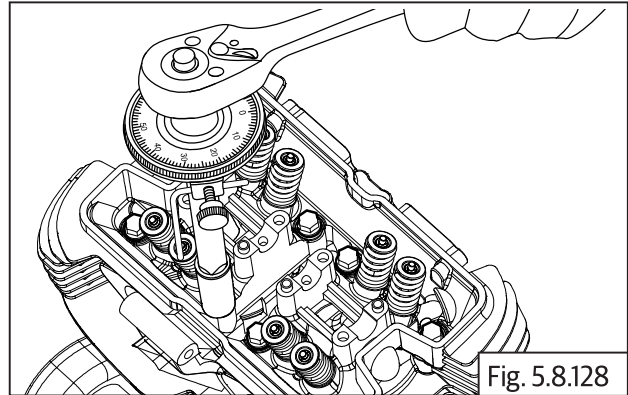

14 mm Socket with Angle wrench

1 st Torque	15 N-m/1.5 kgf-m
2 nd Torque	35 N-m/3.5 kgf-m
Angular Torque	270° (deg)

! CAUTION

Torque and angle should be as specified. Do not provide over-torque as it will damage the bolts.

5.8.28. Camshaft Sub-Assembly

- Hold the timing chain in stretched condition and gently rotate crankshaft clockwise to bring LH piston to TDC.

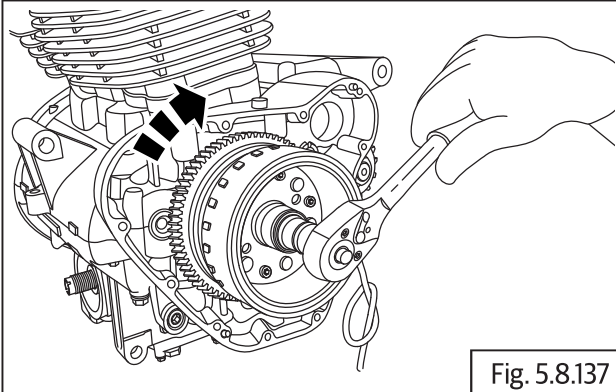

17 mm Socket with Ratchet

! CAUTION

Do not rotate crankshaft anti-clockwise.

- Hold sprocket in position with one of the slotted holes facing on top.

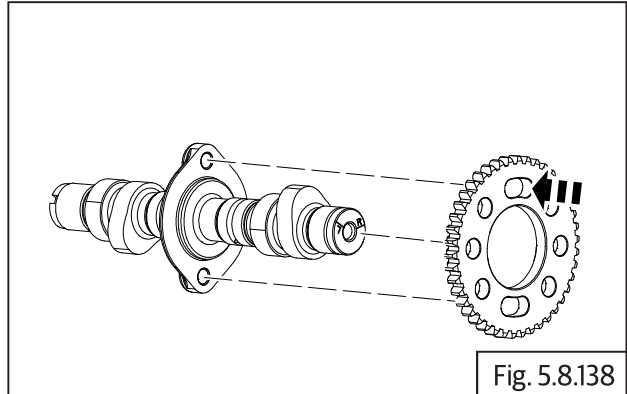

- Assemble cam chain **(a)** on sprocket and locate camshaft **(b)** into sprocket from the RH side.

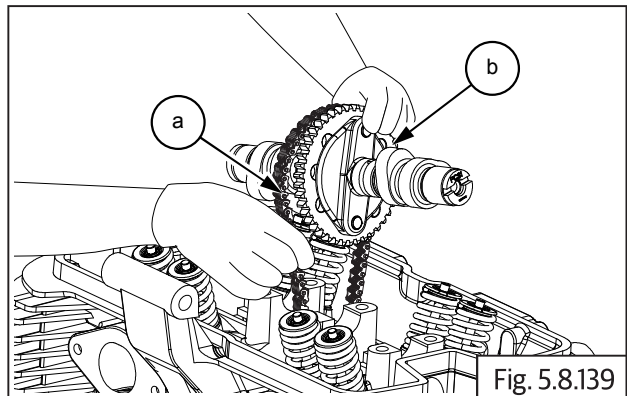

- Ensure reference mark "L" in the camshaft is aligned to the cylinder head on LH side.

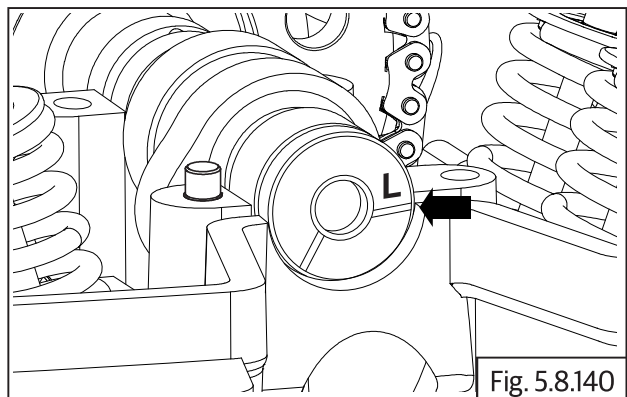

- Ensure the **flat edge** of the special tool **(a)** is correctly located in the slot on the camshaft on RH side and the tool is resting correctly on the cylinder head.
- Gently rotate crankshaft to ensure proper seating of the tool in the camshaft slot and cylinder head.

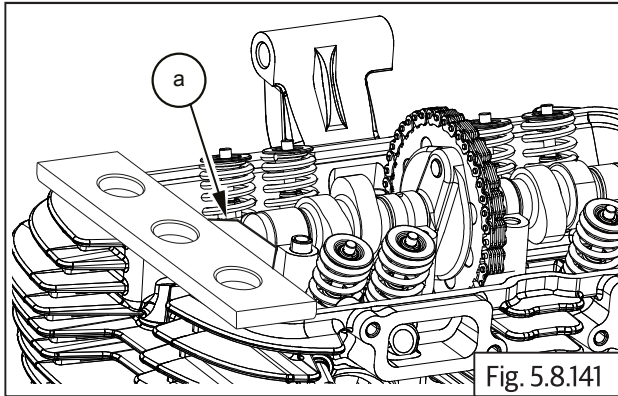

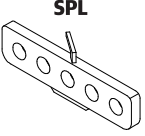
	Part No: ST-27546-1
	Part Name: Cam - TDC Aligning Plate

- Locate timing chain sprocket on camshaft with its mounting slot centralised to the threads in the camshaft.
- Locate and tighten Hex head bolt **(M8) (a)** sufficiently on timing chain sprocket. **Do not TIGHTEN FULLY.**

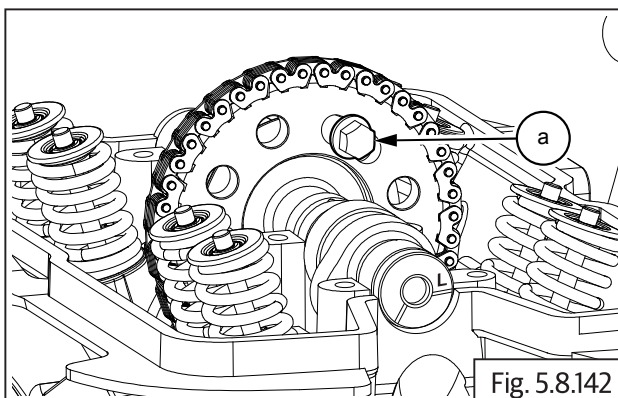

	12 mm Socket with Torque wrench
---	---------------------------------

- Remove the special tool from the camshaft on RH side.
- Rotate magneto **(a)** till another slotted hole on cam chain sprocket is at top most position. Ensure reference mark "R" aligned to the cylinder head.

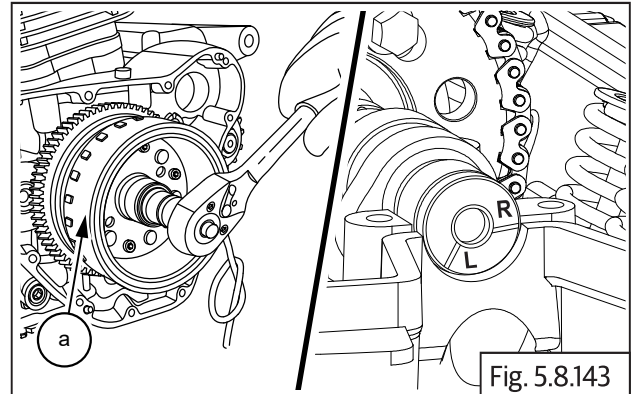

	17 mm Socket with Ratchet
--	---------------------------

- Ensure the **angular edge** of the special tool **(a)** is correctly located in the slot on the camshaft on RH side and the tool is resting correctly on the cylinder head.
- Gently rotate camshaft, if necessary, to ensure proper seating of the tool in the camshaft slot and cylinder head.

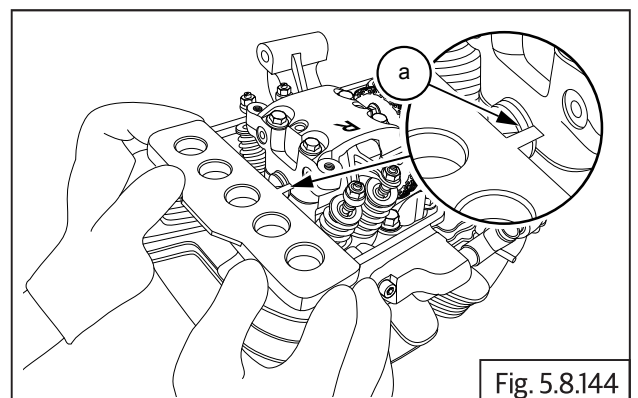

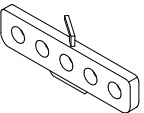
	Part No: ST-27546-1
	Part Name: Cam - TDC Aligning Plate

- Tighten Hex head bolt **(M8) (a)** to specified torque.

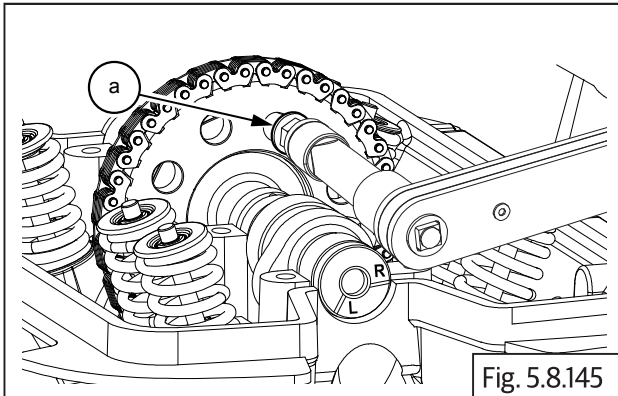



Fig. 5.8.145

	12 mm Socket with Torque wrench
Torque	35 N-m/3.5 kgf-m

- Remove the special tool from cylinder head on RH side.
- Rotate the magneto **(a)** clockwise till the first bolt is visible at top most position on cam side sprocket.

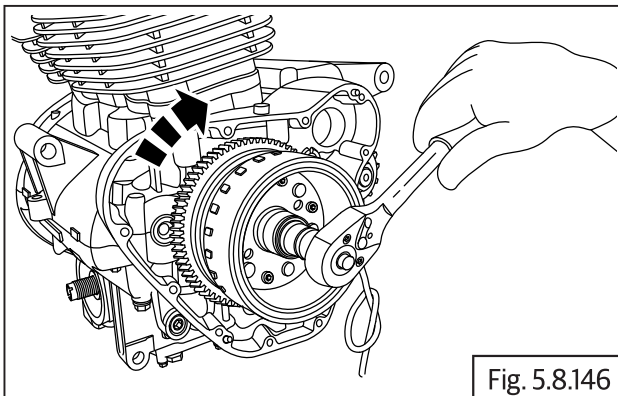

Fig. 5.8.146

- Ensure reference mark "L" in the camshaft is aligned to the cylinder head on LH side.

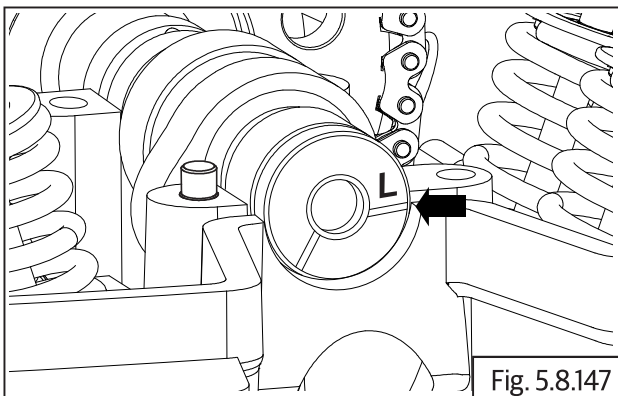

Fig. 5.8.147

- Tighten Hex head bolt **(M8) (a)** to specified torque.

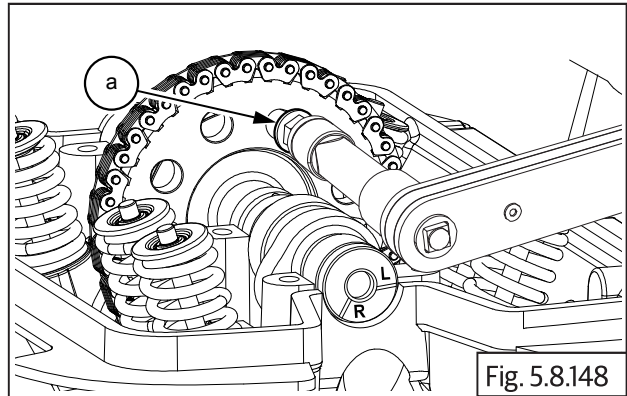



Fig. 5.8.148

	12 mm Socket with Torque wrench
Torque	35 N-m/3.5 kgf-m

- Locate and fit "C" washer **(a)** on camshaft.

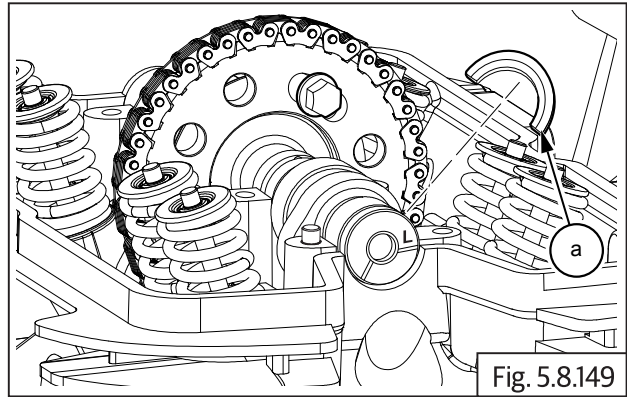

Fig. 5.8.149

5.8.29. Timing Chain Tensioner

- Ensure center bolt is removed from timing chain tensioner.
- Insert screw driver into timing chain tensioner adjuster **(a)** and loosen screw completely to release spring tension.

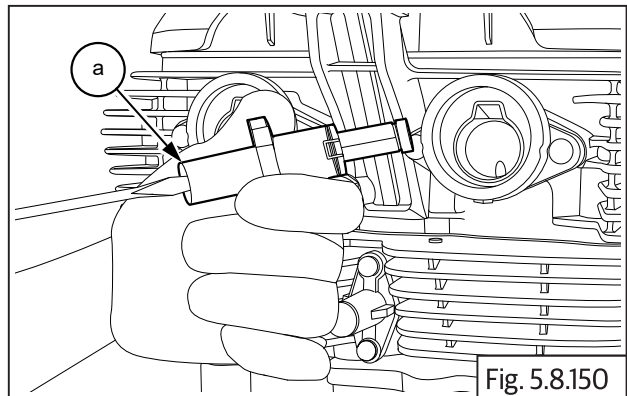
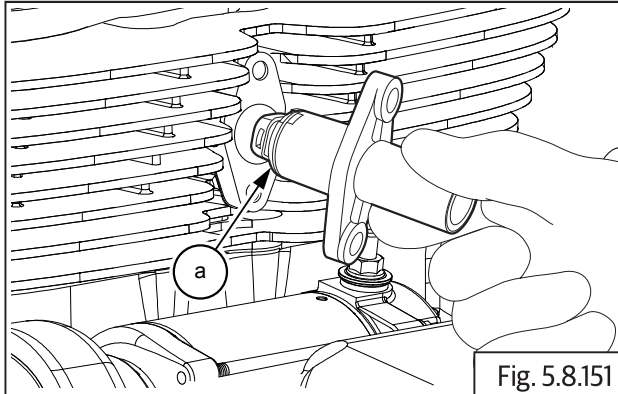

Fig. 5.8.150

	Screw driver
---	--------------

- Assemble new gasket on chain tensioner adjuster **(a)**. Ensure the foot is fully retracted into chain tensioner and locate chain tensioner adjuster in cylinder barrel such that the longer side of the foot is facing towards cylinder barrel RH.



- Assemble 2 Nos. Hex flange head bolt **(M6)** **(a)** on chain tensioner adjuster and tighten to specified torque.

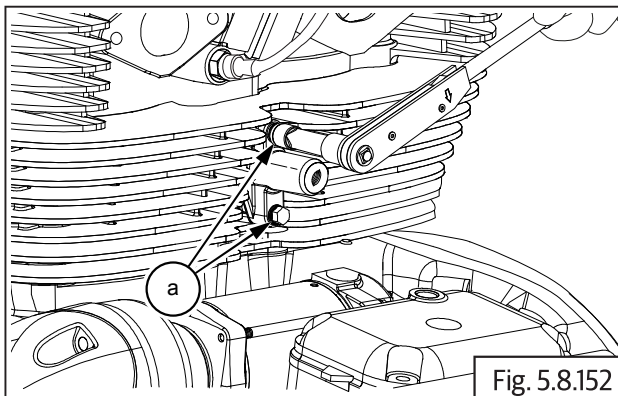

	10 mm Socket with Torque wrench
Torque	12 N-m/1.2 kgf-m

- Locate screw driver into chain tensioner adjuster **(a)** and tighten tensioner screw till it comes to a stop. **DO NOT OVERTIGHTEN.**

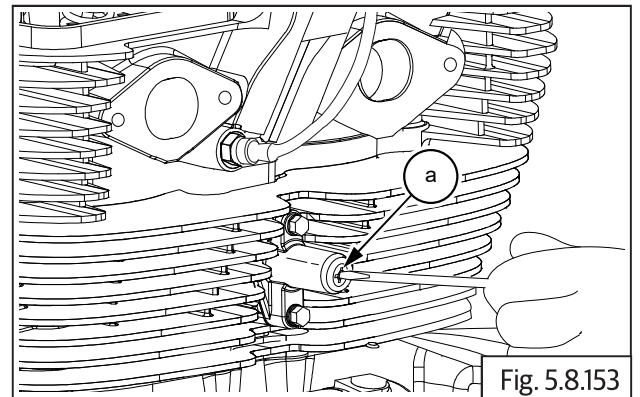

	Screw driver
--	--------------

- Locate new O-ring **(b)** and, assemble Hex flange head bolt **(M6)** **(a)** on chain tensioner adjuster and tighten fully to specified torque.

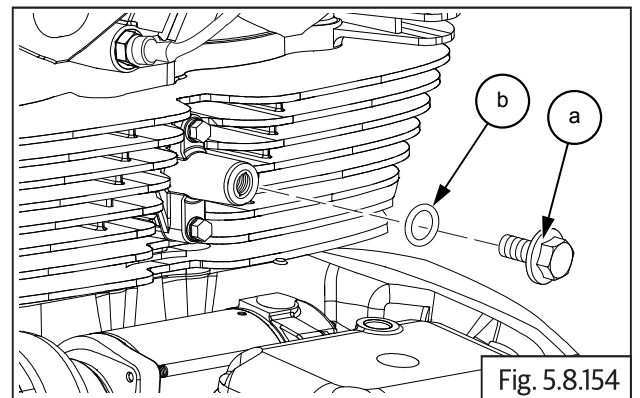

	10 mm Socket with Ratchet and Torque wrench
Torque	4 N-m/0.4 kgf-m

5.8.31. Rocker Carrier on Cylinder Head LH

- Ensure "L" mark on camshaft is aligned to cylinder head.

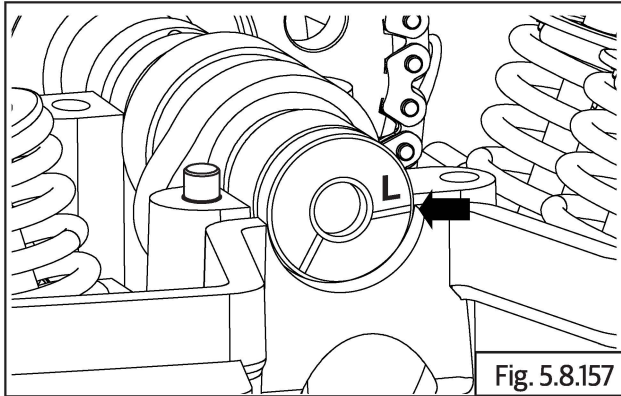

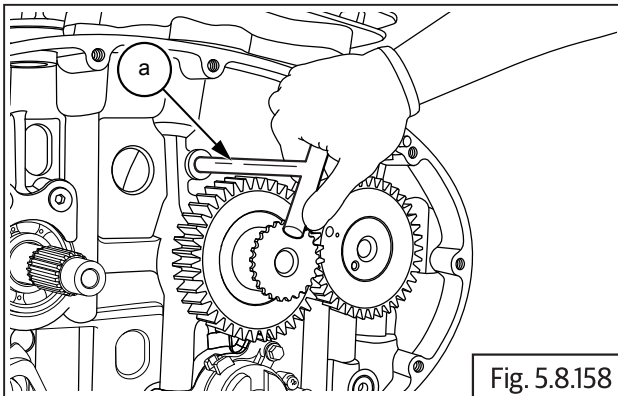

- Insert special tool **(a)** in crankcase RH to lock the crankshaft and prevent rotation.

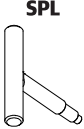

	Part No: ST-27533-2
	Part Name: Magneto and Clutch locking tool

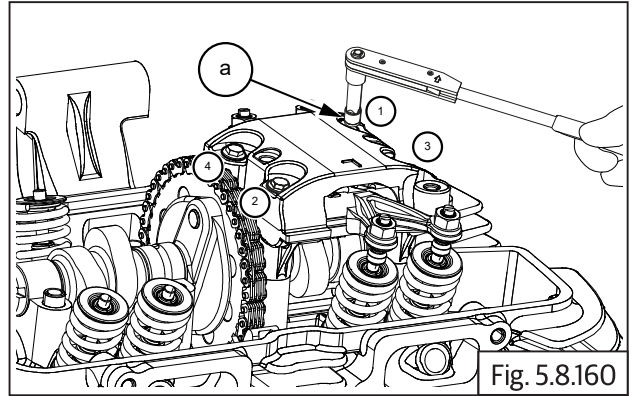
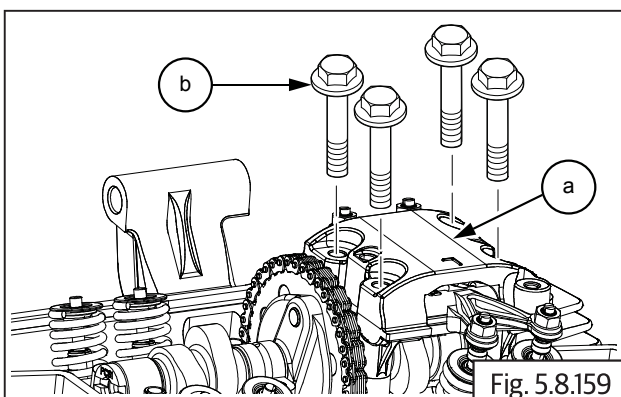
- Ensure the tappet adjuster locknuts and adjusters are fully loosened on the intake and exhaust rocker arms.
- Assemble rocker carrier LH **(a)** on cylinder head LH such that tappet adjusters are above the inlet and exhaust valves.
- Assemble 4 Nos. Hex flange head bolts **(M6)** **(b)** on rocker carrier and tighten in a crisscross pattern to torque specified torque.



	10 mm Socket with Torque wrench
Torque	12 N-m/1.2 kg-m

- Remove special tool from crankcase RH side.

5.8.32. Rocker Carrier on Cylinder Head RH

- Rotate magneto **(a)** clockwise and ensure reference mark "R" is aligned with cylinder head.

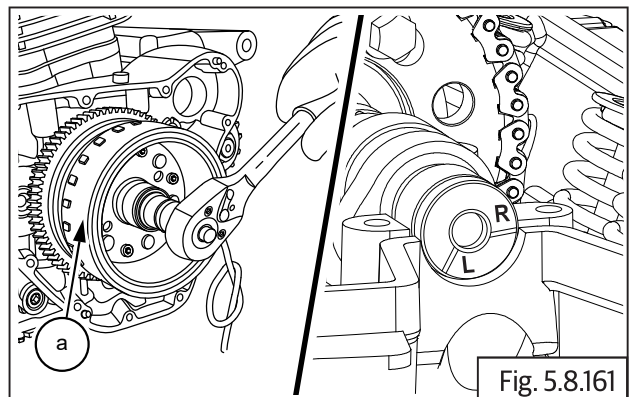

	17 mm Socket with Ratchet
--	---------------------------

- Ensure the tappet adjuster locknuts and adjusters are fully loosened on the intake and exhaust rocker arms.
- Assemble rocker carrier RH **(a)** on cylinder head RH such that the tappet adjusters are above the inlet and exhaust valves.

- Assemble 4 Nos. Hex flange head bolts (**M6**) (**b**) on rocker carrier (**a**) and tighten in a crisscross pattern to specified torque.

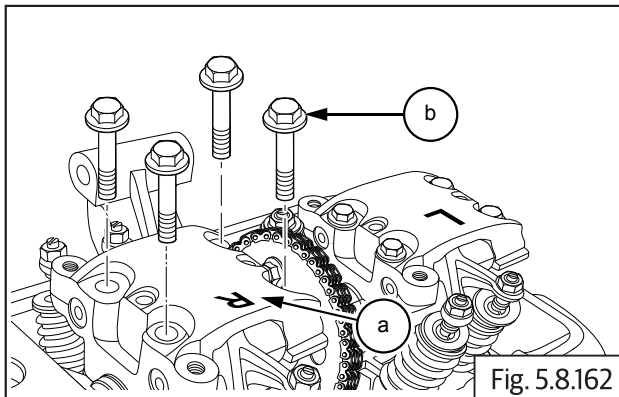

- Tighten the bolts (**a**) to specified torque.

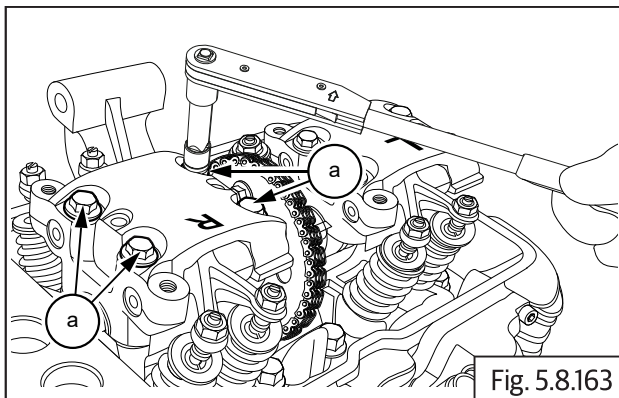

	10 mm Socket with Torque wrench
Torque	12 N-m/1.2 kgf-m

- Ensure the special tools are removed from position after tightening bolts. For tappet clearance refer [\(section 5.2.29\)](#).

5.8.33. Tappet Clearance Adjustment

Tappet Clearance Cylinder head LH

- Ensure "L" mark on camshaft (**a**) is aligned to cylinder head.

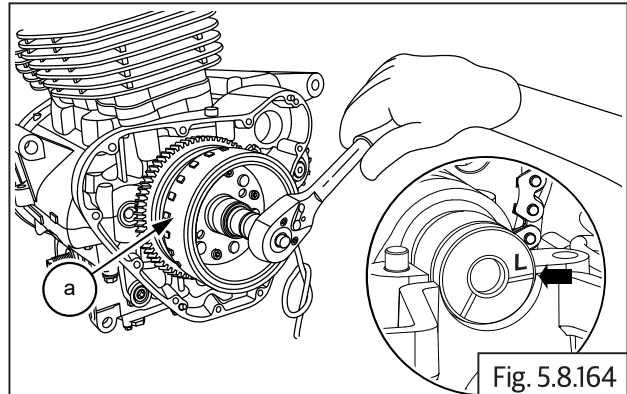

- Ensure the **flat edge** of the special tool (**a**) is correctly located in the slot on the camshaft on RH side and the tool is resting correctly on the cylinder head.
- Gently rotate crankshaft to ensure proper seating of the tool in the camshaft slot and cylinder head.

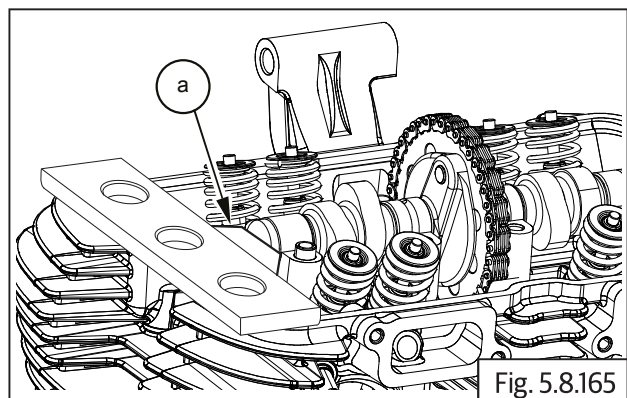

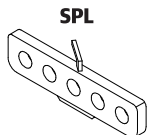
	Part No: ST-27546-1
	Part Name: Cam - TDC Aligning Plate

- Loosen tappet adjuster screw locknut **(a)** with special tool and ensure locknut is sufficiently loose.

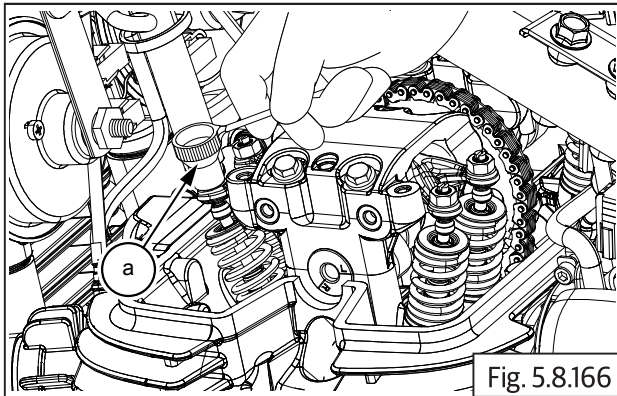

- Gently pull out feeler strip **(a)** and check if it comes out freely OR with resistance.

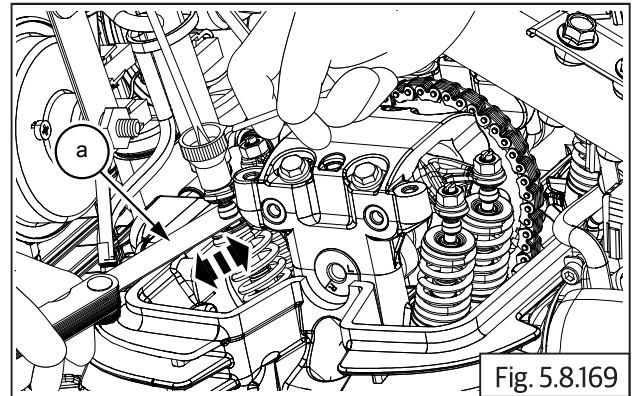

	Part No: ST-27527-2
	Part Name: Tappet adjusting tool

- Insert a screw driver into the tappet adjusting tool **(b)** and ensure it is seated correctly on the adjuster screw **(a)**.

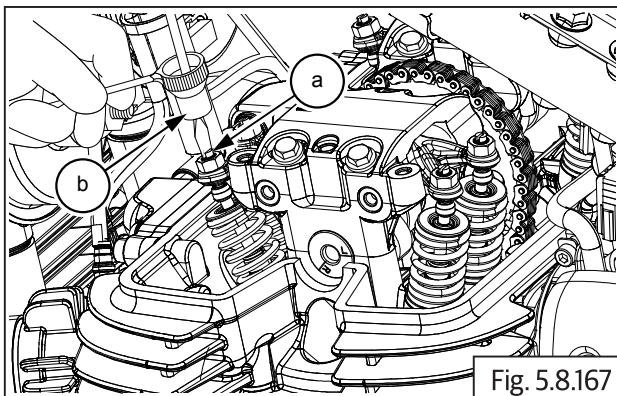

- In case feeler strip comes out freely the adjuster screw has to be tightened.
- In case feeler strip movement is hard, the adjuster screw must be loosened.
- Tighten/loosen adjuster screw using screw driver, while simultaneously checking correct and smooth movement of feeler strip.
- Ensure special tool **(a)** does not rotate while adjusting the screw.

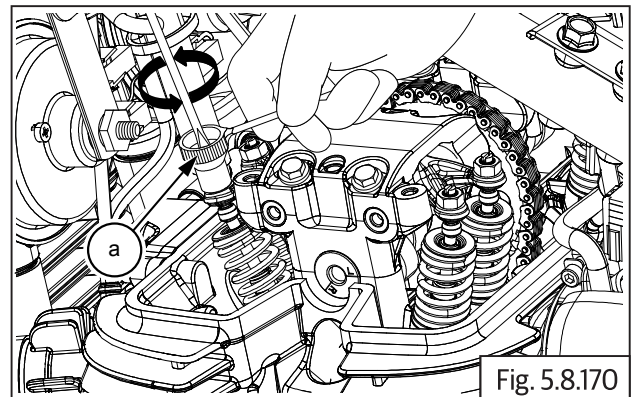

- Locate feeler strip **(a)** between adjuster screw and valve stem as per thickness mentioned below.

Inlet	0.10mm/0.125mm
Exhaust	0.15mm/0.175mm

- After setting correct gap, remove feeler strip, hold screw driver firmly such that the setting **DOES NOT** gets disturbed and gently lock the lock nut against rocker arm using special tool **(a)**.

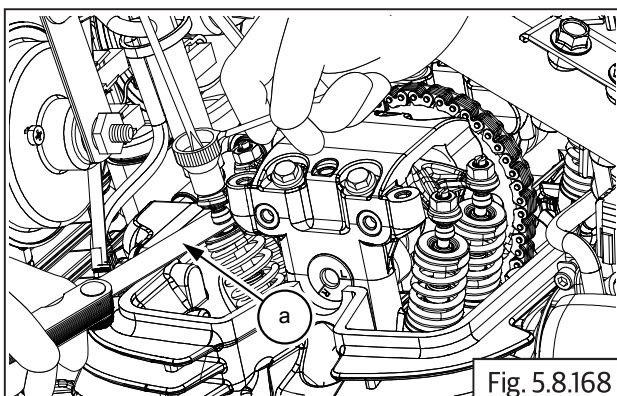



Fig. 5.8.171

NOTE

- Reconfirm correctness of tappet clearances before final locking of lock nut .

CAUTION

Do not adjust tappets with less OR no clearance as it will result in poor compression, valve burn-out and wear-out of tappet adjuster foot.

Do not adjust tappet with high clearance as will result in noise and insufficient opening of the valves.

- Remove screw driver and both special tools after adjustment is complete.

Tappet Clearance Cylinder Head RH

NOTE

- Ensure "R" mark on camshaft is aligned to cylinder head.

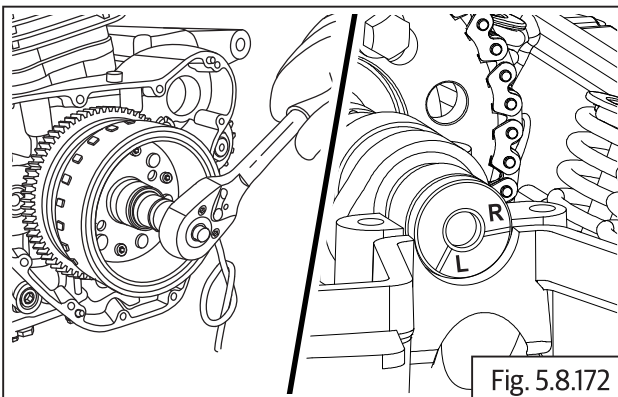

Fig. 5.8.172

- Ensure the **angular edge** of the special tool (**a**) is correctly located in the slot on the camshaft on RH side and the tool is resting correctly on the cylinder head.

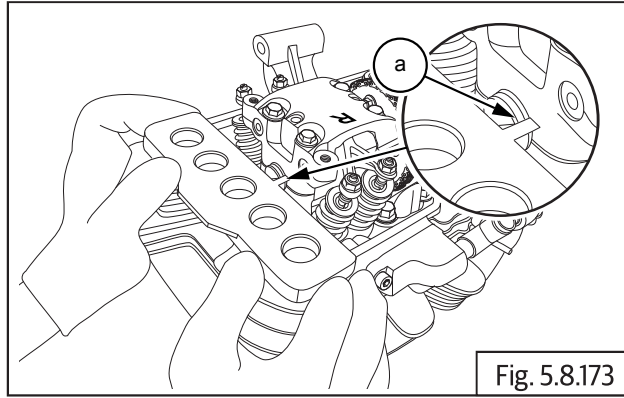

Fig. 5.8.173

SPL

Part No: ST-27546-1

Part Name: Cam - TDC Aligning Plate

- Adjust the RH tappets clearances as mentioned in tappets adjustment LH.

5.8.34. Cover Cylinder Head

NOTE

- Ensure the cover-cylinder head seating surface and gasket seating groove are clean.
- Locate new rubber gasket in the groove in cylinder head and ensure it is properly and evenly seated .

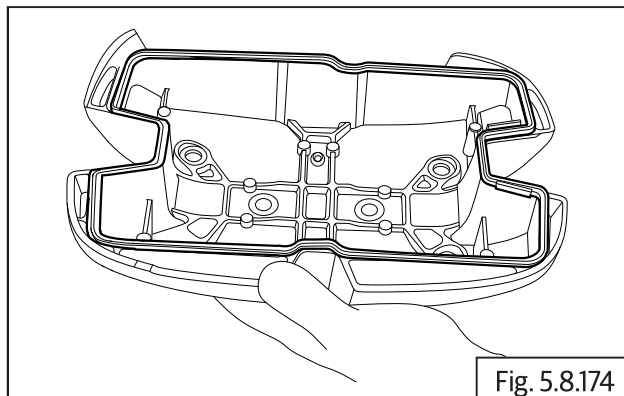

Fig. 5.8.174

- Locate cylinder head cover (**a**) on cylinder head with its narrow deep slot facing towards front of the engine.