

WORKSHOP
MAINTENANCE MANUAL
FOR THE

Royal Enfield

350 BULLET
and
500 BULLET



WORKSHOP MANUAL BULLET

INDEX

	Page Nos.
PREFACE, PRECAUTIONS & GENERAL INSTRUCTIONS	- 2
ROUTINE MAINTENANCE	- 3-5
TECHNICAL SPECIFICATIONS 350cc & 500cc	- 6-9
DESCRIPTION OF ENGINE PARTS	- 10-13
DECARBONISING	- 14-18
SERVICE OPERATION - ENGINE ON FRAME	- 19-28
SERVICE OPERATION – ENGINE – REMOVED FROM FRAME	- 29-32
GEAR BOX (4 SPEED)	- 33-37
LUBRICATION SYSTEM	- 38-40
FRAME REAR SUSPENSION	- 41-42
FRONT FORK (HYDRAULIC)	- 43-46
WHEELS	- 47-55
ADJUSTMENT OF BRAKES	- 56-57
TYRES - REMOVAL AND REPLACEMENT	- 58-60
IGNITION AND LIGHTING SYSTEM	- 61-71
WIRING DIAGRAMS	- 69-71
ELECTRICAL CONNECTION DETAILS	- 72-74
CARBURETTOR	- 75-78
SERVICE LIMITS	- 79
TROUBLE SHOOTING	- 80-99
TORQUE VALUE CHART	- 100
SPECIAL TOOLS	- 101-106
METRIC CONVERSION TABLE	- 107
ELECTRIC START SUPPLEMENT	- 109-118
5 SPEED GEARBOX SUPPLEMENT	- 119-122

WORKSHOP MANUAL BULLET

PREFACE

We take pleasure in releasing this Maintenance Manual as a guide to good service. Most of the servicing can be well done by the average owner. Numerous diagrammatic sketches and photo illustrations have been introduced for better understanding. However for an owner who feels uncertain of his ability to, undertake any stripping and re-building for a major overhaul, we strongly recommend that the work be done by an authorised 'ENFIELD DEALER/DISTRIBUTOR'. Needless to mention that the use of proper service maintenance tools and genuine Enfield spares will ensure best results.

Whilst every care is taken to ensure that the information in this manual is correct, no liability can be accepted by Royal Enfield or the publisher for loss, damage or injury caused due to errors or omissions in the information given.

PRECAUTIONS AND GENERAL INSTRUCTIONS

Observe the following points without fail, when dismantling and reassembling Motorcycle parts.

- Be sure to replace packings, gaskets, circlips, 'O' rings and cotter pins with new ones, for 'safe riding'.
- Tighten bolts & nuts starting from the larger diameter ones to the smaller diameter and from inside to outside diagonally, with specified tightening torque
- Always use genuine spares and recommended grade of oils only
- When using a torque wrench for checking, always loosen the bolt or nut by half turn and then tighten to the specified torque. Never use torque wrench for loosening a bolt or nut.

BUYING SPARE PARTS

When ordering spare parts for your Motorcycle it is advisable to deal direct with the Enfield official dealer/distributor, who should be able to supply most of the parts ex-stock.

Always quote the Engine Number and Frame Number and description of part required. It is advisable to indicate the colour scheme especially while ordering parts for frame, side panels, tank, mudguards, etc.

ALWAYS USE GENUINE "ENFIELD" SPARES

WORKSHOP MANUAL BULLET

ROUTINE MAINTENANCE

Introduction

Periodic routine maintenance is a continuous process that commences immediately after the machine is used. It must be carried out at specified mileage recordings, or a calendar basis if the machine is not used frequently.

Maintenance should be regarded as an insurance policy, to keep the machine in peak condition and to ensure long, trouble free service.

The various maintenance tasks are described under their respective mileage and period. The intervals between the various maintenance tasks serves only as a guide, as the machine gets older or used under particularly adverse conditions, it would be advisable to reduce the period between each check.

For ease of reference each service operation is described in detail under the relevant heading. In order to carryout the routine maintenance tasks, a good selection of general workshop tools is absolutely essential.

Included in the kit must be a range of metric ring or combination spanners, a selection of phillips head screw drivers and pair of circlip pliers.

No special tools are required for the normal routine maintenance tasks. The tools contained in the tool kit supplied with every new machine will prove adequate for each task, or if they are not available, the tools found in the average household will usually suffice.

WORKSHOP MANUAL BULLET

Daily

A daily check of the Motorcycle is essential both from mechanical and safety aspects. It is a good idea to develop this checking procedure in a specific sequence so that it will ultimately become as instinctive as actually riding the machine. Done properly, this simple checking sequence will give advanced warning of impending mechanical failures and conditions which may jeopardize the safety of the rider.

- Clean the motorcycle with a clean cloth.
- Check engine oil level, using the dipstick provided in the oil tank cap: Maintain oil level upto 'H' mark. If necessary top up oil to the required level.
- Check proper operations of all controls viz. clutch, accelerator, brakes, all lights and horns.
- Check tyre pressure, with a pressure gauge. Check tyre pressure when the tyres are cold. It is worth purchasing a small pocket pressure gauge which can be relied upon, to give consistent readings than garage forecourt gauges which tend to be less dependable.
- Tyre Pressure Front: 32 PSI - Rear: 36 PSI.
- Check tyres for foreign materials and remove them to prevent possible punctures.
- Check for adequate fuel in the petrol tank, for the journey planned.
- Check for proper charging of the battery after starting the machine.

Monthly - 300 Miles/500 Kms

- Check oil levels - engine & clutch
-
- Check contact breaker gap and adjust if necessary
-
- Check and adjust tappet clearance if necessary
-
- Check clutch, throttle and front brake cables and adjust if excessive play noticed
-
- Lubricate rear chain
-
- Adjust front & rear brakes
-
- Check wheel rims, for excessive runout, breakage of spokes and tyres for cracks or cuts.
-
- Check condition of battery and electrolyte level, and top up with distilled water up to the level provided.

WORKSHOP MANUAL BULLET

Tri monthly – 3000 miles/5000 kms

- Clean, and adjust plug gap or replace spark plug.
- Check and service contact breaker points.
- Check and adjust ignition timing.
- Check and adjust valve tappet clearance.
- Clean airfilter.
- Clean, tune up carburettor.
- Clean fuel tap gauze.
- Clean fuel tank and fuel lines.
- Check and adjust clutch.
- Adjust front & rear brakes
- Check front fork oil level.
- Check all electrical connections and functions of head light, trafficator, horn, speedometer, etc.

Six monthly – 6000 miles/10,000 kms

Carry out all the operations mentioned for Tri monthly service and check the following:

- Change oil-engine & clutch.
- Clean or replace oil filter
- Change front fork oil
- Check front & rear brake linings and replace if necessary
- Check for play in steering head bearings and adjust
- Check operation of steering lock and lubricate if necessary
- Check operation of side stand and condition of spring.

WORKSHOP MANUAL BULLET

TECHNICAL SPECIFICATIONS - BULLET - 350 CC

Engine

Single Cylinder 4 Stroke with Overhead Valves

Cubic Capacity	-	-	-	346 CC
Stroke	-	-	-	90 mm.
Bore-Nominal	-	-	-	70 mm
Actual	-	-	-	69.875mm or 2.751 in.
Compression Ratio	-	-	-	7.25: 1
Compression Pressure	-	-	-	110 ± 5 PSI (recommended)
Engine output	-	-	-	18 BHP / 5625 RPM
Torque	-	-	-	2.74 kgm/2875 RPM

Piston and piston rings:

Ring clearance in grooves	-	-	-	(Dimensions for new components)
Plain (2)	-	-	-	.001/.003"
Scraper	-	-	-	.002/.004"
Ring end gap in bore	-	-	-	.015/.020"
Maximum ring gap permissible	-	-	-	0.030"
Gudgeon pin diameter	-	-	-	.7498/.7500"
Crank pin diameter	-	-	-	1.24875/1.249"
Connecting rod small end diameter	-	-	-	.7505/.7507"

Crankshaft:

Driving side Ball bearing	-	-	-	25 x 62 x 17 mm (6305)
Roller bearing	-	-	-	25 x 62 x 17 mm (NU 305 or N 305)
Timing side Roller bearing	-	-	-	25 x 52 x 15 mm (NU205 or N 205R)
Cam lift	-	-	-	.3125 in.
Valve lift	-	-	-	.3125 in.

Valve timing with .012" clearance

Exhaust opens	-	-	-	75° BBDC
Exhaust closes	-	-	-	35° ATDC
Inlet opens	-	-	-	30° BTDC
Inlet closes	-	-	-	60° ABDC
Rocker bearing inside diameter	-	-	-	.625/.626" (Dimensions for new Components)
Rocker spindle diameter	-	-	-	.6235/.624"
Inlet valve stem diameter	-	-	-	.3425/.3430"
Exhaust valve stem diameter	-	-	-	.3405/.3410"
Valve guide internal diameter	-	-	-	.3437/.3447"
Valve guide external diameter	-	-	-	.6270/.6275"
Tappet guide internal diameter	-	-	-	.3752/.3760"
Tappet guide external diameter	-	-	-	.7505/.7510"

Lubrication - - - - Dry sump, Oil tank integral with crank case

Clutch - - - - Wet multiplate, oil immersed

Engine sprocket - - - - 25 teeth

Clutch Sprocket - - - - 56 teeth

Primary drive chain - - - - 3/8" pitch Duplex chain.

WORKSHOP MANUAL BULLET

GearBox:

Overall gear ratios - - - 5.32, 7.26, 9.80, & 14.80

Mainshaft ball bearings - - - Small - 6303
Large - 6206

Final drive sprocket - - - 16 teeth

Rear drive chain - - - 5/8" x 94 pitch chain

Brake drum sprocket - - - 38 teeth

Carburettor - - - Mikcarb-VM-24

Main jet - - - 90

Pilot jet - - - 25

Contact Breaker (Coil ignition):

Points gap - - - 0.14/0.16" (0.35 to 0.4mm)

Timing before T.D.C.- - - 1/32" (0.8 mm) retarded

Spark plug - - - 14 mm. diameter B7HS (NGK) or equivalent

Spark plug gap - - - 0.46 to 0.50mm

Condenser (Capacitor) - - - 0.18 to 0.25 M.F.D.

Suspension:

Front - - - Telescopic, hydraulic damping

Stroke - - - 155mm

Rear - - - Pivoted fork with shock absorbers

Wheel Rim Type - - - WM 2- 19

Tyre Size - - - 3.25 x 19 (Front)

3.50 x 19 (Rear)

Wheel Bearings

(Front & Rear) - - - 17 x 40 x 12 mm (6203) or 6203 ZZ

Brakes - - - Mechanical, internally expanding shoe type

Front - - - 178 mm x 38 mm Twin leading shoes

Rear - - - 153 mm x 25 mm Single Leading Shoe

Fuel tank:

Full Tank Capacity - - - 14.5 litres

Reserve Capacity - - - 1.25 litres

Oil Capacity & Grade:

Oil Tank - - - 2.25 litres, SAE 20W50

Fork - - - 200 ml. on each leg. Hydraulic oil or SAE 10W30

Clutch - - - 420 ml. approximately SAE 20W40

Gear box - - - 700 grams of veedol '00' grease (for topping up use SAE 20W50)

Dimensions:

Weight (Dry) - - - 163Kg.

Pay load (Max) - - - 172Kg.

Ground clearance - - - 14 cm. (140mm)

Overall length - - - 212 cm (2120mm)

Overall width - - - 75 cm (750mm)

Saddle Height - - - 85 cm. (850mm)

Wheel base - - - 137 cm (1370mm)

Electricals:

System - - - 12VDC

WORKSHOP MANUAL BULLET

TECHNICAL SPECIFICATIONS - BULLET - 500 CC

Engine

Single Cylinder 4 Stroke with overhead Valves

Cubic Capacity	-	-	-	499 CC
Stroke	-	-	-	90 mm
Bore-Nominal	-	-	-	84 mm
Actual	-	-	-	83.96/83.97 mm
Compression Ratio	-	-	-	6.5:1
Compression Pressure	-	-	-	110 ± 5 PSI (Recommended)
Engine output	-	-	-	22 BHP/5400 RPM
Torque	-	-	-	3.5 Kgm/3000 RPM

Piston and piston rings

Ring clearance in grooves				(Dimensions for new components)
Plain(2)	-	-	-	.001/.003"
Scraper	-	-	-	.002/.004"
Ring end gap in bore	-	-	-	.015/.020"
Maximum ring gap permissible	-	-	-	0.039"
Gudgeon pin diameter	-	-	-	.7498/.7500"
Crank pin diameter	-	-	-	1.24875/1.249"
Connecting rod small end diameter	-	-	-	.7505/.7507"

Crankshaft

Driving side Ball bearing	-	-	-	25 x 62 x 17 mm (6305)
Roller bearing	-	-	-	25 x 62 x 17 mm (NU 305 or N 305)
Timing side Roller bearing	-	-	-	25 x 52 x 15 mm (NU 205 or N 205R)
Cam lift	-	-	-	.3125 in
Valve lift	-	-	-	.3125 in.

Valve timing with .012" clearance

Exhaust opens	-	-	-	75° BBDC
Exhaust closes	-	-	-	35° ATDC
Inlet opens	-	-	-	30° BTDC
Inlet closes	-	-	-	60° ABDC
Rocker bearing inside diameter	-	-	-	.625/.626" (Dimensions for new Component)
Rocker spindle diameter	-	-	-	.6235/.6240"
Inlet valve stem diameter	-	-	-	.3425/.3430"
Exhaust valve stem diameter	-	-	-	.3405/.3410"
Valve guide internal diameter	-	-	-	.3437/.3447"
Valve guide external diameter	-	-	-	.6270/.6275"
Tappet guide internal diameter	-	-	-	.3752/.3760"
Tappet guide external diameter	-	-	-	.7505/.7510"

Lubrication

Dry sump, Oil tank integral with crank case

Clutch

Wet multiplate. Oil immersed

Engine sprocket	-	-	-	25 teeth
Clutch	-	-	-	56 teeth
Primary drive chain	-	-	-	3/8 pitch Duplex chain.

WORKSHOP MANUAL BULLET

Gear box

Overall gear ratios	-	-	-	5.01, 6.83, 9.22 & 13.93
Bearings	-	-	-	Small - 6303 Large - 6206
Final drive sprocket	-	-	-	17 teeth
Rear drive chain	-	-	-	5/8" x 95 pitch chain
Carburettor	-	-	-	Mikcarb-VM-28
Main jet	-	-	-	110
Pilot jet	-	-	-	25

Contact Breaker (Coil ignition)

Points gap	-	-	-	0.14/0.16" (0.35 to 0.4mm)
Timing before T.D.C	-	-	-	1/32" (0.8 mm) Retarded
Spark plug	-	-	-	NGK BR 8 ES or equivalent
Spark plug gap	-	-	-	0.46 to 0.50mm
Condenser (Capacitor)	-	-	-	0.18 to 0.25 M.F.D

Suspension

Front	-	-	-	Telescopic, Hydraulic damping
Stroke	-	-	-	155 mm
Rear	-	-	-	Pivoted fork with shock absorbers

Wheel Rim Type

WM 2 - 19	-	-	-	WM 2 - 19
Tyre size	-	-	-	3.25 x 19 (Front) 3.50 x 19 (Rear)

Wheel Bearings

(Front & Rear)	-	-	-	17 x 40 x 12mm (6203) or 6203 ZZ
----------------	---	---	---	----------------------------------

Brakes

Front	-	-	-	Mechanical, internally expanding shoe type 178 mm x 38 mm Twin leading shoes
Rear	-	-	-	153 mm x 25 mm Single leading shoe

Fuel tank

Full Tank Capacity	-	-	-	14.5 litres
Reserve capacity	-	-	-	1.25 litres

Oil Capacity & grade

Oil tank	-	-	-	2.25 litres, SAE-20W50
Fork	-	-	-	200 ml. on each leg. Hydraulic Oil or SAE 10W30
Clutch	-	-	-	420 ml. approximately SAE-20W40
Gear Box	-	-	-	700 grams of veedol '00' grease (for topping up use SAE 20W50)

Dimensions

Weight (Dry)	-	-	-	168 Kg.
Pay load (Max)	-	-	-	172 Kg.
Ground clearance	-	-	-	14 cm (140mm)
Overall length	-	-	-	212 cm (2120mm)
Overall width	-	-	-	75 cm (750mm)
Saddle Height	-	-	-	85 cm (850mm)
Wheel base	-	-	-	137 cm (1370mm)

Electricals

System	-	-	-	12 V DC
--------	---	---	---	---------

WORKSHOP MANUAL BULLET

ENGINE ASSEMBLY

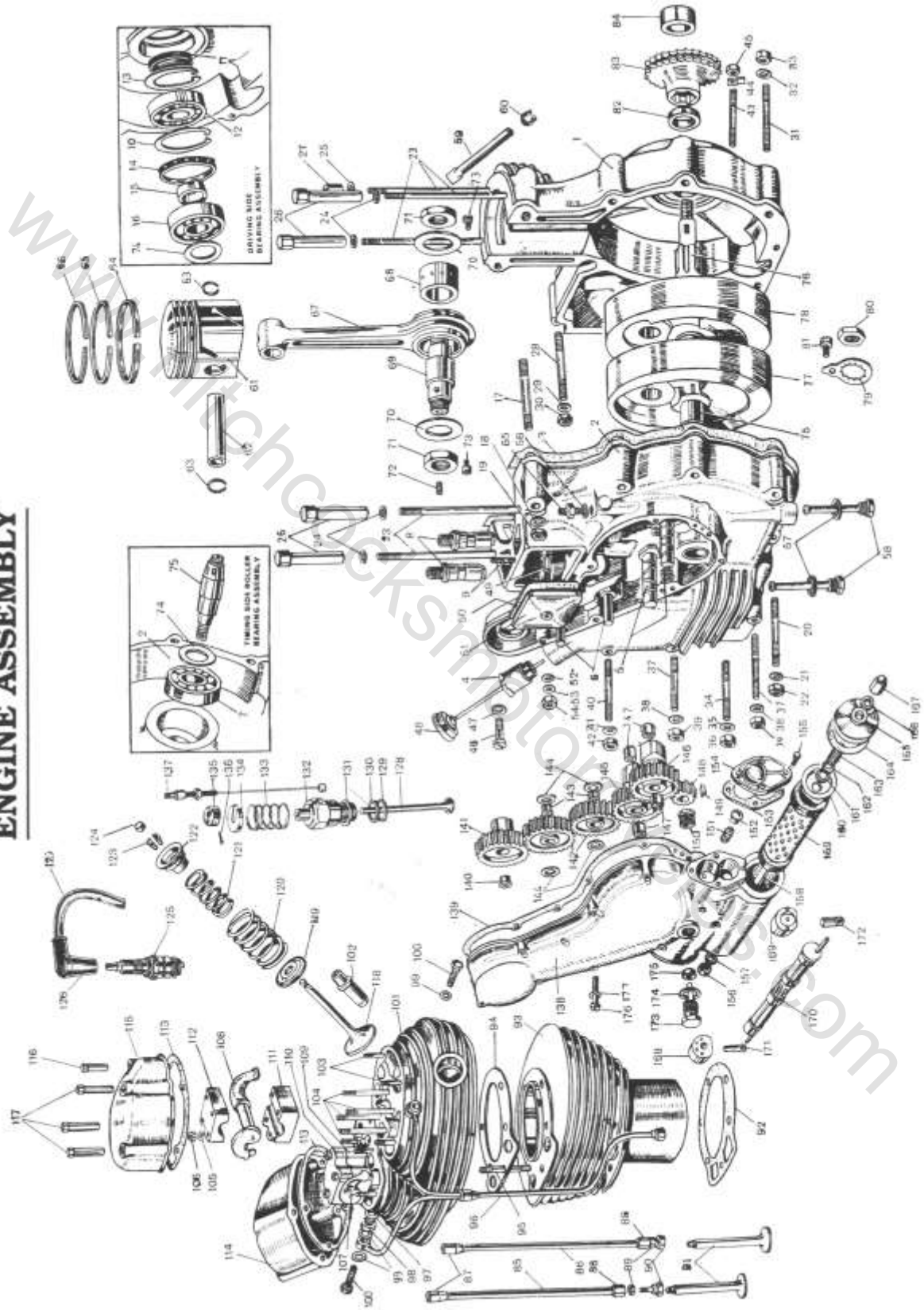

WORKSHOP MANUAL BULLET

ENGINE PARTS

1. Crankcase D/S
2. Crankcase T/S
3. Joint washer
4. Oil filler cap collar
5. Cam spindle
6. Idler pinion spindle
7. Timing shaft roller bearing
8. Tappet guide
9. Cylinder base stud
10. Circlip (Seegar)
11. Oil seal
12. Ball bearing
13. Circlip (Seegar)
14. Distance tube (outer)
15. Distance tube (inner)
16. Roller bearing
17. Stud, Crank Case Neck
18. Washer, Crank Case Neck Stud
19. Nut, Crank Case Neck Stud
20. Stud Crank Case Bottom Joint
21. Washer, Crank Case Bottom Joint
22. Nut, Crank Case Bottom Joint
23. Head & Cylinder stud
24. Washer, Head and Cylinder Stud
25. Washer, Head stud
26. Nut, Head and Cylinder Stud
27. Nut, Head and Cylinder Stud
28. Crank Case Stud, below Distributor
29. Washer, below Distributor
30. Nut, below Distributor
31. Stud -Front engine plates
32. Washer, Front Engine plate
33. Nut Front Engine Plate
34. Rear engine plates
35. Washer, Rear Engine Plate
36. Nut, Rear Engine Plate
37. Stud, Crank Case Rear Joint
38. Washer, Crank Case Rear Joint
39. Nut, Crank Case Rear Joint
40. Stud, Crank Case Rear Joint
41. Washer, Crank Case Rear Joint
42. Nut, Crank Case Rear Joint
43. Stud-Chaincase attachment
44. Oil Seal Retainer
45. Nut, Oil Seal Retainer
46. Distributor flange pin
47. Distributor flange pin Washer
48. Oil filler cap
49. Tappet cover stud
50. Washer, Tappet Cover Stud
51. Tappet Cover
52. Washer (Fibre), Tappet Cover Stud
53. Washer (Steel), Tappet Cover Stud
54. Tappet cover nut
55. Oil pipe union
56. Washer, Oil Pipe Union
57. Washer Oil filter gauze
58. Oil feed & return filters
59. Breather pipe
60. Breather pipe clip
61. Piston
62. Gudgeon pin
63. Circlip
64. Piston ring (scraper)
65. Piston ring (compression) lower taper
66. Piston ring (compression) top, chrome
67. Connecting rod
68. Connecting rod floating bush
69. Crank pin
70. Thrust washer
71. Crank pin nut
72. Crank pin oil hole grub screw
73. Crank pin nut keeper screw
74. Thrust washer
75. Timing shaft
76. Driving shaft
77. Fly wheel T/S
78. Fly wheel D/S
79. Lock ring
80. T/S shaft nut
81. Lock ring screw
82. Engine sprocket distance tube
83. Engine sprocket 25T
84. Alternator distance tube

WORKSHOP MANUAL BULLET

BELLET 500 CC ENGINE ASSEMBLY

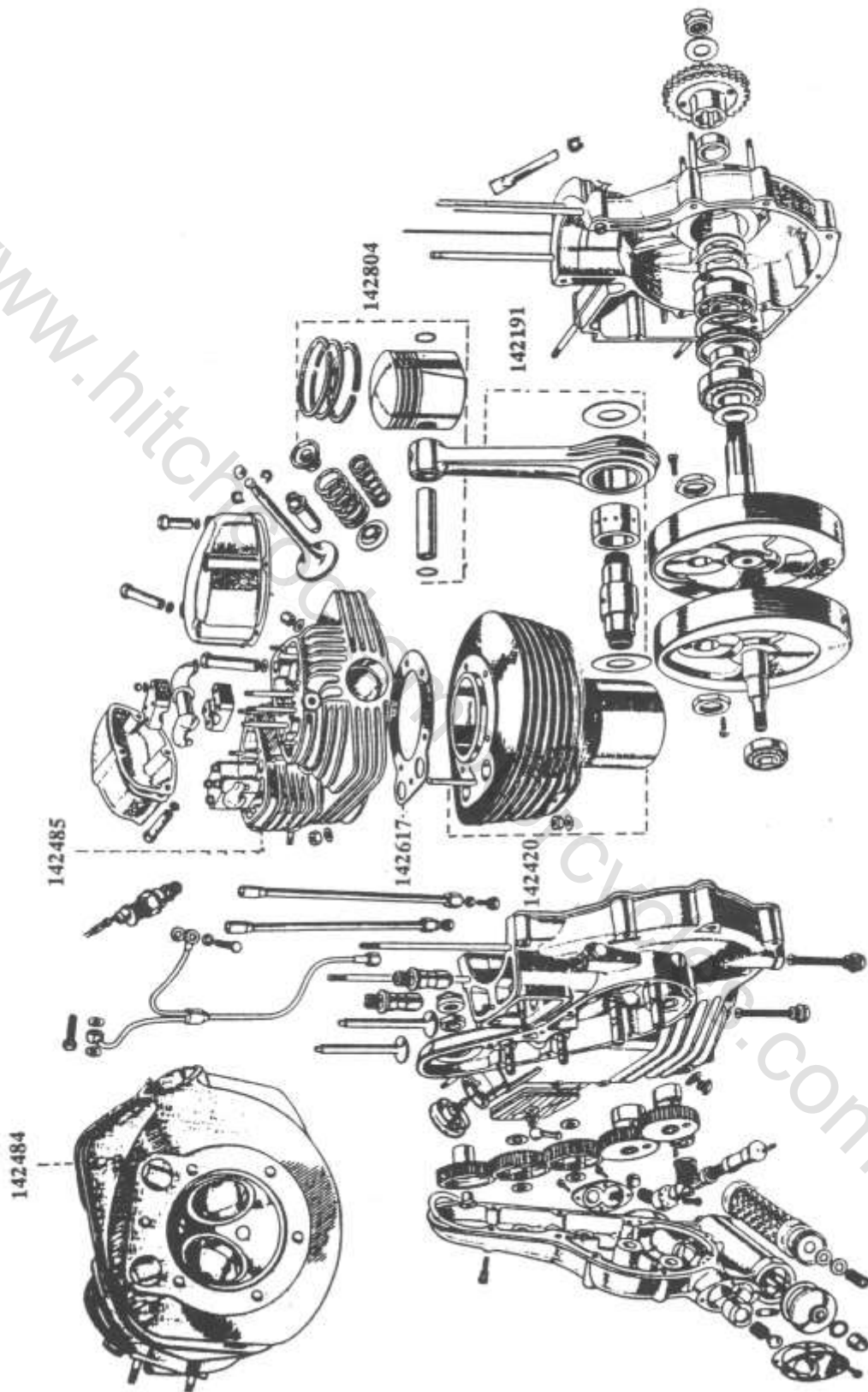

FOR THE PART NOS. SHOWN IN THE FIG. PLEASE REFER PARTS LIST.

WORKSHOP MANUAL BULLET

- | | | |
|---|---|---|
| <u>85. Push rod inlet</u> | <u>116. Nut (short) Rocker Box</u> | <u>147. Cam bush</u> |
| <u>86. Push rod, exhaust</u> | <u>117. Nut (long) Rocker Box</u> | <u>148. Timing pinion 20T</u> |
| <u>87. Push rod end, top</u> | <u>118. Valve</u> | <u>149. Key</u> |
| <u>88. Push rod end, bottom</u> | <u>119. Valve spring collar, bottom</u> | <u>150. Oil pump worm</u> |
| <u>89. Push rod cup lock nut</u> | <u>120. Valve spring, outer</u> | <u>151. Oil pump disc spring</u> |
| <u>90. Push rod cup</u> | <u>121. Valve spring, Inner</u> | <u>152. Spring end pad</u> |
| <u>91. Tappet</u> | <u>122. Valve spring collar, top</u> | <u>153. Gasket Oil Pump Cover</u> |
| <u>92. Cylinder barrel joint washer</u> | <u>123. Valve split collar</u> | <u>154. Oil pump cover</u> |
| <u>93. Cylinder barrel</u> | <u>124. Valve stem cap</u> | <u>155. Oil pump cover screw</u> |
| <u>94. Cylinder head joint washer</u> | <u>125. Sparkplug</u> | <u>156. Nut, Oil Cleaner Stud</u> |
| <u>95. Stud, Cylinder Base</u> | <u>126. Sparkplug cap</u> | <u>151. Washer, Oil Cleaner Stud</u> |
| <u>96. Rocker oil pipe complete</u> | <u>127. H.T. Lead</u> | <u>158. Stud, Oil Cleaner</u> |
| <u>91. Rocker Oil Union Bush Washer</u> | <u>128. Decompressor valve</u> | <u>159. Oil cleaner element</u> |
| <u>98. Oil union bush</u> | <u>129. Washer, Decompressor body</u> | <u>160. Oil cleaner spring cap</u> |
| <u>99. Washer Oil Pipe banjo Union</u> | <u>130. Washer, Decompressor body</u> | <u>161. Felt washer</u> |
| <u>100. Oil pipe banjo</u> | <u>131. Washer (Plain), Decompressor body</u> | <u>162. Thrust washer</u> |
| <u>101. Cylinder head</u> | <u>132. Decompressor body</u> | <u>163. Oil cleaner spring</u> |
| <u>102. Valve guide</u> | <u>133. Spring, Decompressor</u> | <u>164. Washer, Oil Cleaner Cap</u> |
| <u>103. Stud, Rocker Box</u> | <u>134. Spring Cap, Decompressor</u> | <u>165. Oil cleaner cap</u> |
| <u>104. Stud, Rocker Bearing</u> | <u>135. Cable block</u> | <u>166. Washer, Oil Cleaner Cap Nut</u> |
| <u>105. Washer, Rocker Bearing</u> | <u>136. Cable block split pin</u> | <u>167. Nut, Oil Cleaner Cap</u> |
| <u>106. Nut, Rocker Bearing</u> | <u>137. Decompressor cable assembly</u> | <u>168. Oil pump disc (feed)</u> |
| <u>101. Rocker, Inlet</u> | <u>138. Timing cover</u> | <u>169. Oil pump disc (return)</u> |
| <u>108. Rocker, exhaust</u> | <u>139. Timing cover joint washer</u> | <u>170. Oil pump spindle</u> |
| <u>109. Rocker bearing inlet</u> | <u>140. Distributor pinion nut</u> | <u>171. Plunger (feed)</u> |
| <u>110. Rocker bearing cap Inlet</u> | <u>141. Distributor pinion 40T</u> | <u>172. Plunger (return)</u> |
| <u>111. Rocker bearing, exhaust</u> | <u>142. Idler pinion 40T</u> | <u>173. Oil feed plug</u> |
| <u>112. Rocker bearing cap, exhaust</u> | <u>143. Idler pinion bush</u> | <u>174. Washer</u> |
| <u>113. Gasket</u> | <u>144. Idler pinion thrust washer</u> | <u>175. Cork oil retainer</u> |
| <u>114. Rocker box, inlet</u> | <u>145. Cam, inlet</u> | <u>176. Timing cover screw</u> |
| <u>115. Rocker box, exhaust</u> | <u>146. Cam, exhaust</u> | <u>177. Spring Washer, Timing Cover Screw</u> |

WORKSHOP MANUAL BULLET

ENGINE

Decarbonising:

After a few thousands of Kms. of run the carbon build up in the engine will cause general falling off in power, accompanied by increased fuel consumption and starting trouble. Decarbonising will normally be necessary approximately every 8,000 Kms. and this can be carried out without removing the engine from the frame. The mileage between decarbonising will vary from machine to machine depending upon the type of usage. A machine used for frequent short journeys will need more attention than one which is used for fast long distance touring.

1. Removal of the petrol tank

Close the petrol tap. Disconnect the fuel hose from petrol tap end.

Remove the two studs which hold the petrol tank to the frame and pull the tank upwards.

2. Removal of the Cylinder head

Remove the engine steady eye bolt.

Disconnect the high-tension lead from the spark plug. Remove rocker oil pipe.

Remove the exhaust pipe and silencer.

Remove the air filter by undoing the bolts on the sides of the air filter body.

Push the carburettor back clear of the studs after removing the fixing nuts.

Remove the rocker box covers.

Remove the decompressor cable from the lever end of the handle bar (LH side)

Crank the engine until both valves are closed. (Keep in Compression stroke).

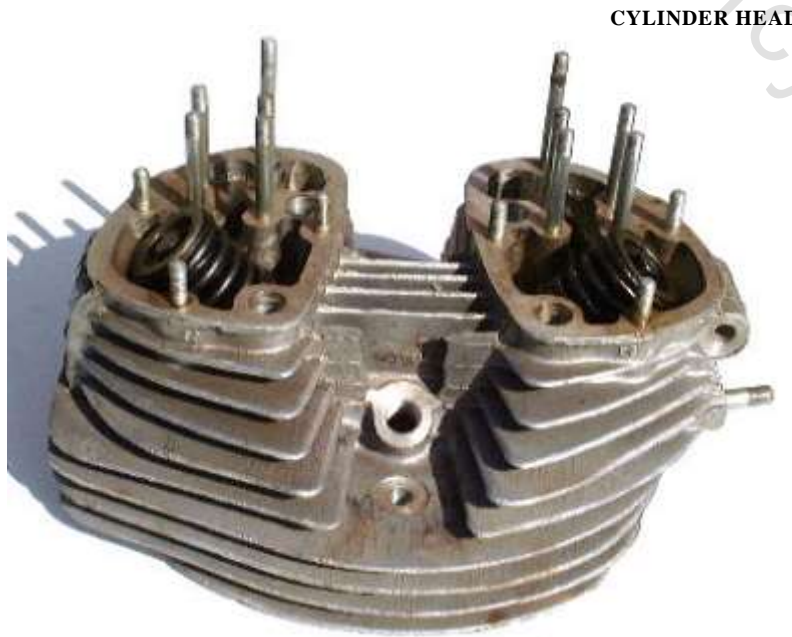

Remove the rocker arms and bearings completely after removing the four 3/16" nuts on each.

Lift out the pushrods both inlet & exhaust.

Remove the six cylinder head nuts & washers.

Lift the cylinder head off the barrel, tapping it gently beneath the exhaust and inlet ports with a wooden mallet. Do not tap the fins.

WORKSHOP MANUAL BULLET

3. Removal of Cylinder and Piston

Slacken the two clamp nuts on top of the crankcase neck.

Remove the 1/4" nut above the tappet chest and lift the barrel

Remove the circlip retaining the gudgeon pin on the timing side of piston taking care not to drop the circlip into the crankcase.

Extract the gudgeon pin using special Tool 2015 (with adaptor if necessary), so that the pin and the piston may be replaced the same way round, i.e., split skirt to the front.

During this operation put a piece of clean rag in the top of the crankcase to prevent foreign matter getting in. Finally cover the crankcase with a clean cloth to prevent ingress of dust and dirt.

REMOVAL OF PISTON

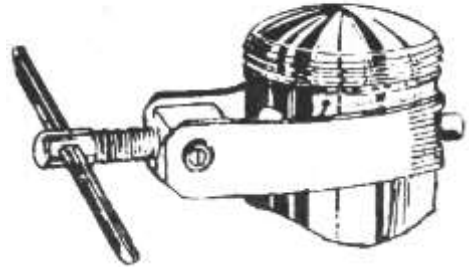

VALVE SPRING COMPRESSOR



4. Removal of Valves

To remove the valves from the cylinder head, first lift off the end caps from the valve stems. If this has stuck, it can be removed by a screwdriver. Using compressing tool 2018 compress the valve springs and remove the split collars from the valve tip. Slacken back the compressing tools and release the springs.

Withdraw the valve and place its springs, top spring collar, bottom collar, the end cap and split conical collars together in order that they may be reassembled with the valve from which they were removed.

If the valve will not slide easily through the valve guide, remove any slight burrs on the end of the valve stem with a carborundum stone or by using a fine Jeweler's file to remove any sharp edge or burr. If the burrs are not removed and the valve is forced out, the valve guide may be damaged.

WORKSHOP MANUAL BULLET

5. Decarbonising the Cylinder head - Combustion Chamber

Remove carbon from the valves, ports and combustion chamber by scraping. Take care not to cause any damage to the valve faces or valve seat inserts. Scrape gently to avoid scoring the cylinder head.

DO NOT, under any circumstance, use caustic soda or potash for the removal of carbon from aluminium alloy.

Remove the piston rings carefully. For cleaning the groove in the piston, a piece of broken piston ring thrust into a wooden handle and filed to a chisel point can be used:

CYLINDER HEAD



6. Piston and Rings

If the piston rings are in good condition they can be put back, taking care to fit them in their original grooves and the same way up. If the rings show brown or black patches or if their gaps, are more than specified service limits (Page 79), when in position in the barrel, new rings should be fitted. The correct gap for new rings is given in the technical specifications (page 6 & 8) for 350 and 500cc. The gap should be measured in the least worn part of the cylinder which will be found at the top or bottom of the bore.

Only For 350cc:

The original size of the cylinder bore is 2.751" (69.875mm). If the wear at any point in the bore exceeds .008" the cylinder should be rebored to .020" and an oversize piston fitted. (It should be rebored to .040" after a further .008" wear). Piston sizes available are .020" and .040" oversize.

The original side clearance between the piston rings and grooves is .003". If the grooves show a wear of .005" the piston should be replaced.

7. Big end bearing inspection

Examine the condition of the big end while the piston is removed. About .010" - .020" end float is permissible and it will be possible to rock the connecting rod slightly. The big end has a floating bush with an original clearance of approximately 003". However, if a DEFINITE up and down play can be felt, engine should be stripped further to have the big end renewed.

CRANKSHAFT BIG END BEARING

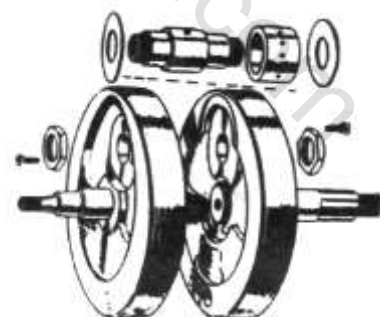

WORKSHOP MANUAL BULLET

8. Valves, Valve Guides and springs

VALVE & SPRING ASSEMBLY

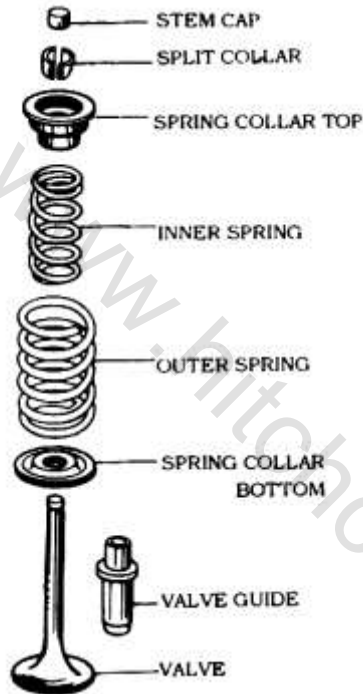

Wear on the valve stems can be seen on examination and if a definite step has formed, the valves should be renewed. Before replacing the valves, they must be ground on to their seats, if good faces are not formed with a reasonable amount of grinding, the seats must be cut with a cutter (included angle 90°) and the valve refaced in a universal grinder. Do not attempt to form good seats by an excessive amount of grinding. This will cause pocketing and restrict the flow of gases. If a pocket has already been formed this must be removed by cutting with a valve seat cutter larger in diameter than the valve head.

Test the valve guides for wear by trying the fit of a new valve in them. Both valves should be quite free, but the exhaust valve has more clearance (.002") than inlet valve.

To remove the valve guides from the head, two special tools are required which can be easily made. The first is a piece of tube with an internal bore of not less than $7/8$ ". The second is a mandrel about 4" long made from $9/16$ " diameter bar with the end turned down to $1/3$ " diameter for a length of $1/2$ ". Support the cylinder head on the tube which fits over the collar of the valve guide. Using the mandrel, force the guide out of the head with a hand press or by using a hammer.

DECOMPRESSOR ASSEMBLY

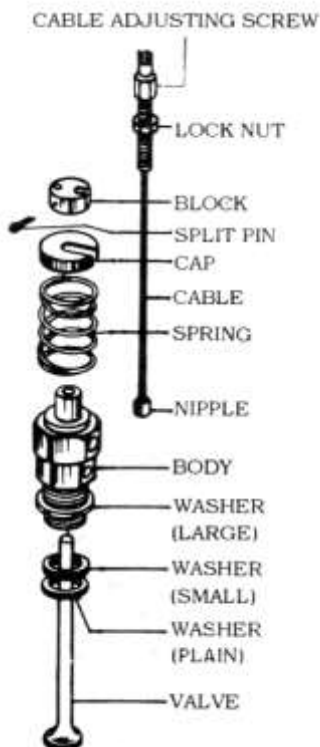

To fit a new guide, support the head at the correct angle and use a hand press and the same mandrel. If a hand press is not available, the guide can be replaced using a hammer and a mandrel, to prevent damage to the guide.

Check the length of the valve springs which are originally 2.020" and 2.095" for the inner and outer springs respectively. If these have reached the specified service limits, they should be renewed.

9. Decompressor

If the decompressor holds compression and operates freely, there is no need to interfere with it except to remove the carbon from the head of the valve. If the valve is leaking, it will be necessary to regrind it on its seat. This can be done without completely dismantling it. Having disconnected the control cable from the handle bar, unscrew the decompressor from the cylinder head. Compress the spring and remove the spring cap. Unscrew the adjusting screw and locknut from the cable block and pull the cable sideways out of the block. Push the spring

WORKSHOP MANUAL BULLET

upwards and pull the cable nipple out of the body, it will now be possible to remove the cable and nipple through the spring, leaving the decompressor body and spring detached from the control cable.

The spring and the cap should now be replaced. The valve may be ground in by applying a thin coating of grinding paste on the seat of the valve and twisting it to and fro by means of the cable block at its upper end and occasionally lifting the valve from its seat. Do not rotate the valve through a complete revolution before lifting, as this will groove the seat. After grinding, wash the whole assembly thoroughly in petrol, opening and shutting the valve while doing so. Make sure that all traces of grinding paste have been removed. If the paste should get into the cylinder serious damage would be caused.

If the valve shows a tendency to stick-up in the body but otherwise is satisfactory, this can be cured by washing in petrol, though in this case it will not be necessary to disconnect the control cable; if the decompressor valve is badly burnt or bent it must be replaced.

10. Re-assembly after Decarbonising

Before building up the engine, see that all parts are scrupulously clean and place them on a clean tray, work bench or over a clean sheet of paper. While re-assembling it is advisable to fit a new gasket between the cylinder barrel and the crankcase.

Smear clean oil over the piston and space the ring gaps. The second ring is a taper ring and is marked TOP on the upper surface.

WARNING: This mark should be on top when fitted. Reversing the ring will result in pumping of oil into the cylinder and consequent smoking.

Place the piston over the connecting rod small end ensuring the split skirt is facing the front and insert the gudgeon pin. Secure the gudgeon pin with the circlips. Oil the cylinder bore and gently push barrel over the piston while keeping the rings compressed in their grooves and seat it gently on the barrel gasket. Refit the 1/4" nut above the timing chest.

When fitting the head again, apply jointing compound sparingly on both sides of the gasket. Replace the six nuts and tighten them progressively and diagonally from one side to the other to prevent distortion.

WARNING: Excess compound may block oilways.

Place the push rods with the adjustable parts downwards. The shorter pushrod is the inlet. Ensure valve stem caps are fixed on the valve stems. Position the rockers and bearings, making sure that the oil feed holes are at the bottom and that the caps and bases are in line when tightened down. Adjust the push rods after ensuring piston is in 'TDC' on compression stroke. The silencer could be cleaned of carbon using a hot caustic soda solution, if necessary.

NOTE: The cylinder head and base nuts should be checked again for tightness, after the engine has been run long enough to get it thoroughly warm. Tighten the clamp nuts on crankcase finally. For torque tightening of cylinder head nuts please refer torque chart on Page No. 100

CYLINDER HEAD 500 CC



CYLINDER HEAD 350CC



WORKSHOP MANUAL BULLET

SERVICE OPERATION - WITH ENGINE IN FRAME

1. Removal of the Timing cover

First place a tray under the engine to hold the oil which will escape when the cover is removed.

Remove the exhaust pipe and silencer. Remove ten screws from the timing cover, taking care not to lose the sealing washers, one for each screw.

NOTE: When removing or refitting the timing cover it is important that the engine is gently cranked. This will prevent damage of the pump worm or the pump spindle.

Draw off the timing cover, tapping it lightly if necessary with a wooden mallet.

While refitting the timing cover ensure that the joint washer is correctly located over the oil holes, using a little grease (not compound) to hold it in position.

Ensure that the cork plug is in position in the hole in the pump worm. If the plug is damaged it should be renewed to ensure oil flow to the big end bearing.

NOTE: The filter chamber should be filled with clean oil before the timing cover is refitted.

Ensure proper functioning of oil pump by checking oil flow at rocker pipe union when the engine is running at slow speed. Slacken the oil pipe banjo union to see the oil flow and clamp it again properly. Wipe the oil that has oozed out.

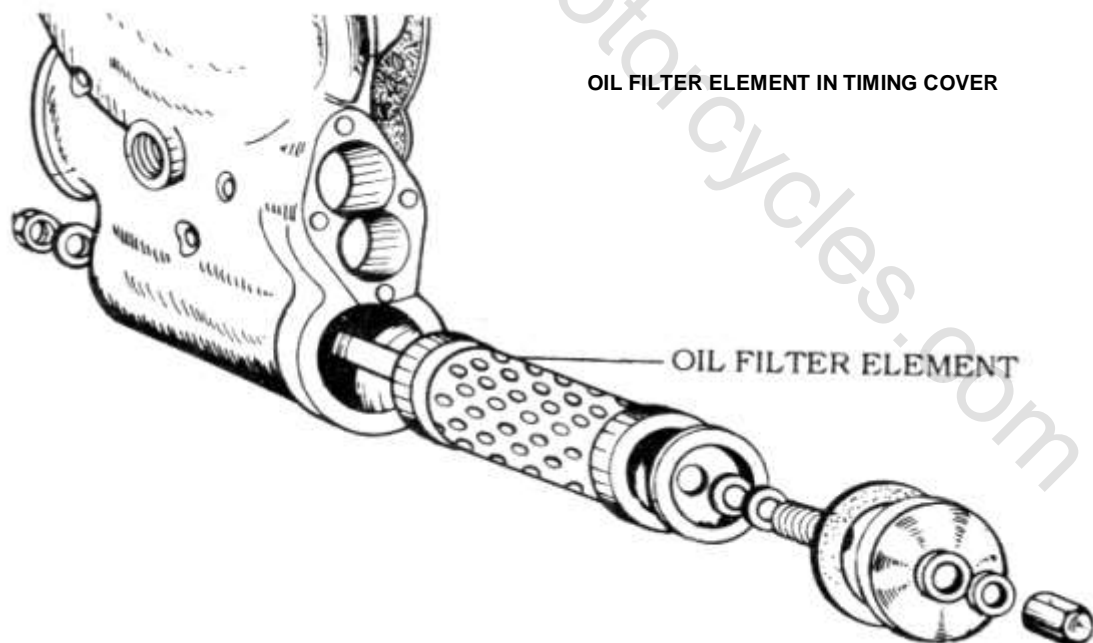

WORKSHOP MANUAL BULLET

2. Cleaning/Replacement of Oil Filter Element - Oil Feed and Return Filters

The oil filter is located in the timing cover immediately below the oil pumps. The felt element should be taken out and washed in petrol after the first 800 Kms. and subsequently, every 4,000 Kms. Fit a new element every 8,000 Kms.

The filter element can be removed by unscrewing the nut holding the end cap in position. When re-assembling the filter take care that no grit or other foreign matter is sticking to it. After replacing the filter element it is essential to run the engine at idling for about five minutes to ensure that oil reaches the big end. If the timing cover has been removed, fill the filter chamber with clean oil before replacing the cover.

The feed and return filters are fixed on the drain plugs in oil sump and crank case. These can be cleaned by rinsing in a solvent and during reassembly ensure the filters are not twisted.

3. Overhauling of Oil feed and return Pumps

- Remove the timing cover.
- Remove the end covers from both pumps.
- Remove the pump discs and plungers.
- Remove the pump spindle which can be pulled out only from the front or return pump end.
- Check the fit of the plungers in the pump discs which should be sliding fit and should be able to be moved in and out by hand.

Arrangement of oil filter

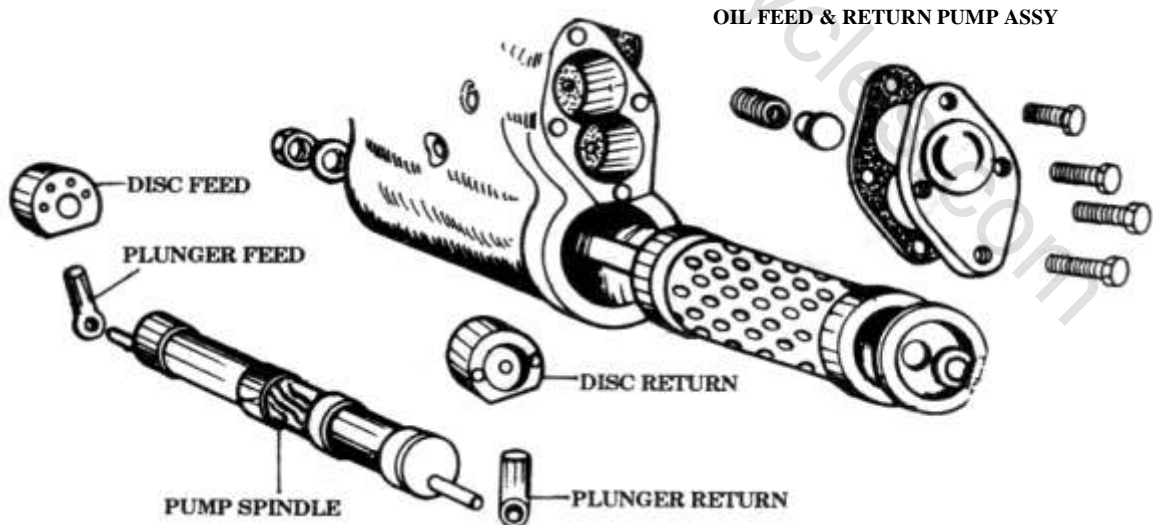
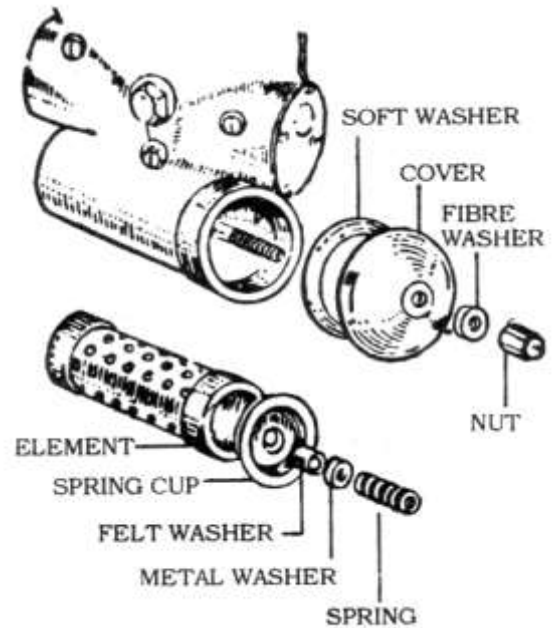

WORKSHOP MANUAL BULLET

When matching a plunger in the pump disc, if it is found to be too tight a fit, carefully lap the plunger in the pump disc. Using metal polish until it is just free.

If the pump disc is not seating properly in the timing cover or if a new pump disc is fitted, it should be ensured that the pump disc matches properly and has a perfect seating in the timing cover.

Lap the discs in the timing cover with fine metal lapping paste or liquid metal polish using special tools 2034 for feed pump disc and 2035 for return pump disc, until a fine, grey surface is obtained on the pump disc face.

NOTE: Replacement pump discs have a lip left at the opposite side of the lapped face. The purpose of this is to hold the disc, central in the housing during lapping-in. It should be filed off before the pump is finally assembled. Care should be taken not to damage the lapped face.

Wash all components and passages, thoroughly with petrol, after lapping, to remove all traces of grinding paste. Check the pump disc springs for fatigue by assembling in the timing cover and placing the pump covers in position. The latter should be held 1/8" off the timing cover if the springs are correct. The pump spindle should be renewed if excessive wear has taken place on the teeth.

Reassemble the oil pumps, replacing the cover gaskets. Before fitting each cover fill the pump chamber with clean oil. Having assembled the pumps, lay the timing cover flat and fill the oil ports using an oil can. Turn the pump spindle with a screwdriver in a clockwise direction and it can then be checked whether the pumps are operating correctly. Before replacing the timing cover on the engine, fill the filter chamber with clean oil and fit the filter element.

NOTE: With the engine running, the oil feed to the big end can be checked by partially unscrewing the feed plug in the timing cover between the oil pumps and the oil return can be checked by slackening the rocker pipe banjo bolt on the cylinder head and observing the oil flow.

4. Removal of Pump Worm and Timing Pinion

Unscrew the pump worm using the hexagon head behind the worm, with special tool 2006. Withdraw the timing pinion using special tool 2013.

CAUTION: The worm nut has a left hand thread. When turned clock wise the worm nut can be loosened and when turned anti-clockwise the worm nut gets tightened.

NOTE: When refitting the timing cover ensure that the cork is in position in the worm nut and is undamaged. This forms a seal between the oil feed plug and the oil passage in the crank shaft, timing side. If necessary this should be replaced and care should be taken to have it fitted correctly.

CAUTION: If this cork is not fitted or damaged, the oil feed to the big end bearing through the timing shaft will tend to escape past this point causing starvation of lubrication to the big end bearing leading to premature failure of the big end floating bush, engine bearings and other parts.

WORKSHOP MANUAL BULLET

5. Removal of Contact breaker housing.

Loosen the distributor pinion nut and pull out the distributor pinion off the distributor shaft after removing the idler pinions.

Loosen and remove the three screws which secure the spigotted contact breaker housing and separate from crankcase. Remove the contact breaker cover. Remove the base plate after removing the two hex bolts securing it.

Pull out the contact breaker shaft from the housing. The two sintered bushes provided in the housing would have to be replaced only if excessive radial play is noticed on the distributor shaft.

Reassembly is just the reverse process of dismantling but take care to replace the washer between the contact breaker housing and the crank case.

6. Valve Timing

The cams are integral with the cam pinions. They have internal sintered iron bushes running on fixed spindles in the timing chest.

The cams and the timing pinion are provided with timing marks to set proper valve timing. The procedure is detailed below.

Bring the piston to TDC position. Match the exhaust cam (provided with two sets of punch marks) with the timing pinion so that the two punch marks coincide on both. Match the inlet cam to the exhaust cam so that the single punch marks coincide on both. Push the cams home towards the crankcase.

7. Tappet Adjustment – Cold

It is very essential to ensure that the valves are closed fully during the closing period of the cam. The tappet clearance should be adjusted properly to achieve this and to cater to certain amount of thermal expansion of the working components. We recommend 'NIL' clearance for the tappets to be set at cold. Provision for adjustment is given at the bottom end of the push rod which sits over the tappet. Access to this is by removing the tappet cover.

Proceed as follows for adjustments. Bring the piston to TDC at the end of compression stroke, so that both the valves are at the closed position. This may be ensured by seeing the valve timing marks, if the timing cover is open or through ammeter needle in its centre position, when ignition is switched on.

CAM TIMING MARKS

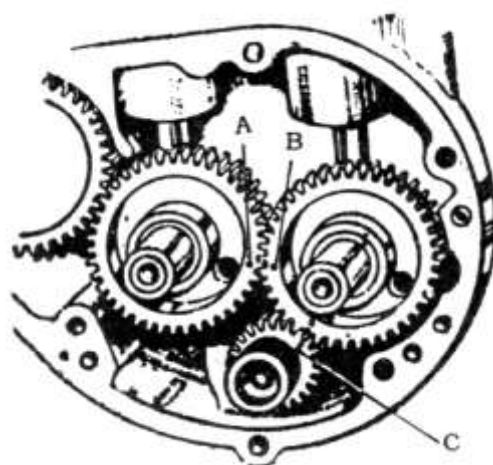

A: MARK ON INLET CAM
B: MARK ON EXHAUST CAM
C: MARK ON TIMING PINION

ADJUSTING TAPPETS



WORKSHOP MANUAL BULLET

Check the push rods. They must rotate thumb free without any up and down play.

In case the push rods do not rotate freely or if up and down play is noticed, the push rods need to be adjusted.

Loosen the lock nut in the adjuster, by holding the top nut. Thread in or out, the bottom adjuster, till the correct push rod freeness is achieved. Retighten the lock nut after adjustments are complete.

CAUTION: If the cylinder head has been disturbed for any attention, ensure proper fitment of valve stem caps and rocker bearings before proceeding to tappet adjustment.

NOTE: Owing to the initial bedding down of the wearing surfaces, the tappets on new engines may require adjustment after the first few hundred kilometres of run.

8. The Clutch - 350cc and 500 cc

The 350cc clutch has five driven plates and four driving plates, including the friction disc on the sprocket.

The 500cc clutch is similar to that of 350cc except that there are six driven plates and five driving plates.

Also the lugs on the clutch sprocket and the splines on clutch centre are longer.

9. Removal of the Clutch

Remove the LH front footrest. Place a tray beneath the primary chain case to collect the oil in the chain case. Remove the centre nut in the chain case outer and remove the cover.

To remove the clutch unscrew the clutch spring pins. Lift away the spring cap, springs, clutch front plate, clutch pad in main shaft. The assembly of driving and driven clutch plates and the clutch retaining spring. The clutch sprocket can then be withdrawn along with the chain and engine sprockets (see point 10).

The clutch centre can be removed only after the engine sprocket, primary chain and the clutch sprocket has been removed.

To remove the clutch centre hold the clutch with a brake bar (Special Tool No. 2025) and remove the centre retaining nut and washer with a box spanner. The clutch centre can then be withdrawn from the shaft using extractor (Special Tool No. 2005).

WORKSHOP MANUAL BULLET

CLUTCH ASSEMBLY - 350

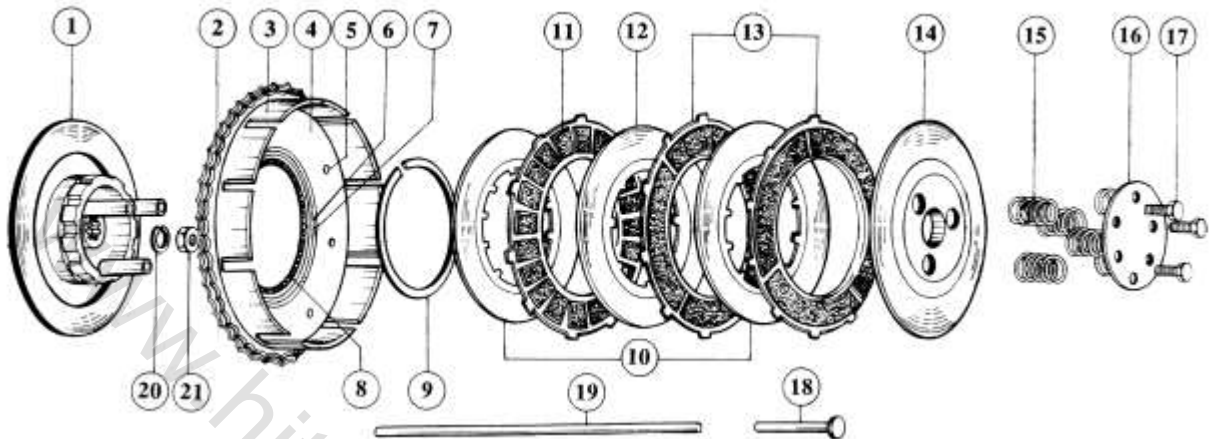

- | | |
|---|--|
| <ol style="list-style-type: none"> 1. Clutch centre and back plate assembly 2. Clutch sprocket 56 T & drum assembly 3. Clutch sprocket drum (N/S) 4. Clutch sprocket friction disc 5. Clutch sprocket friction disc rivet 6. Clutch sprocket ball cage (N/S) 7. Clutch sprocket ball cage rivets (N/S) 8. Clutch sprocket balls (3/16" dia) (N/S) 9. Clutch retaining spring 10. Clutch intermediate plate (dished) 11. Clutch plate (Insert type) | <ol style="list-style-type: none"> 12. Clutch intermediate plate (flat) 13. Clutch bonded plate assembly 14. Clutch front plate 15. Clutch spring 16. Clutch cap 17. Clutch spring screw 18. Clutch pad 19. Clutch rod 20. Washer main shaft (spring) 21. Nut main shaft (Nyloc) |
|---|--|

CLUTCH ASSEMBLY - 500

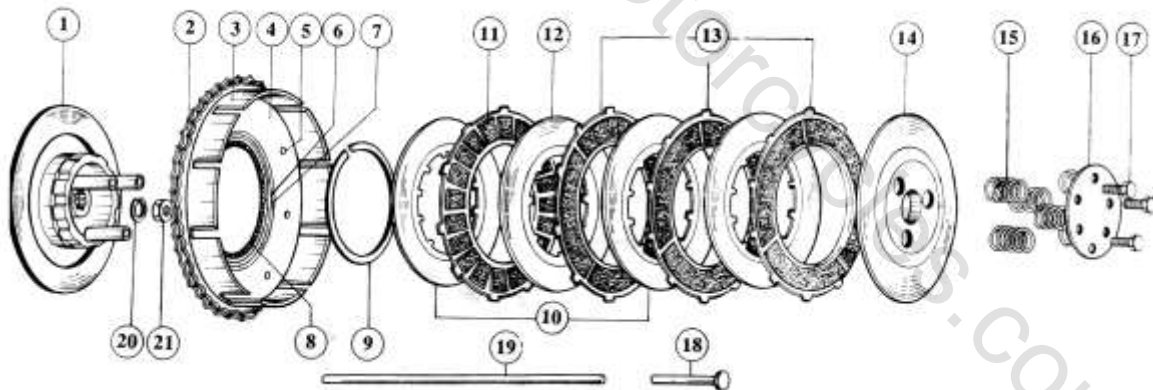

- | | |
|---|--|
| <ol style="list-style-type: none"> 1. Clutch centre and back plate assembly 2. Clutch sprocket 56 T & drum assembly 3. Clutch sprocket drum (N/S) 4. Clutch sprocket friction disc 5. Clutch sprocket friction disc rivet 6. Clutch sprocket ball cage (N/S) 7. Clutch sprocket ball cage rivets (N/S) 8. Clutch sprocket balls (3/16" dia) (N/S) 9. Clutch retaining spring 10. Clutch intermediate plate (dished) 11. Clutch plate (insert type) | <ol style="list-style-type: none"> 12. Clutch intermediate plate (flat) 13. Clutch bonded plate assembly 14. Clutch front plate 15. Clutch spring 16. Clutch cap 17. Clutch spring screw 18. Clutch pad 19. Clutch rod 20. Washer main shaft (spring) 21. Nut main shaft (Nyloc) |
|---|--|

WORKSHOP MANUAL BULLET

10. Removal of Engine and Clutch sprockets

Remove the alternator stator by undoing three nuts. The primary chain is endless hence it is necessary to remove both the engine and clutch sprockets simultaneously. Remove the central hexagon nut securing the alternator rotor, which can then be drawn off, taking care not to lose the key. The engine sprocket is mounted on splines and can be removed along with the clutch sprocket using extractor 2004.

11. Removal of Final Drive Sprocket

Remove the clutch as described above. Remove the primary chain tensioner. Remove the primary chaincase inner by removing three nuts. Remove the folding of the tab washer which is provided for locking the final drive sprocket nut. Hold the sprocket and remove the nut (right hand thread). The sprocket can then be withdrawn.

12. Re-assembly of the Clutch Plates

When re-assembling the clutch plates the following order must be observed. The clutch pad must be fitted into the main drive shaft, plain dished plate (dish projecting out wards), friction plate with inserts, plain flat plate, friction plate bonded, plain dished plate (dish projecting inwards) friction plate bonded, clutch front plate, 3 springs on the clutch centre lugs.

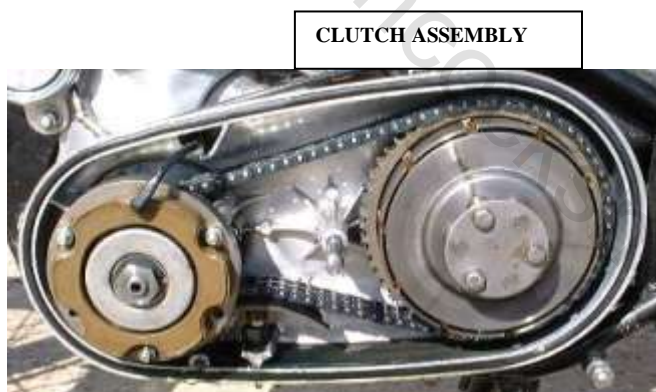

In the case of 500cc one more plain flat plate and one friction plate will also have to be fixed after the plate with inserts has been assembled.

The other three springs are located by means of bosses on the clutch cap. Tighten the spring pins as far as they will go. If the clutch lifts unevenly, it is probable that one of the springs has taken a set, in which case new spring should be fitted.

The friction plate with inserts should be renewed if badly worn or when the inserts have become loose in their plate. The bonded friction plates require renewal when worn or charred. (A light change to a blackish colour should not be mistaken as charred).

Excessive or premature wear of the plates is due to either running the vehicle at half clutch application or depriving the clutch plates of oil, with insufficient or no oil in the clutch chain case.

13. Primary Chain Adjustment

Access to the primary chain adjuster is gained by removing the primary chain cover which is held in position by a single nut. Before removing the nut, place a tray under the engine to collect the oil

WORKSHOP MANUAL BULLET

PRIMARY CHAIN ADJUSTMENT

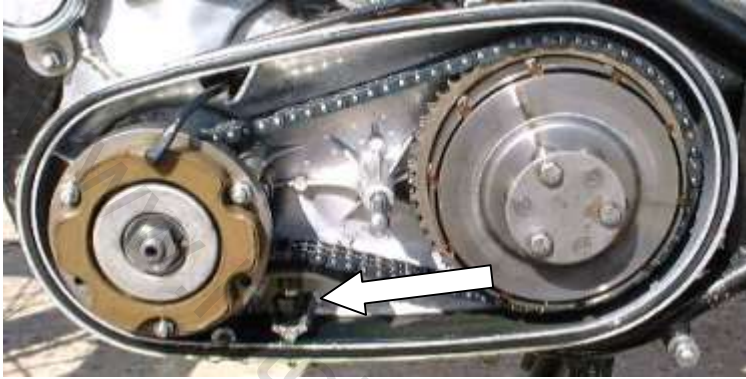

The chain should be adjusted so that there is 1/4" up and down movement at the centre of the top run of the chain. Remember to check the chain tension at 3 or 4 places and then adjust accordingly. Ensure that the chain tensioner pad moves freely and the lock nut of the adjuster is retightened after carrying out the adjustment. The chain is to be renewed if its length has increased by 3/4" than the length of a new chain.

After replacing the chain cover, remember to replenish the chaincase with oil (SAE 20) up to the level plug in outer chain case (approx. quantity 430 to 450 ml.)

14. Adjustment of the Clutch control

It is essential that there should be about 3 to 4mm free movement in the clutch cable, to ensure that all the spring pressure is exerted on the plates.

There are 2 points of adjustment on the clutch cable. The first is the midway adjuster at the middle of the cable just above the chain case. The adjustment is made by screwing the adjuster screw in or out of the adjuster body. Tighten the locknut on the screwed collar after adjustment has been made.



CLUTCH ADJUSTMENT ON GEARBOX

The other point is at the handle bar end. Loosen the lock nut and thread in the adjuster to increase play and vice versa to reduce play. Tighten lock nut after carrying out adjustment. However if the adjusters have reached their maximum position then the adjustment can be carried out in the gear box outer cover. Before proceeding on the adjustment, turn in both cable adjusters to their fully closed position (fully in position).

To make the adjustment, remove the inspection cover, slacken the locknut and turn the central screw in, to get the desired free play on the clutch lever at the handle bar end. Tighten the locknut after adjustment has been made.

WORKSHOP MANUAL BULLET

Owing to initial bedding down of the clutch plate inserts, the clutch control may require adjustment after the first few hundred Kms with a new machine. This point should therefore be examined soon after delivery and adjustment made if necessary. Initially, excessive play in the cable can be taken up through midway adjuster and the adjuster at the handle bar end.

NOTE: The clutch adjuster ball and clutch rod may require cleaning and greasing around 6,000 miles/10.000Kms of run. To do this, loosen and carefully remove the clutch adjuster from its position, taking care not to drop it into the gear box outer cover.

Start the engine and tilt the motorcycle towards the gear box side, so that the clutch rod can be removed. Wash thoroughly, the clutch rod and adjuster and look for chipped or worn clutch rod ends and free rotation of the clutch adjuster ball.

Smear multipurpose grease on the clutch rod and reassemble into the mainshaft. Smear grease on the clutch adjuster ball and carefully reassemble in its location. Adjust the adjuster to ensure free play is maintained on handle bar end and tighten lock nut.

15. Fitting the Alternator

The alternator consists of two parts, the stator and the rotor. The stator is mounted on to the primary chaincase inner by three studs and nuts.

The rotor, which contains the permanent magnet, is mounted on the end of the drive shaft and is located by a key and secured by a special nut and spring washer. The designed radial air gap between the rotor and the poles of the stator is 0.25mm (0.010") and care must be taken when refitting to see that it is not less than 0.15mm (0.006") at any point.

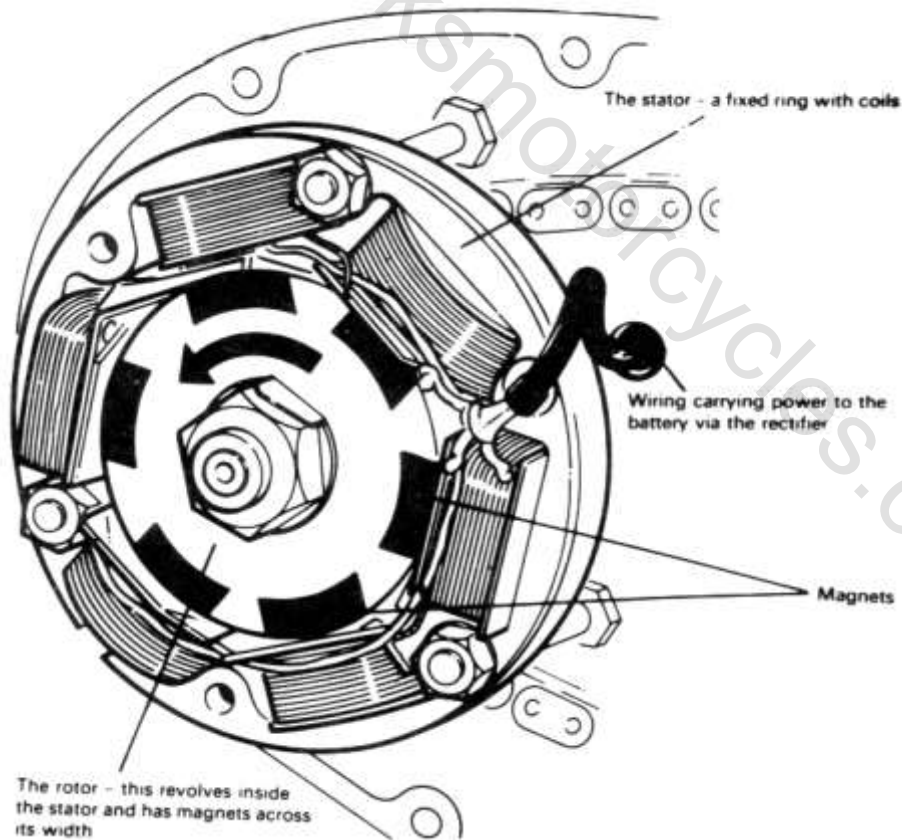

WORKSHOP MANUAL BULLET

Fit the rotor first, making sure that it is located concentrically on the end of the drive shaft. Attention must be given to the proper seating of the key. Finally secure the rotor with the appropriate washer and nut.

Having fitted the rotor, the stator may then be fitted on to the chaincase inner with the coil connections facing outwards. Replace the shake proof washers and the nuts on the studs and tighten gently. Insert six strips (preferably non magnetic material) 0.15mm (0.006") thick and 25.4mm (1") wide. Check whether the strips are free in position. If one or more of the strips are not free, gently tap stator (at the opposite end) to centralise the same, such that all the strips become free. Tighten the stator nuts and ensure the strips move freely. Gently crank engine, recheck the strips are free. Repeat this process at 3 or 4 places and then withdraw the strips.

16. Function of Breather

The efficient operation of the breather is of paramount importance to the performance of the engine because it acts as a non-return valve between the crank case and outside atmosphere, causing a partial vacuum in the crankcase and rocker boxes which prevents the passage of oil into the cylinder. If the breather is not acting efficiently it may cause pressure in the crankcase instead of partial vacuum, giving rise to smoking or oiling of the plug.

17. Gear Box

The gears, ratchet mechanism etc, of the gearbox can also be serviced without dismantling the engine from the frame.

Please refer page 33 for dismantling the gearbox.

WORKSHOP MANUAL BULLET

SERVICE OPERATIONS

ENGINE REMOVED FROM FRAME

1. Removal of the Engine from the Frame

A. Disconnect alternator leads, B. Disconnect the spark plug cap. Suppressor cap C. Turn off petrol tap and disconnect the fuel pipe, D. Remove carburettor assy. along with throttle cable, E. Remove the air filter assy., F. Remove the exhaust pipe and silencer, G. Disconnect the engine steady bolt, H. Remove the rear chain, I. Remove the footrest (LH.), J. Support the engine on a suitable box or wood block, K. Remove the centre stand and the stand stop, L. Remove the front engine plates and the small bolt fixing the stand spring bracket and fix the rear mudguard, M. Remove the stud securing the rear engine plate to the frame, N. Slide out the engine.

2. Removal of the Gearbox

Remove the primary chaincase outer, clutch assembly, stator and rotor, engine sprocket and clutch sprocket. Remove the clutch centre and chain case inner.
Remove four 3/8" nuts and the gearbox can then be withdrawn from the engine.

3. Dismantling the Crankcase

Drain the oil tank by removing the feed and return filter assembly plugs located in the crankcase bottom.

Having removed the engine from the frame dismantle the cylinder head, barrel, piston, timing gear, etc, as described in the chapter "Decarbonising".

Remove the nuts on the driving side of the engine from four fixed studs at the rear of the crankcase.

Remove six studs passing through the crankcase by undoing nuts.

The two halves of the crankcase can then be separated.

The driving side outer race of bearings will remain in the driving side half of the crankcase.

The driving side bearing inner race and the inner distance piece will remain on the engine shaft. (Crank shaft)

The flywheel assembly may be removed from the driving side of the crankcase.

4. Removal and Reassembly of main bearings

1. Clean the crank case thoroughly as any trace of oil in the crankcase will burn and discolour the bearing race while heating the crank case.

2. Heat the crankcase in an oven or apply the naked flame of a blow lamp on the circumferential area of the bearing boss and not directly on the bearing race. When the crankcase gets heated up fairly, tap the crankcase on a wooden block (with bearing race facing downwards) gently so that it will drop down due to the expansion of the bearing boss.

3. Remove the circlip from the driving side crankcase and reheat to remove the ball bearing.

WORKSHOP MANUAL BULLET

Inspect the bearings before assembly. The bearing should spin smoothly. Rotated dry, it may appear to be slightly noisy but there should be no signs of corrosion, nor must there be any appreciable radial slackness. The outer race of the roller bearing must be preferably smooth and bright with no evidence of cracks or pitting. The individual rollers must show no signs of wear and should rotate smoothly in the cage. It is recommended to replace with new bearings, once they are removed from the crankcase.

Reheat the crank cases to reassemble the bearings in the crankcase. Assemble the ball bearing in the D/S crankcase after fitting the circlip. Locate the other circlip, distance tubes outer and inner and then assemble the roller bearing outer race.

Ensure that the bearings are seated properly in the crank case and the outer roller race is flush with the crank case.

TIMING SIDE ROLLER BEARING ASSEMBLY

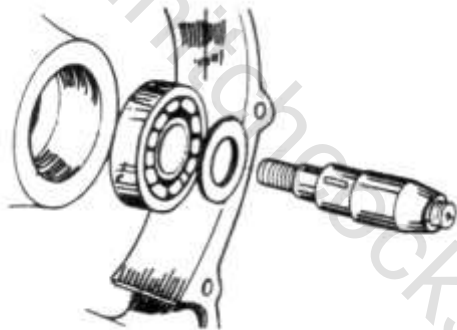

DRIVING SIDE BEARING ASSEMBLY

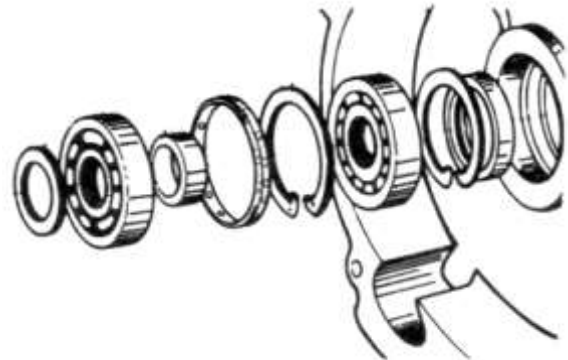

5. Replacement of the Cam Idler Spindles

When wear is noticed or step formation seen on the spindle, it should be replaced. To remove the cam spindle, heat the crankcase and tap the spindles out from inside.

To remove the idler pinion spindles, heat the crankcases as before, hold the spindles in a vice and tap the crankcase lightly with a nylon/wooden hammer.

To replace the cam spindles, locate the spindles in respective holes in the timing side crankcase and drive the spindles in home with a small hammer (1/2 lb.) and a drift. Make sure that the spindles are upright and parallel to each other.

6. Connecting Rod

Wear in the hardened steel big end bush will be shown by a formation of a ridge round the centre of the bearing surface corresponding with the oil groove in the white metal floating bush. If this wear is excessive the connecting rod should be replaced.

Excessive wear on the small end of the connecting rod can be easily seen. The gudgeon pin will show a rocking motion if wear is excessive.

CONNECTING ROD

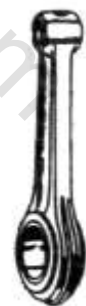

WORKSHOP MANUAL BULLET

7. Flywheel Assembly

The flywheel assembly consists of the crankshaft and the connecting rod.

To dismantle the crankshaft remove the set screws securing the crankpin nuts. Holding the crankshaft in a special jig (2037) remove the crankpin nuts.

Using 2037, with a pair of steel bars (about 1" x 3/8 x 9" long) placed across, between the flywheel disc, press out the crankpin using a hand press.

The connecting rod can then be removed along with floating bush.

Turn the crankshaft over in the jig and repeat with other side if necessary. To remove the timing shaft, remove the set screw from the shaft nut and unscrew the nut. Drive the shaft out with a hammer and drift.

To replace the timing side shaft, reverse the above process, making sure that the key is a good fit and that the nut is tightened securely by means of a box spanner with a 12" tommy bar.

The driving shaft has no nut but is secured by tightening the sprocket nut after the assembly of the engine. It should be pressed in with a hand press or a hammer and drift. If the latter is used care must be taken not to damage the centre. It has a collar which butts against the flywheel disc.

To reassemble the crankshaft, press the crankpin into the timing side flywheel, making sure that the oil hole is in the correct position and the thrust washer is facing the right way. ie. with chamfer away from the flywheel.

Test the oil passages using an oil can to make sure that they are clear.

Assemble the floating bush over the crankpin.

Assemble the connecting rod over the floating bush and smear engine oil.

Place the other thrust washer over the crankpin, also with the chamfer away from the flywheel.

Use a brass drift and hammer for pressing the D/S flywheel.

Locate the flywheel in the assembly jig, to ensure that the flywheels and shafts are in line and replace the nuts, tighten securely and refit the set screws.

Test the oil passages again to ensure that they are clear.

If the same crankpin has been put back, it will be necessary to drill out the old grub screw, in order to clean the oil passages after which a new grub screw must be fitted.

Mount the crankshaft between the centres of a lathe or on a pair of "v" block and true up to .001" on either side of the shafts.

If the readings for the two shafts are high on opposite sides, the error can be corrected by gently tapping either or both of the flywheels.

If the readings are high on the same side of the two shafts, it is probably due to dirt or foreign matter in the joints and the crankshaft should be dismantled again, carefully examined and cleaned and re-assembled.

FLYWHEEL ASSEMBLY

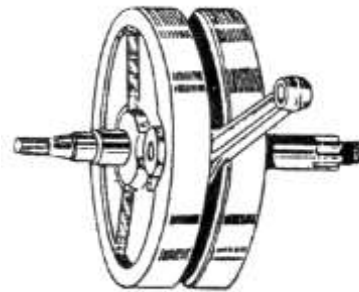

FLYWHEEL IN A JIG

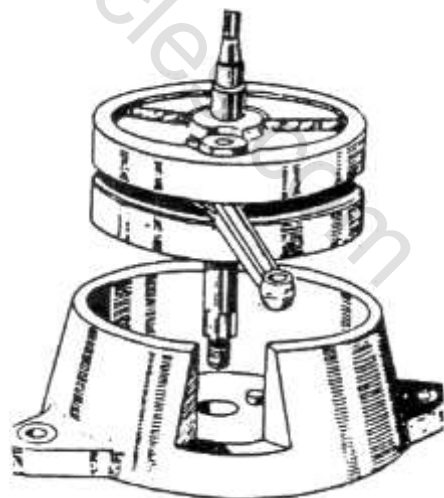

WORKSHOP MANUAL BULLET

8. Re-assembly of the Crankcase

Replace the bearings, etc., in the crankcase halves after heating the crankcase as described earlier. (Refer page No 29)

Fit the inner distance piece in the driving side crankcase.

Fit the thrust washer on the drive shaft. Fit the bearing inner race on the drive shaft. Assemble the flywheel into the bearing if necessary using the sprocket nut with a suitable spacer to draw the driving shaft through the inner race of the ball bearing.

Make sure that the crankcase face is clean and apply jointing compound to it and fix the crankcase gasket in position.

Put the thrust washer on the timing side shaft and press the bearing inner race.

Place the timing side crankcase in position over the flywheel and gently tap with a wooden mallet.

Bolt the two halves of the crankcase together, making sure that the joint matches correctly so that the cylinder base is flat.

Rotate the drive shaft by hand and check for freeness to ensure correctness in assembly and press the oil seal on to the drive side of the crankcase from outside, ensuring proper seating.

For 500cc

Press the oil seal on the timing side of the crankcase and ensure proper seating. (Spring facing in to the timing cover).

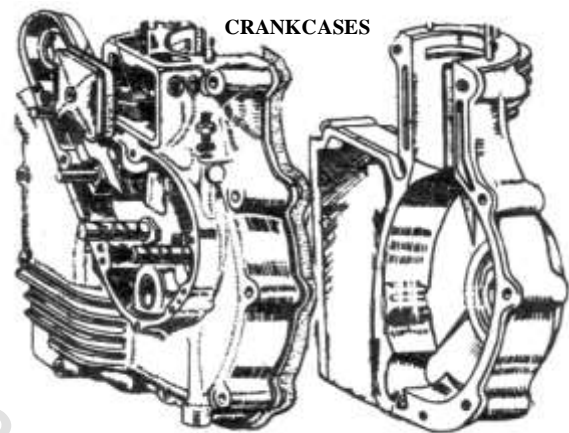

WORKSHOP MANUAL BULLET

GEAR BOX

NOTE: Before attempting to remove the internal parts, please ensure that the clutch assy has been dismantled along with F.D. sprocket

1. Removal of Gear box from engine

This has already been described earlier

2. Dismantling the Gearbox

The gear box can be completely dismantled with the engine in the frame except for the removal of the inside operator and the bearings in the gear box case. Remove the kick starter crank, the gear change lever and the neutral finder. Remove the top and bottom small inspection covers and disconnect the clutch cable, after loosening clutch adjuster. Remove four screws and the gear box outer cover can then be detached. Remove the foot control plate assembly and foot control short by taking off the two nuts securing it. Remove the main shaft bearing cover

CAUTION: Hold the kick starter returning spring eyelet by means of a long screwdriver to prevent it from rebounding (and causing damage) while the main shaft bearing cover screw is removed.

The main shaft can be drawn straight out, if the clutch has been removed, which, however, should be done before taking off the gear box inner cover. The top gear pinion and dog will come away with the mainshaft.

The layshaft can then be removed and the second and third gears drawn off the final drive sleeve together with the operator fork.

NOTE: To take out the main shaft sleeve, the final drive sprocket must be removed and this is preferably done before removing the inner cover.

3. Removal of the Ball Bearings

The mainshaft ball bearings can be removed by using a stepped drift of 0.437" (11 mm) & 1.171" (29.77mm) in diameter for the bearing in the case and 0.812" (20.64 mm) & 0.515" (13.1 mm) in diameter for the bearing in the cover.

When refitting the bearing stepped drifts of 2.31" (58.7mm) & 1.171" (29.7mm) diameter and 1" (25.4mm) in diameter, must be used for bearings in the case and cover respectively.

4. Gear Change Mechanism

If the two pins securing the gear change ratchet mechanism are slackened, the adjuster plate can be set in the desired position. In this position the movement of the gear lever, necessary to engage the ratchet teeth will be approximately the same in each direction.

If the plate is incorrectly adjusted, it may be found that, after moving top to third or from bottom to second gear, the outer ratchets will not engage the teeth on the inner ratchets correctly.

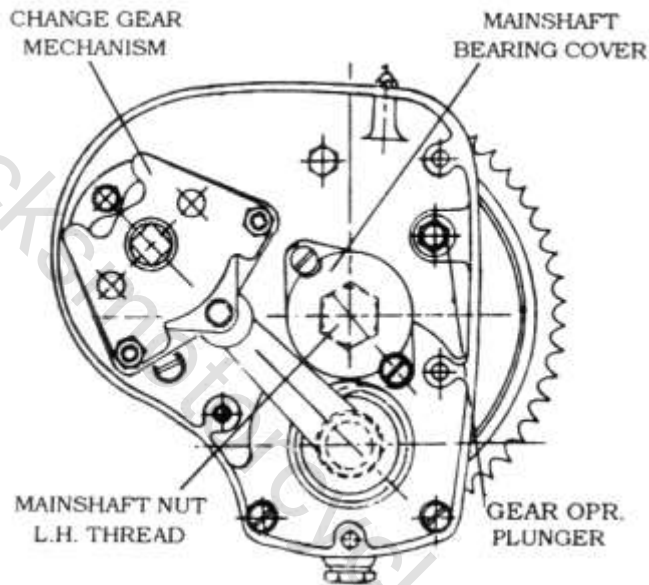

WORKSHOP MANUAL BULLET

CHANGE GEAR MECHANISM

When fitting new parts, if it is found that the gears do not engage properly; ascertain whether a little more movement is required or whether there is too much movement so that the gear slips right through second or third gear into neutral. If more movement is required, even after adjusting the adjuster plate then this can be obtained by filing the foot control stop plate very slightly at the points of contact with the pegs on the ratchet ring.

If too much movement is already present, a new foot control stop plate giving less movement must be fitted.

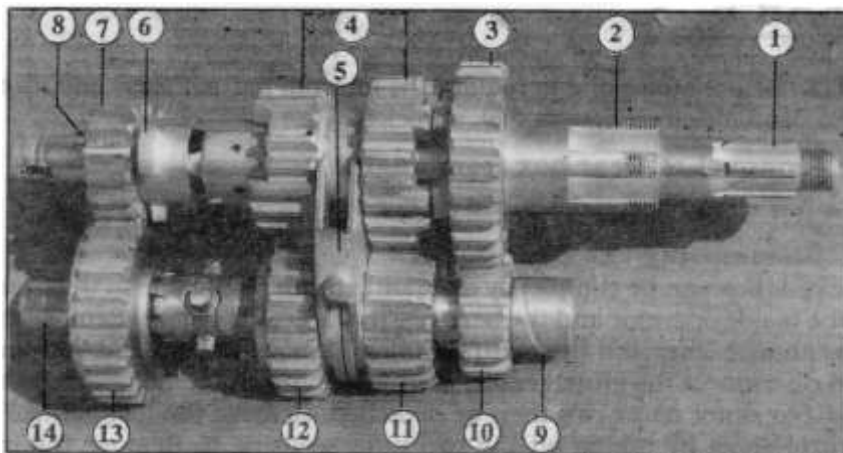

1. Main shaft
2. Main Shaft sleeve
3. Main shaft low gear pinion 25T
4. Main shaft sliding gear 21T & 18T
5. Gear operator fork
6. Main shaft high gear pinion dog
7. Main shaft high gear pinion 15 T
8. Main shaft oil thrower inner
9. Lay shaft splined bush
10. Lay shaft low gear pinion 15T
11. Lay shaft second gear pinion 19T
12. Lay shaft third gear pinion 22T
13. Lay shaft high gear and K/S wheel 25T
14. Lay shaft

4.1 Gearbox with Continental controls.

GEAR BOX WITH CONTINENTAL CONTROLS

The procedure for dismantling the gearbox with continental controls is the same as described earlier.

While dismantling the gear change mechanism care should be taken to disconnect the foot control lever from the gear shift shaft after loosening the hex bolt. The circlip provided on the gear shift shaft should also be removed prior to removing the inner cover.

Grease nipples are provided on the shift shaft and gear lever on the left side of the motorcycle for periodical greasing to ensure smooth operation of shift shaft and gear lever.

If excessive gear lever travel is noticed and gear engagement becomes difficult, the plastic bushes provided at the gear linkages would have worn out and will have to be replaced with new bushes to reduce play in the linkage.

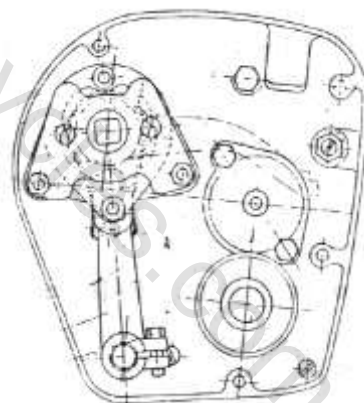

WORKSHOP MANUAL BULLET

EXPLODED VIEW OF GEAR BOX ASSEMBLY

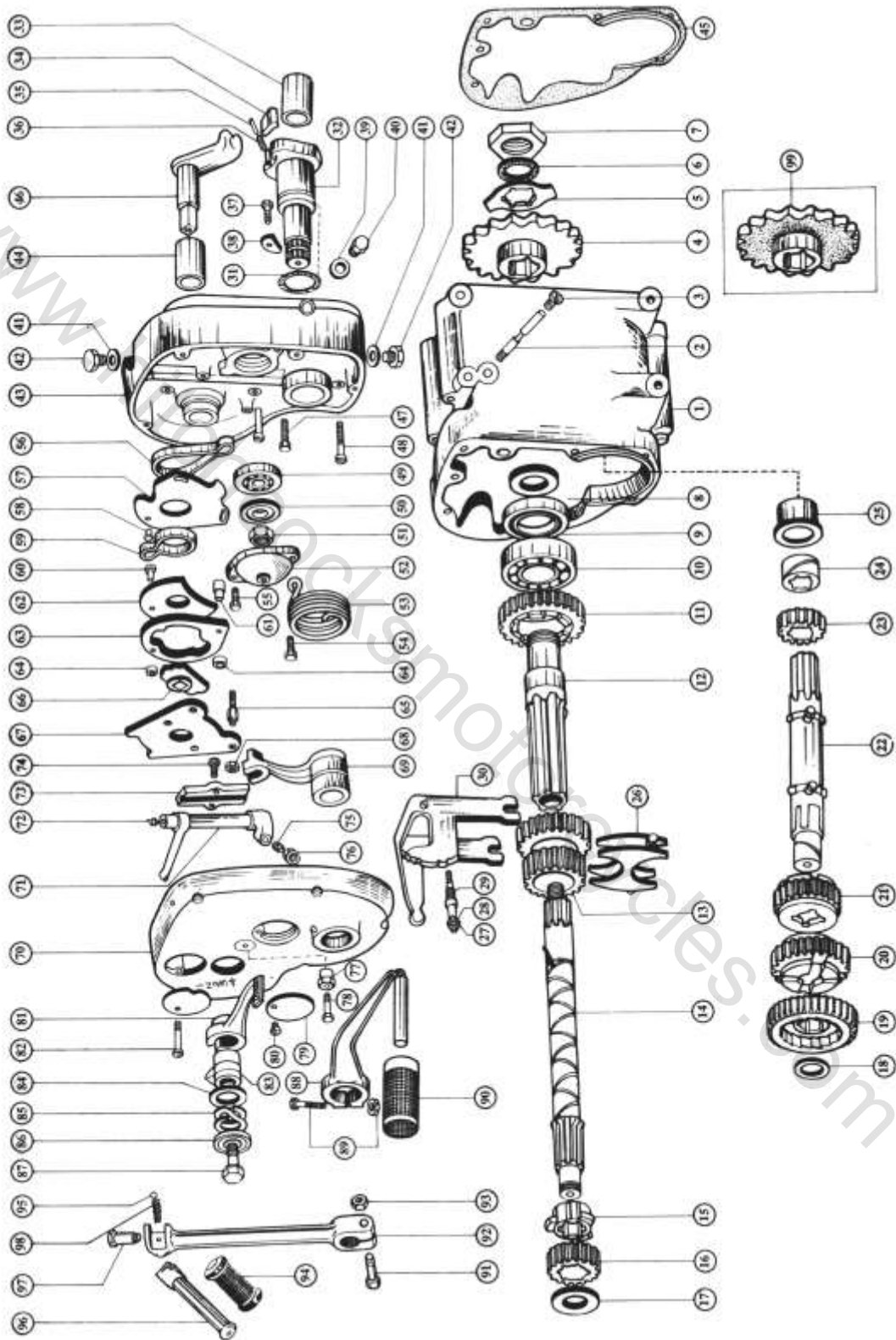

WORKSHOP MANUAL BULLET

GEARBOX DESCRIPTIONS

- | | | |
|---|--|--|
| 1. Gear box case with bush | 36. Plunger spring | 70. F/c cover c/w Clutch lever, bearing cap & pins |
| 2. Gear operator pin | 37. Stop plate bolt | 71. Clutch lever |
| 3. Bush gear operator pin | 38. Stop plate | 72. Clutch lever grease nipple |
| 4. Drive sprocket (16-T) | 39. Washer oil level plug | 73. Clutch lever bearing cap |
| 5. Lock washer (D/sprocket) | 40. Oil level plug | 74. Clutch lever bearing block pin (1/4" x 3/16") |
| 6. Lock nut felt washer | 41. Washer oil filler & drain plug | 75. Clutch lever adjuster assy |
| 7. Lock nut (D/sprocket) | 42. Oil filler & drain plug | 76. Nut clutch lever adjuster |
| 8. Drive sprocket distance piece | 43. End cover with bush | 77. Neutral lever eccentric bush |
| 9. Oil seal | 44. Bush foot control operator shaft | 78. Neutral lever stop pin |
| 10. Main shaft ball bearing (Large) | 45. Washer gear box case joint | 79. Clutch adjustment inspection cap |
| 11. Main shaft low gear pinion (25T) | 46. Foot operator shaft with lever | 80. Inspection pin short |
| 12. Main shaft sleeve | 47. Gear box cover bolt | 81. Neutral lever |
| 13. Sliding gear (21T & 18T) | 48. Gear box cover screw | 82. Cap pin (long) |
| 14. Main Shaft | 49. Main shaft ball bearing (small) | 83. Gear Indicator |
| 15. High gear pinion dog | 50. Oil thrower (outer) main shaft | 84. Washer for neutral lever spring |
| 16. High gear pinion (15T) | 51. Main shaft nut (LH Thread) (F/s end) | 85. Neutral lever spring |
| 17. Oil thrower (inner) | 52. Ball bearing cap | 86. Spring cap |
| 18. F/s spindle distance washer | 53. F/s return spring | 87. Neutral lever securing pin |
| 19. Lay shaft high gear & K/s wheel (25T) | 54. Cap pin (Long) | 88. Foot change lever |
| 20. Third gear pinion (22T) | 55. Cap pin (Short) | 89. Pinch bolt & nut |
| 21. Second gear pinion | 56. F/c lever return spring | 90. Foot change lever rubber |
| 22. Layshaft | 57. Adjuster plate | 91. Bolt kick starter crank |
| 23. Low gear pinion (15T) | 58. Spring stop | 92. Kick starter crank |
| 24. Splined bush | 59. F/c ratchet spring | 93. Nut kick starter crank bolt |
| 25. Bush (case) | 60. F/c plate spring stop | 94. Rubber kick starter crank |
| 26. Gear operator fork | 61. Ratchet operating pin | 95. Kick starter pedal pawl |
| 27. Nut gear operator (Inside) | 62. F/c plate | 96. Kick starter pedal |
| 28. Washer gear operator selector | 63. Ratchet (outer) | 97. Kick starter pedal pivot pin |
| 29. Gear operator selector assembly | 64. F/c plate pin bush | 98. Kick starter pedal spring |
| 30. Gear operator (Inside) | 65. F/c adjuster plate pin | 99. Drive sprocket (17 T) For 500 cc |
| 31. F/s spindle '0' ring | 66. F/c Ratchet (Inner) | |
| 32. F/s spindle with bush | 67. F/c stop plate & spring retainer | |
| 33. Lay shaft bush | 68. Nut (F/c adjuster plate) | |
| 34. Foot starter pawl | 69. F/c Lever short (Inside) | |
| 35. Plunger | | |

Note: F/s means Foot starter
F/c means Foot control

WORKSHOP MANUAL BULLET

5. Re-assembling the Gear box

The procedure is the reverse of that given above for dismantling but the following points should be noted.

If the main shaft top gear pinion and dog have been removed, make sure that the dog is replaced the right way round or third and top gears can be engaged simultaneously.

Make sure that the trunnions on the operator fork engage with the slots in the inside operator.

See that the main shaft is pushed right home. (It may be tight because of the felt washer inside the final drive shaft nut).

The layshaft top gear and kickstarter pinion should be assembled on the layshaft and the kickstarter shaft and ratchet assembled on to it before fitting the end cover. Do not forget the washer on the layshaft between the kickstarter pinion and kickstarter shaft.

The joint between the gear box and the inner cover should be made with shellac or any similar jointing compound.

Make sure that all parts are clean before commencing assembly. The gear box should be packed with soft grease (veedol '00' grease or equivalent) filled up to the correct level.

On no account must heavy yellow grease be used.

6. Adjustment of the Neutral Finder

The neutral finder is adjusted by means of an eccentric stopper secured to the front of the gear box cover by a bolt which limits the travel of the operating pedal. Slacken the bolt and turn the eccentric stopper until the correct movement of the pedal is obtained.

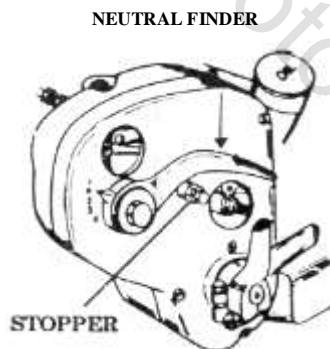

7. Lubrication of the Gear box

Current machines have the gear box filler plug at the top of the box and a level plug at the rear. Remove both plugs and fill, with the machine on level ground until the oil commences to flow from the level plug.

Check the level every 800 to 1,600 Km. when the gearbox is warm.

For initial filling up of gear box VEEDOL '00' grease is recommended. During routine maintenance, topping up may be done with SAE 50 oil.

The capacity is 700 grams (Approx.) of '00' grease mixed with SAE 50 grade oil to a thick consistency.

WORKSHOP MANUAL BULLET

LUBRICATION SYSTEM

Lubrication system is by Dry Sump and effected by an automatic and positive double action oil pumps.

The oil tank is integral with the crankcase, for ensuring the full rate of oil circulation immediately when the engine is started and for rapid heating of the oil in cold weather. The capacity of the oil sump is 2.25 Liters. (SAE 50 grade). There are two piston type oil pumps running at 1/12 of engine speed positively driven by the worm gear on the timing shaft.

The feed pump is at the rear of the timing cover (Left side when viewed from the front) and pumps oil from the oil tank, through the oil filter to the big end through the timing shaft. After lubrication of the big end bearings, the oil splashes and lubricates the cylinder barrel walls and drains to the bottom of the crankcase.

The return pump (front side of the timing cover) draws the oil from the crank case through the drilled passage and passes through the rocker oil pipe and lubricates the rocker bearings and valve spring mechanism and flows down through the push rod tunnels into the timing cover chest.

From here, the drained oil is pumped back to the oil tank through a hole (drilled in the RH crankcase) by the two idler pinions. The return pump has a capacity of approximately double that of the feed pump, which ensures that oil does not accumulate in the crankcase. If allowed to accumulate it will lead to smoke - oil splash through breather pipe and starvation of oil to rocker arm bearings.

Both pumps are double acting, but two sides of feed pump are inter-connected, thereby giving an augmented and even supply to the big-end. Return pump is also inter-connected for effective scavenging from crank case.

Gauze strainers are provided for both feed and return filters from the crankcase to ensure oil is free from dirt and sludge.

Oil Filter: The oil filter has a special and important feature in design. In the case of clogged filter or should it be neglected the oil pressure will lift the spring and cap off of its seat, thereby automatically by-passing the filter so that the big end bearings will not be deprived of lubrication, even though the oil may be dirty.

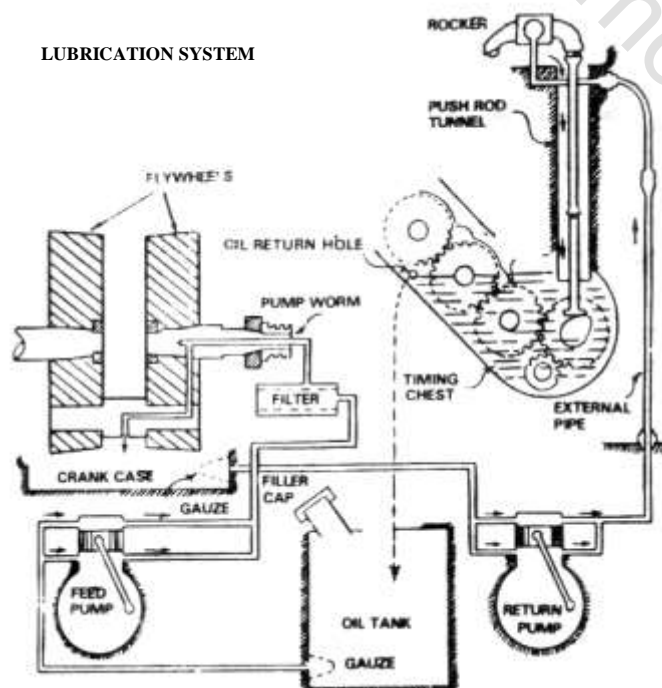

WORKSHOP MANUAL BULLET

OIL PUMP DIAGRAMS

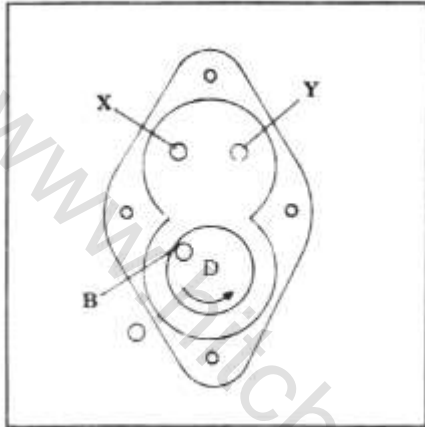

**FEED PUMP PORTS IN THE
TIMING COVER**

Y - Suction from Oil tank
X - Delivery to big end.

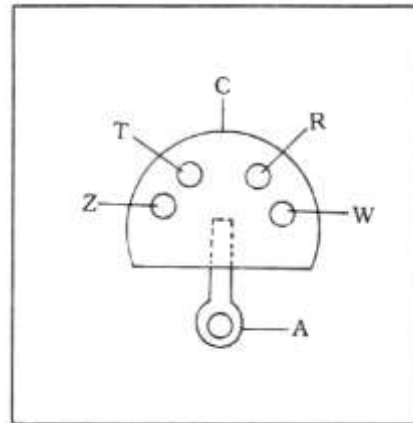

**FEED PUMP
PORTS IN FEED PUMP DISC**

T - Suction port
R - Delivery port
W, Z - Through holes

Position 1: The plunger A is drawn out of the feed pump disc C, by the peg B in the spindle D, due to its rotation.

The suction port T in the pump disc aligns with the suction port Y in the timing cover and oil from the tank is drawn into the pump disc as the plunger is drawn out.

Simultaneously the through hole W in the disc registers with the delivery port X in the timing cover.

The outward movement of the plunger forces the accumulated oil in the annular space in the timing cover to be delivered to the big end bearings through the oil filter element.

Position 2: As the pump spindle rotates further the plunger A is pushed into the pump disc C.

The delivery port R in the pump disc registers with the delivery port X in the timing cover. The oil in the pump disc is forced out through these ports, by the plunger for supply to the oil filter element and to the big ends.

Simultaneously the through hole Z, in the pump disc registers with the suction port Y in the timing cover and draws oil from the tank, into the annular space in the timing cover, due to inward movement of the plunger into the disc.

WORKSHOP MANUAL BULLET

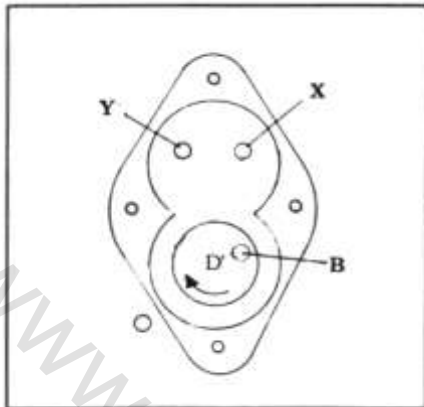

**RETURN PUMP
PORTS IN THE TIMING COVER**

**Y' - Suction from Crankcase
X - Delivery to Rockers**

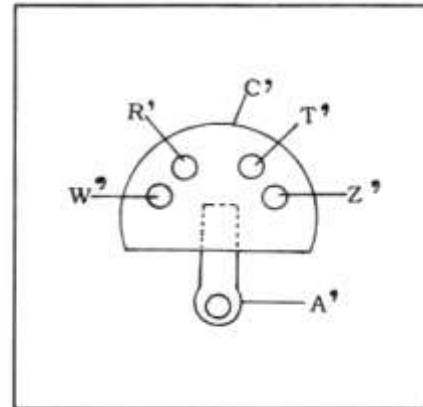

**RETURN PUMP
PORTS IN THE RETURN PUMP DISC**

**T' - Suction Port
R' - Delivery Port
W' Z' - Through holes**

Position 1: The plunger A' is drawn out of the return pump disc C' by the peg B on the spindle D, due to its rotation.

The suction port T' in the pump disc registers with the suction port Y' in the timing cover and oil from the crank case is drawn into the pump disc as the plunger is drawn out.

Simultaneously, the through hole W' in the disc registers with the delivery port X in the timing cover.

The movement of the plunger forces the accumulated oil in the annular space in the timing cover to be delivered to the cylinder head.

Position 2: As the pump spindle rotates further the plunger A' is pushed into the pump disc C'. The delivery port R' in the pump disc registers with the delivery port X in the timing cover. The oil in the pump disc is forced out through these ports, by the plunger, for supply to the cylinder head.

Simultaneously the through hole Z' in the pump disc registers with the suction port Y' in the timing cover and draws oil from the crank case chamber into the annular space in the timing cover due to inward movement of the plunger into the disc.

WORKSHOP MANUAL BULLET

FRAME REAR SUSPENSION

1. Description of Frame

The frame is built of special cold drawn welded steel tubing incorporating reinforcements wherever necessary, for extra strength.

The swinging arm unit forms the chainstay and is fitted with rubber bonded 'silent-bloc' bushes. The swinging arm unit is secured to the main frame by a long bolt passing through the pivot lugs.

2. Removal of Rear Spring Box Unit / Servicing Rear Spring Box

Remove the top pivot pin nut, drive out the pivot pin, then hinge the suspension unit back on the lower pivot pin. After removing the lower nut, the unit may be pushed off the pivot pin welded to the fork end. It is a sealed unit and the internal mechanism cannot be serviced. Outer dust cover can be removed using special tool PED- 2039 for cleaning coil spring.

REAR SPRING BOX REMOVAL



3. Removal of Swinging Arm Chain Stay

Remove the rear wheel, chain rear sprocket and brake cover plate assembly from the swinging arm chain stay. Remove one of the pivot nuts and pull the pivot pin from the other end. The chainstay can then be pulled out of the frame.

The life of the rubber bonded silent-bloc bushes is very high. But if it is necessary to replace the bushes, the inner sleeves will have to be pressed out first on a press. The rubber can then be taken away from the outer sleeves by pliers. The outer sleeves can be driven out by means of a hammer and a suitable drift.

Replace the rubber bonded bushes in the swinging arm, using a suitable drift, press one bush from one end of the pivot bearing tube under a press, until the metal outer sleeve is flush with the end face of the pivot bearing tube. While pressing, it must be ensured that pressure is exerted only on the outer sleeve and not on the inner sleeve of the bush, as axial pressure on the inner sleeve would destroy the bonding of the rubber to the metal sleeves. Similarly press the second bush from the other side of the pivot bearing tube until the metal outer sleeve is flush with its end face.

While assembling, the swinging arm fitted with rubber bonded 'silent-bloc' bushes, to the frame, the pivot nuts should be fully tightened only with the swinging arm positioned in the mid stroke of the spring boxes, i.e., when the centre distance between the spring box top mounting hole in the frame and the bottom mounting pin on the swinging arm is 9.75". This is recommended so that, the rubber bush will be subjected to minimum angular movement in either direction from the mid stroke.

WORKSHOP MANUAL BULLET

SWING ARM ASSEMBLY

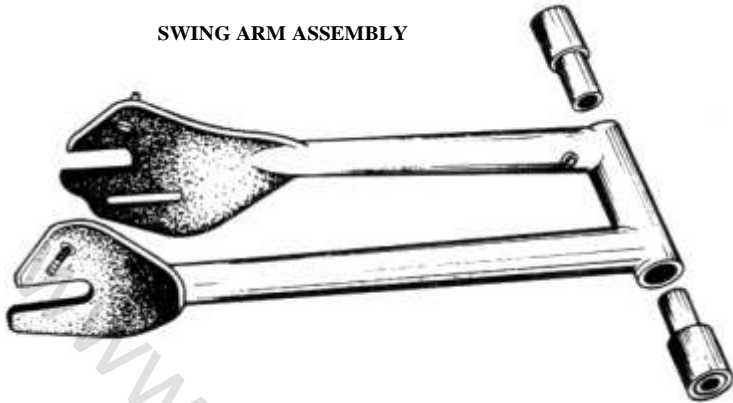

Position of the spring box.

The special tool for alignment of the swinging arm to be used. (2044). No maintenance is necessary for the swinging arm pivot.

4. Centre Stand

To remove the centre stand take out the split pins & washers from both the ends of the stand spindle. Drift out the spindle and withdraw the stand complete after disconnecting both the ends of the stand springs.

GUAGE FOR TIGHTENING
CHAIN STAY

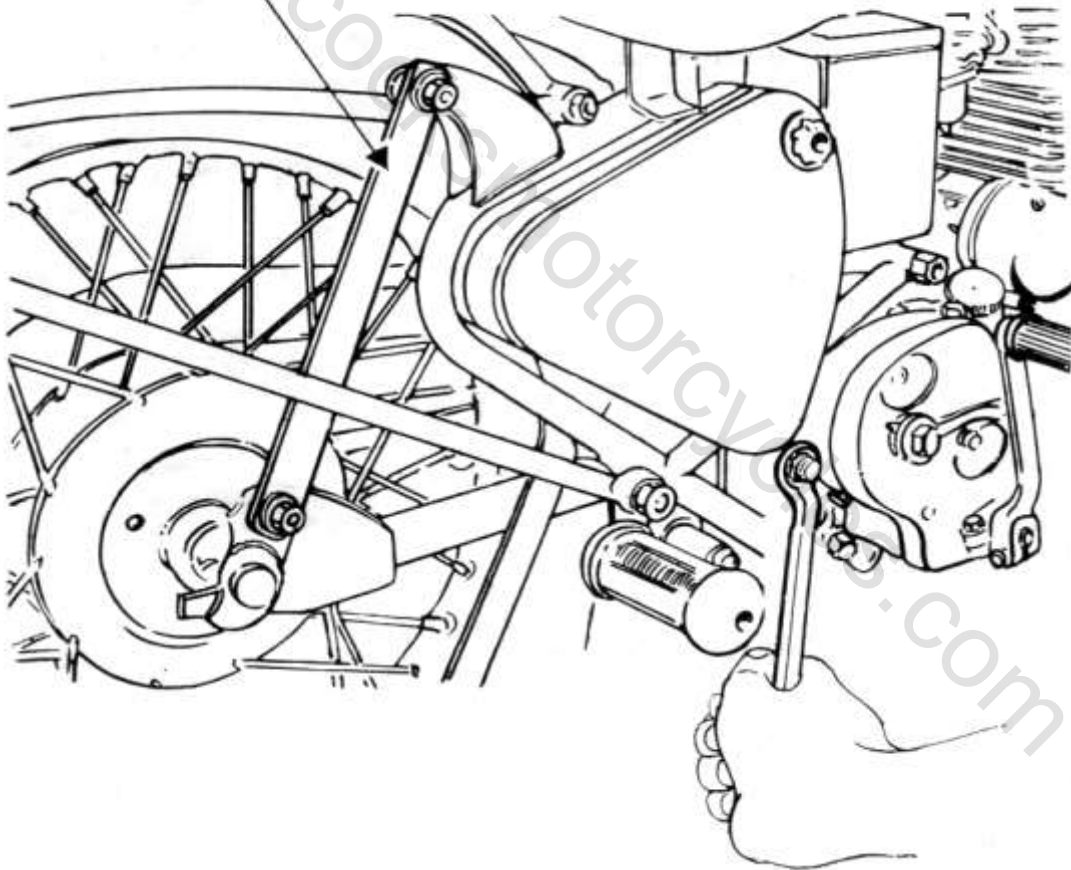

WORKSHOP MANUAL BULLET

FRONT FORK (Hydraulically damped)

1. Description

The telescopic fork consists of two legs each of which comprises a main tube of alloy steel tubing which is screwed into the Casquette fork head at the upper end and securely clamped to the fork crown. Fitted over the lower end of the main tube is the bottom tube made of high strength aluminium alloy with an integral lug which carries the wheel spindle. Fitted on the lower end of the main tube is a steel bush which is a close fit in the bore of the bottom tube. The upper end of the bottom tube carries a cast iron bush which is a close fit over the outside diameter of the main tube. These bushes are not being fitted on to the latest front fork assemblies. The bush is secured to the bottom tube by means of a threaded housing which contains two oil seals. A stud known as the 'spring stud' is fitted in the lower end of the bottom tube and a valve port is secured to the lower end of the main tube. As the fork operates oil is forced between the spring stud and the bore of the valve port forming a hydraulic damping system. A compression spring is fitted inside the main tube between the upper end of the spring stud and the upper end of the main tube. The lower end of the main tube and upper end of the bottom tube are protected by a cover secured to the fork crown.

2. Operation of the Fork

The fork provides a range of movement of 6" from the fully extended to the fully compressed position. The movement is controlled by the compression spring and by the hydraulic damping system. The hydraulic damping is light on the bump stroke and heavier on the rebound stroke, thus damping out any tendency to pitching or oscillation without interfering unduly with the free movement of the fork when the wheel encounters an obstacle or a pot hole.

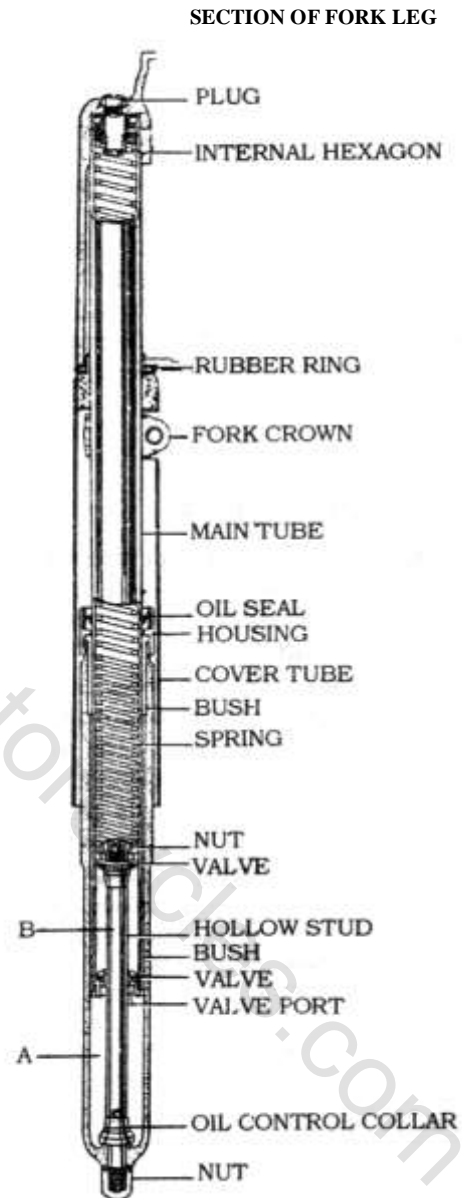

WORKSHOP MANUAL BULLET

The fork is filled with a light oil (S.A.E. 30) to a point above the lower end of the spring so that the damper chamber 'B' is always kept full of oil. Upward movement of the wheel spindle forces oil from the lower chamber 'A' through the annular space between the spring stud and the bore of the main tube valve port into the damper chamber 'B'. During this stroke the pressure on the underside of the valve plate causes this to lift so that oil can also pass from 'A' to 'B' through the eight holes in the valve body. Since, however, the diameter of chamber 'B' is less than that of chamber 'A' there is no room in 'B' to receive all the oil which must be displaced from 'A' as the fork operates. The surplus oil passes through the cross hole in the spring stud and up the centre hole in the stud, spilling out through the nut which secures the upper end of the spring stud to the guide at the lower end of the fork spring.

On the rebound stroke, the oil in the damper chamber 'B' is forced through the annular space between the spring stud and the bore of the main tube valve port. During this stroke pressure in chamber 'B' closes the two disc valves at the upper and lower ends of the chamber so that the only path through which the oil can escape is the annular space between the spring stud and the port. Damping on the rebound stroke is therefore heavier than on the bump stroke. At the extreme end of either bump or rebound stroke a small taper portion on the spring stud enters the bore of the valve port, thus restricting the annular space and increasing the amount of damping. At the extreme end of the bump stroke the larger diameter taper on the oil control collar enters the main counter-bore of the valve port thus forming a hydraulic cushion to prevent metal to metal contact.

3. Dismantling the Fork

Place the machine on the centre stand, disconnect the front brake control cable & speedometer connection and remove the front wheel and mudguard complete with stays. Unscrew the bottom spring, stud nut which will allow oil to run out of the fork down to the level of the cross hole in the spring stud. Now knock the spring stud upwards into the fork with a soft mallet, thus allowing the remainder of the oil to escape. Pull the fork bottom tube down as far as possible, thus exposing the oil seal housing. In the latest version the oil seal housing is eliminated and the oil seals are provided as an integral part of bottom tubes. Hence by pulling the bottom tube downwards the same can be removed from the fork main tubes. [For old type front forks: Unscrew this housing by means of a spanner on the flats

MAIN TUBE SPANNER 2036

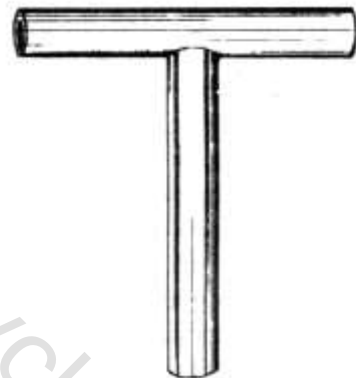

which it is provided. The bottom tube can now be withdrawn completely from the main tube leaving the bottom tube bush, oil seal housing and oil seal in position on the main tube.]

Now unscrew the main tube valve port using special tool 2026. The spring stud and spring can now be withdrawn from the lower end of the main tube.

NOTE: In the latest version the oil seal housing and steel bush has been eliminated on introduction of integral oil seals in the bottom tubes.

The steel main tube bush can now be tapped off the lower end of the tube, if necessary using the bottom tube bush for this purpose. Before doing this, however, it is advisable to mark the position of the bush with a pencil so as to ensure re-assembling it in the same position on the main tube. The reason for this is that these bushes are ground to size, after fitting on to the tubes, so as to ensure concentricity.

WORKSHOP MANUAL BULLET

After removal of the main tube bush, bottom tube bush and oil seal housing, the main tube can be removed using tool 2036. Before attempting to loosen the main tubes ensure that the 2 pinch bolts on the fork crown bottom has been sufficiently loosened to allow the main tubes to rotate.

4. Spring

The free length of the spring is 20 $\frac{1}{2}$ ". The spring should be replaced if it has closed by more than 1 inch.

5. Re-assembly

When refitting the oil seal, or fitting a new one, great care must be exercised not to damage the synthetic rubber lip which forms the actual seal.

NOTE: (Only for Old Type Forks) If the oil seal housing has been removed from the upper end of the main tube and is refitted from this end, a special nose piece must be fitted over the threaded end of the tube to prevent damage to the oil seal.

The spring stud is a tight fit in the hole at the lower end of the bottom tube. Once the stud has been located in the hole, push the bottom tube up sharply against the spring until two or three threads on the stud project beneath the end of the bottom tube. Now fit the nut and washer and pull the stud into position by tightening the nut. If necessary fit the nut first without the washer until sufficient thread is projecting to enable the washer to be fitted.

6. Removal of Complete fork Assembly

The fork complete with front wheel and mudguard can be removed from the machine, if necessary, by adopting the following procedure. The leads to the lighting switch and ammeter should be disconnected at their lower ends or by means of the plug and socket connectors when these are provided.

Disconnect the speedometer drive from the speedometer head.

Remove the two plug screws and loosen the steering head clip bolt and the two fork crown clamp bolts.

Unscrew the fork main tubes from the head lamp casing and the steering stem locknut from the top of the steering stem, turning each tube and the nut a turn or two at a time. When the nut has been removed from the steering stem and the main tubes have been completely unscrewed from the head lamp casing, the complete fork and wheel with steering stem can be removed.

7. Lubrication

The lubrication of the fork internal parts is effected by the oil which forms the hydraulic damping medium. All that is necessary is to keep sufficient oil in the fork to ensure that the top end of the bottom spring stud is never uncovered even in the full rebound position. The level of oil in the fork can be gauged by removing the top plug screw and inserting a long rod about $\frac{3}{8}$ " diameter. If slightly tilted this will wedge against the nut at the upper end of the bottom spring stud. If the oil is above the spring stud, it will leave a trace on the long rod, which can be seen on removal. This trace of oil implies that oil level is correct. If the fork is empty to start with, the quantity required is approximately 200ml in each leg. Recommended grade of oil is hydraulic oil or SAE 10 W 30.

WORKSHOP MANUAL BULLET

8. Steering Head Races

The steering head races are the same at the top and bottom of the head lug. They are easily removed by knocking them out with a hammer and drift and new races can be fitted either by a press or by means of a hammer and wooden drift. The steering head bearing consists of two deep groove thrust races each containing nineteen $\frac{1}{4}$ " diameter balls. The bearing is adjusted by tightening the steering stem locknut after loosening the ball head clip screw and both the fork crown clamp bolts. The head should be adjusted so that, when the front wheel is lifted clear of the ground, a light tap on the handlebar will cause the steering to swing to full lock in either direction, while at the same time there should be only the slight trace of play in the bearings.

The play can be felt by keeping a finger across the head races just below the ball head on the top ball race. Do not forget to tighten the ball head clip screw and fork crown clamp bolts. Before tightening the latter make sure that the cover tubes are located centrally round the main tubes so that the bottom tube does not rub inside the cover tube. A pair of split bushes, as shown in figure is useful to ensure centralisation of the cover tubes.

ADJUSTMENT OF HEAD BALL-RACE

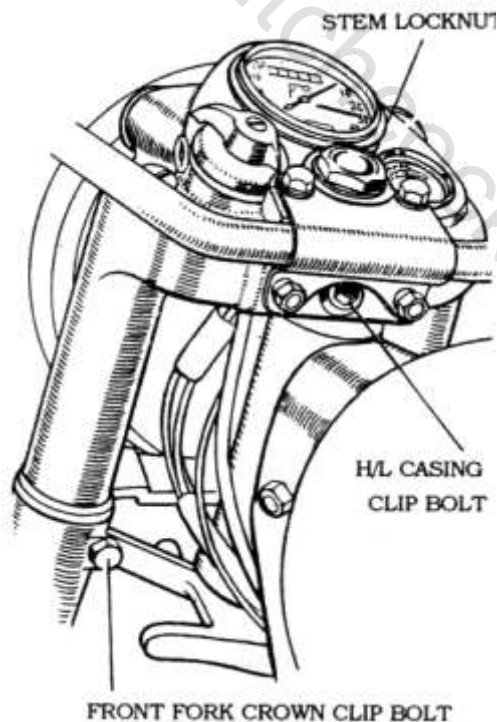

SEQUENCE FOR ADJUSTMENT

1. Loosen the Head lamp casing clip bolt by using an Allen key (Size - 5mm)
2. Loosen the front fork crown clip bolts (2 Nos.)
3. Then screw down the steering stem lock nut by $\frac{1}{2}$ to $\frac{3}{4}$ thread initially and check the play once again. If necessary further tightening can be done.

Note: Over tightening of this steering stem lock nut will result in vehicle drag.

9. Lubrication-Steering Head

The steering head races and stand pivot bearing should be well greased on assembly. No nipples are provided for the steering head as experience has shown that the provision of nipples at this point causes trouble through chafing and cutting of control and lighting cables. If the steering head bearings are well packed with grease initially they will last for several years or many thousands of kilometres.

WORKSHOP MANUAL BULLET

WHEELS

FRONT WHEEL

1. Removal from Fork

To remove the front wheel from the fork, place the machine on the centre stand with sufficient packing beneath the stand to lift the front wheel clear off the ground when vehicle is tilted back. Slacken the brake cable adjustment and disconnect the cable from the handlebar lever and from the operation cam lever on the hub.

Disconnect speedometer driving cable. Unscrew the four nuts securing the fork lug caps and allow the wheel to drop forward out of the front fork. Make sure that the machine stands securely on the rear wheel and centre stand - if necessary place a weight on the dual seat or a strut beneath the front end of engine near frame down tube to ensure this.

2. Dismantling

Lock the brake 'on', by applying the front brake, and unscrew the cover plate nut. (For front brake with twin leading shoes loosen the lock nuts on the link rod and turn link rod so that both brake shoes become free and are not in contact with the brake drum) The cover plate assembly can then be withdrawn from the brake drum.

The brake shoes can be removed after detaching the return springs. Brake linings are supplied in pairs and are of 'bonded' type hence linings cannot be separated and re-fixed with new linings.

To remove the operating cam unscrew the nut, which secures the operating lever to the splines on the cam. A sharp tap on the end of the cam spindle will now free the lever, after which the cam can be withdrawn from its housing. The brake shoe pivot pin can be removed after unscrewing the nut which secures it to the cover plate.

To remove the hub spindle and bearings, having first removed the brake cover plate, unscrew the retaining nut by holding the spindle on a benchvice with soft jaws. Remove speedo drive assembly and the felt washer from the other side of the hub. Remove the felt washer and the distance washer from the brake drum side and hit one end of the spindle with a brass or plastic mallet, thus driving it out of the hub, bringing one bearing with it and leaving the other in position in the hub. Drive the bearing off the spindle and insert the latter once more in the hub through the end from which it was removed. Now drive the spindle through the hub, the other way, which will bring out the other bearing.

3. Fitting Limits for Bearings

The fit of the bearings in the hub barrel is important. The bearings are locked on the spindle between shoulders and the distance pieces, which in turn are held by the nuts on the spindle. In order to prevent endways pre-loading of the bearings, it is essential that there is a small clearance between the inner edge of the outer race of the bearing and the back of the races in either end of the barrel. To prevent any possibility of sideways movement of the hub barrel on the bearing, it is therefore necessary for the bearings to be a tight fit in the barrel, but this fit must not be so tight as to close down the outer race of the bearing and thus overload the ball race in the bearing.

WORKSHOP MANUAL BULLET

FRONT WHEEL AND HUB ASSEMBLY - SINGLE LEAD

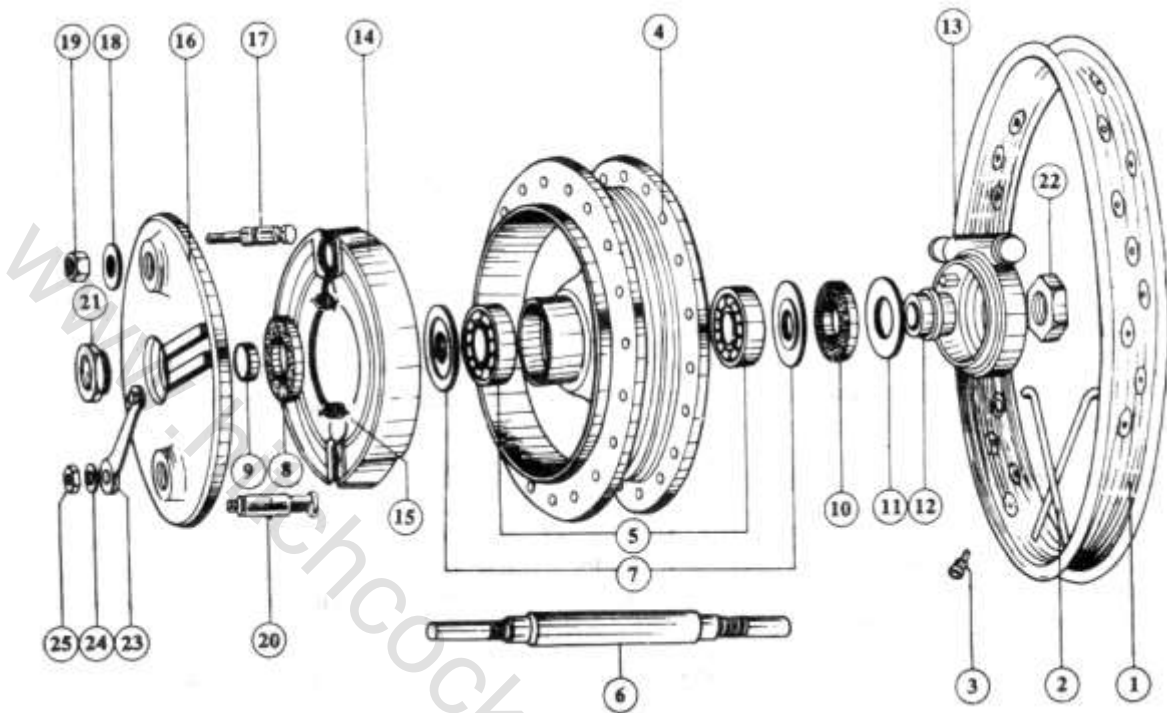

1. Front Wheel rim (WM 2-19)
2. Front Wheel spokes (outer)
3. Front Wheel spoke nipples
4. Front hub assembly (7" dia)
5. Front hub journal bearing (SKF 6203)
6. Front hub spindle
7. Front hub felt retainer
8. Front hub felt washer (drum side)
9. Front hub cover plate distance collar
10. Front hub felt washer (speedo side)
11. Front hub felt washer retainer (speedo side)
12. Front hub speedo drive spacing collar
13. Speedo drive complete
14. Front brake shoe c/w lining S/L
15. Front brake shoe spring (7" dia)
16. Front brake cover plate (7" dia.) S/L
17. Front brake shoe pin (7" dia-) S/L
18. Washer front brake shoe pin S/L
19. Nut front brake shoe pin S/L
20. Front brake operating cam (7" dia) S/L
21. Nut front hub cover plate
22. Front hub spindle nut (speedo side)
23. Front brake operating cam lever (7" dia)(S/L)
24. Washer front brake operating cam lever (S/L)
25. Nut front brake operating cam lever S/L

4. Re-assembly

To refit the bearings in the hub, two hollow drifts (Special Tool No 2011) are required. One bearing is first fitted to one end of the spindle by means of the hollow drift. The spindle and bearing are then inserted into one end of the hub barrel, which is then supported on one of the hollow drifts. The other bearing is then inserted over the upper end of the spindle and driven home by means of the second hollow drift either under a press or by means of a hammer, which will thus drive both bearings into position simultaneously.

In order to make quite sure that there is clearance between the inner faces of the outer bearing races and the bottom of the recesses in the hub, fit the distance washers, cover plate, dust excluder and the nuts on the spindle. Tightening the nuts should not have any effect on the ease with which the spindle can be rotated.

WORKSHOP MANUAL BULLET

FRONT WHEEL AND HUB ASSEMBLY - TWIN LEAD

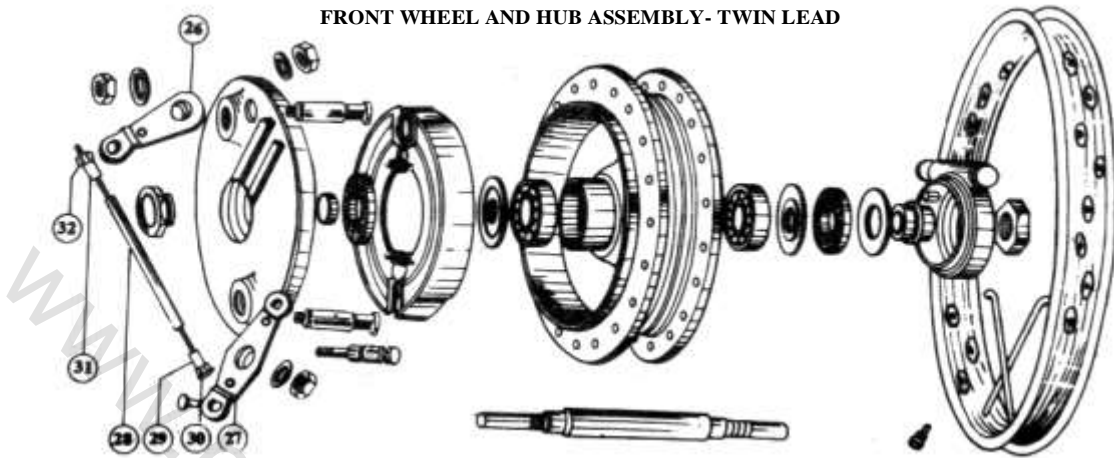

- 26. F/B operating lever (short) T/L
- 27. Front brake lever long T/L
- 28. Link Rod Ft. Brake T/L
- 29. L/Rod Trunnion (RH Thread) T/L
- 30. L/Rod Trunnion Nut (RH) T/L
- 31. L/Rod Trunnion (LH) T/L (NF)
- 32. L/Rod Trunnion Nut (LH) T/L
- 33. Front brake shoes C/W lining T/L

- 34. Front brake Cover Plate T/L
- 35. Front brake shoe pin T/L
- 36. Washer front brake shoe pin T/L
- 37. Nut front brake shoe pin T/L
- 38. Front brake operating cam
- 39. Washer, front brake operating cam
- 40. Nut front brake operating cam.

If tightening the nuts makes the spindle hard to turn, the bearings are bottoming in the recesses in the hub barrel and the inner races are not resting on the shoulder of the spindle. In this case, the bearing should be removed and a thin packing shim should be fitted between the inner race and the shoulder on the spindle.

Assemble the operating cam into cover plate after smearing grease, on the pivot pin and the cylindrical bearing surface of the operating cam. Fit the operating lever, on its splines in a position to suit the extent of wear on the linings and secure with the nut and washer. Note that the position of the operating lever may have to be corrected when adjusting the brake after refitting the wheel. The range of adjustment can be extended by moving this lever on to a different spline.

NOTE: Before replacing the felt washers which form the grease seals, pack all bearings with medium/lime soap or aluminium soap greases or multipurpose grease. The use of H.M.P. greases which have a soda soap base is not recommended, as these tend to be slightly corrosive if any dampness finds its way into the hubs.

Make sure that the inside of the brake drum is quite free from oil or grease, dampness, etc. When replacing the speedo drive, make sure that the dogs on the speedo drive are correctly engaged with the slots in the end of the hub barrel. Make sure that the speedo drive is correctly positioned, so that the speedo cable would not be too stretched or will not have any sharp bends. Replace the felt washers, distance collars, and brake cover plate and securely tighten the spindle nuts.

WORKSHOP MANUAL BULLET

REAR WHEEL

1. Removal of wheel – quickly-detachable type

The rear wheel is quickly detachable without disturbing the sprocket. Place vehicle on centre stand. Remove the split pin and the castle nut securing the long spindle which is located on the sprocket side. Slide out the long spindle from the wheel and remove both the spacers from the RH side fork end. Tilt the vehicle and slide out the wheel from the chainstay. For assembly reverse the process but take care to engage the cush rubbers properly on the driving lugs.

2. Cush Drive

Four rubber blocks are fitted in the pockets of centre hub and four radial vanes are formed on the back of the rear sprocket/brake drum, thus transmitting both driving and braking torque and smoothing out harshness and irregularity in the former.

If the cush drive rubbers are worn, and the amount of free movement measured at the tyre exceeds 1/2" to 1", the rubbers should be replaced. The condition of the cush drive rubber in the rear wheel can be gauged by placing the machine on the rear stand, applying the rear brake and rotating the rear wheel.

The cush rubbers are fixed in the pockets of centre hub by means of buttons provided in the rubber blocks, thus the rubbers are prevented from falling down when wheel is removed or refitted.

RE-ASSEMBLY OF CUSH DRIVE

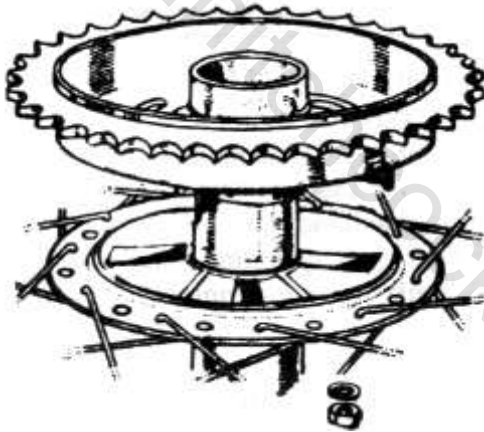

3. Removal and re-assembly of rear wheel sprocket

Removal of sprocket is necessary only if replacement of sprocket or attention to brakes is required. Remove the wheel as described above. Remove the brake rod nut and disconnect the brake rod from the operating lever. Be sure to 'DISCONNECT' the stop light switch from the link, otherwise the switch will get damaged. Remove the securing bolts of the chainguard at both front and rear ends and remove the chain guard. Disconnect the chain link. Remove the securing nuts from brake anchor and wheel spindle. Unwrap the chain from the rear sprocket. Slide out the rear sprocket assembly from the chainstay.

For re-assembly proceed in the reverse order. Make sure that the inside of the brake drum is quite free from oil grease dampness etc. Ensure the chain lock clip is fitted in the right direction so that the closed end of the clip is towards the direction of motion. The rear chain should be inspected for wear before assembly. It should be renewed when its length has increased by 1.1/8" than a new chain. The rear chain can be adjusted by slackening the wheel spindle nuts and brake anchor shoe pin nut and turning the notched cam plate.

WORKSHOP MANUAL BULLET

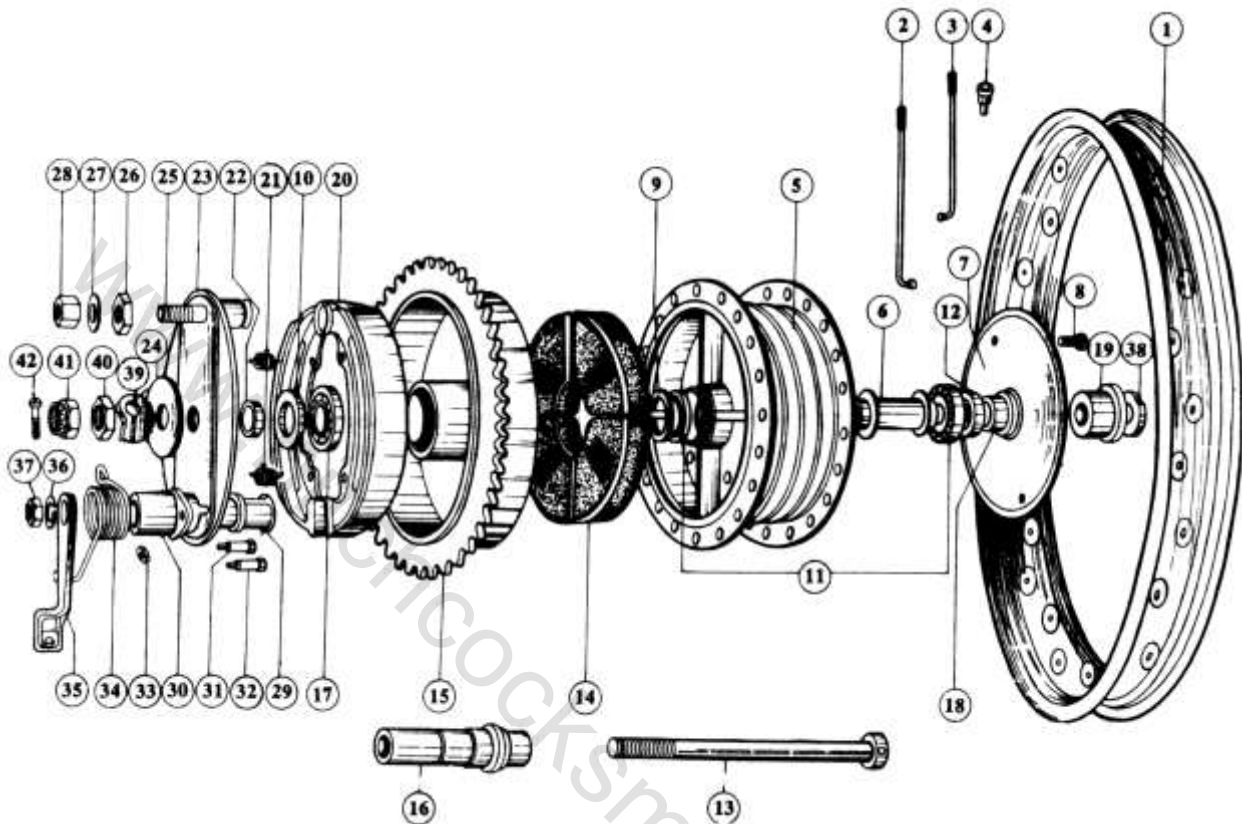

REAR WHEEL AND HUB ASSEMBLY

1. Rear wheel rim WM 2-19
2. Rear wheel spokes (dust cover side-outer)
3. Rear wheel spokes (dust cover side-inner)
4. Rear wheel spoke nipples
5. Centre hub with barrel
6. Rear hub bearing spacer assy.
7. Rear hub dust cover
8. Rear hub dust cover screw
9. Rear hub barrel '0' ring
10. Rear hub grease seal (small)
11. Rear hub journal bearing
12. Rear hub grease seal (small)
13. Rear hub spindle (long)
14. Rear hub sprocket cush rubber
15. Rear hub sprocket 38T
16. Rear hub spindle (throttle)
17. Rear hub bearing (large)
18. Distance collar (dust cover inner side)
19. Rear hub distance collar (dust cover outer side)
20. Rear brake shoe c/w lining (bonded)
21. Rear brake shoe spring
22. Rear brake cover plate distance collar
23. Rear brake cover plate assembly
24. Rear hub distance collar (drum side)
25. Rear brake shoe pin
26. Nut rear brake shoe pin
27. Washer rear brake shoe pin (plain)
28. Shoe pin nut rear brake anchor
29. Rear brake operating cam
30. Rear brake cam bush
31. Rear brake operating cam bush pin (long)
32. Rear brake operating cam bush pin (short)
33. Rear brake operating cam bush pin locknut
34. Rear brake return spring
35. Rear brake operating cam lever assy
36. Washer rear brake lever
37. Nut rear brake lever
38. Rear hub adjuster (RH)
39. Rear hub adjuster (LH)
40. Locknut (Rear hub spindle)
41. Nut rear hub spindle
42. Rear hub spindle split pin

WORKSHOP MANUAL BULLET

4. Dismantling the Rear Brake Shoes.

After separating the cover plate from sprocket assy, unscrew the brake shoe pivot pin lock nut and the operating lever nut. The assembly of brake shoes, return springs, pivot pin and operating cam can be removed from the cover plate by unscrewing the pivot pin and applying light blows with a hammer and drift on the end of the operating cam. The return spring can then be unhooked from the brake shoes.

Brake linings are supplied in pairs and are of bonded type hence linings cannot be separated and refixed with new linings.

5. Removal of bearing from centre hub and re-assembly

The bearing from the centre hub can be removed by inserting a small rod of 6mm dia. Insert the rod through the bearing at one end and through the slit provided, at the ends of the bearing distance tube. Hit the rod with a small mallet on radially opposite sides of the bearing. The other bearing also can be removed by hitting it from opposite side after the removal of grease seal.

To remove the hub spindle (short) and bearings from the brake drum, having already removed the brake cover plate assy., hit outer end of the spindle with a brass hammer or mallet thus driving it out of the bearing. Now the grease seal and the bearing from the brake drum can be removed one after the other.

The fit of the bearings in the hub barrel is important as in the case of front wheel.

To fit the bearings in the hub, use the two hollow drifts proceed as follows. In order to make sure that there is clearance between the inner faces of the bearings and the bottom of the recess, first fit the sealed bearing at the cush drive side of the centre hub so that the bearing will sit in the housing flush with the boss face. Then place the distance tube from other end and press the second bearing and also the grease seal. (small)

NOTE: Before replacing the bearings in the centre hub as well as sprocket brake drum, pack with medium/heavy lime soap or aluminium soap grease. The use of HMP grease which have soda soap base is not recommended as these tend to be slightly corrosive if any dampness finds its way into the hub.

6. Re-assembly of brake shoes

Make sure that the brake shoe pivot pin is really tight in the cover plate and smear grease in the grooves of the pivot pin and on the operating face of the cam. Also smear grease on the cylindrical

OPERATION OF A SINGLE LEAD SHOE - DRUM BRAKE

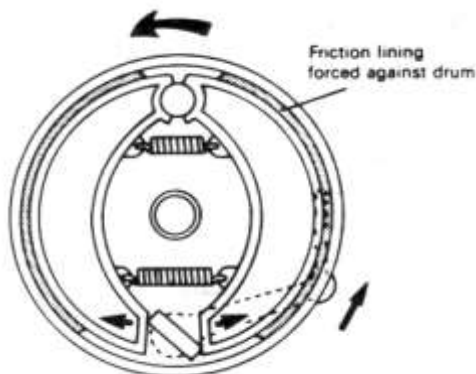

OPERATION OF A TWIN LEAD SHOE - DRUM BRAKE

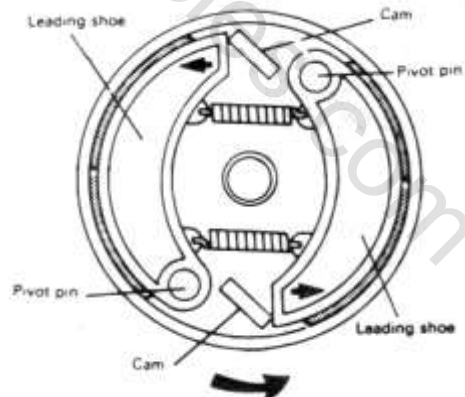

WORKSHOP MANUAL BULLET

bearing surface of the operating cam, if this has been removed. Fit the operating lever on its splines in a position to suit the extent of wear on the linings and secure with the nut. The range of adjustment can be extended by moving the lever on to a different spline.

Note that the bolt holes in the cover plate for locating the rear brake cam bush are slotted, to enable the brake shoe assy, to be centered in the drum. The brake cover plate assy with the shoes should be fitted over the spindle into the brake drum and the brake applied as hard as possible by means of the operating lever. This will centre the shoes in the drum. The brake cover plate assembly should then be removed and the screws should then be tightened fully and secured with the lock nuts. If the shoes are not correctly centred, the brake will be either ineffective or too fierce, depending on whether the trailing or leading shoe first makes contact with the drum. With the brake assy, correctly centered and screws securing the cam housing correctly tightened wear on both linings should be approx equal.

DRIVE CHAIN ADJUSTMENT

7. Adjustment of Drive Chain

Check slackness of the drive chain every 1000 Kms. and adjust if necessary. The frequency of adjustment depends entirely on the rider habits and usage conditions. If the chain is adjusted too loose or too tight, the chain may either jump off the sprocket or might break, causing serious damage to vehicle/engine parts and may also lead to a serious accident.

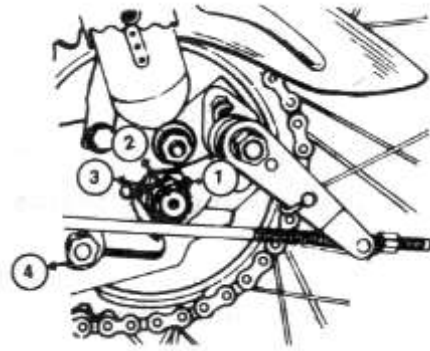

The Procedure for Adjusting the rear chain is as follows;

Place the vehicle on its centre stand on a firm flat surface. Unfold and remove the split pin (1) on the castle nut on LH side of rear wheel. Loosen the castle nut (2). Loosen the stub axle nut (3) and rear brake anchor pin nut (4). Move the cam adjusters to the same number of notches on either side of the axle. Rotate the rear wheel and check the chain tension on the top run of the chain. The minimum free play of the chain should be 25 to 30 mm with the vehicle on its centre stand. Check the wheel alignment of front and rear wheel, using a straight edge or by means of stretching a rope from the front wheel to rear wheel. Retighten the stub axle nut. Rotate the rear wheel, apply the rear brake hard and hold the rear brake pedal firmly in the depressed position so that the brake assembly is centralised in the brake drum. Retighten the brake anchor pin nut. Release the brake pedal. Ensure that the chain adjuster on the RH side is butting against the peg on the chain stay and is not disturbed from its adjusted position. Retighten the castle nut fully such that the split pin hole is aligned. Locate the split pin in position and bend out the split ends. Check the chain tension again at 3 or 4 places by rotating the wheel and ensure the free play is 25 to 30 mm on the top run.

8. Wheel Alignment

NOTE: It is not possible to guarantee that the wheels are correctly aligned when the same notch position is used on both adjuster cams. It is therefore not sufficient to count the notches and use the same position on both sides of the machine. The only way to guarantee that the wheels are in line is to check the alignment from front wheel to back using either a straight edge or a piece of taut string. The alignment should be checked on both sides of the machine.

WORKSHOP MANUAL BULLET

It is usual to check the alignment of the wheels at a point about six inches above the ground. If the alignment is checked also towards the top of the wheels, it will be possible to ascertain whether or not the frame is twisted so as to cause one wheel to be leaning while the other is vertical. To do that it is always necessary to remove the mudguards and unless a straight edge cut away in its centre portion is available, it will be necessary also to remove the cylinder, tool boxes, battery etc., in order to allow straight edge or a piece of taut string to contact the front and rear tyres.

In the later models a punch mark is provided on both the chain adjusters. These punch marks can be used as reference marks and the chain adjusters must be moved by the same number of notches from this punch mark to ensure proper wheel alignment.

9. General

1. Wheel Rims

The rim fitted to the wheel is WM 2-19" pierced with 40 holes for locating the spoke nipples.

2. Spokes

The spokes are of plain type 4mm dia with 90 degree counter sunk heads, angle of bend 80 to 95 degree. Thread diameter is 4.4mm x 0.7 pitch thread. Spoke lengths are 170mm for the rear wheel and 165mm for the front wheel.

3. Wheel Building and Truing

The spokes are laced in such a way that wheel must be built centrally in relation to the outer faces of the distance collars which fit between the fork ends. The rim should be trued as accurately as possible, the maximum permissible run-out both sideways and radially being plus or minus 1/32".

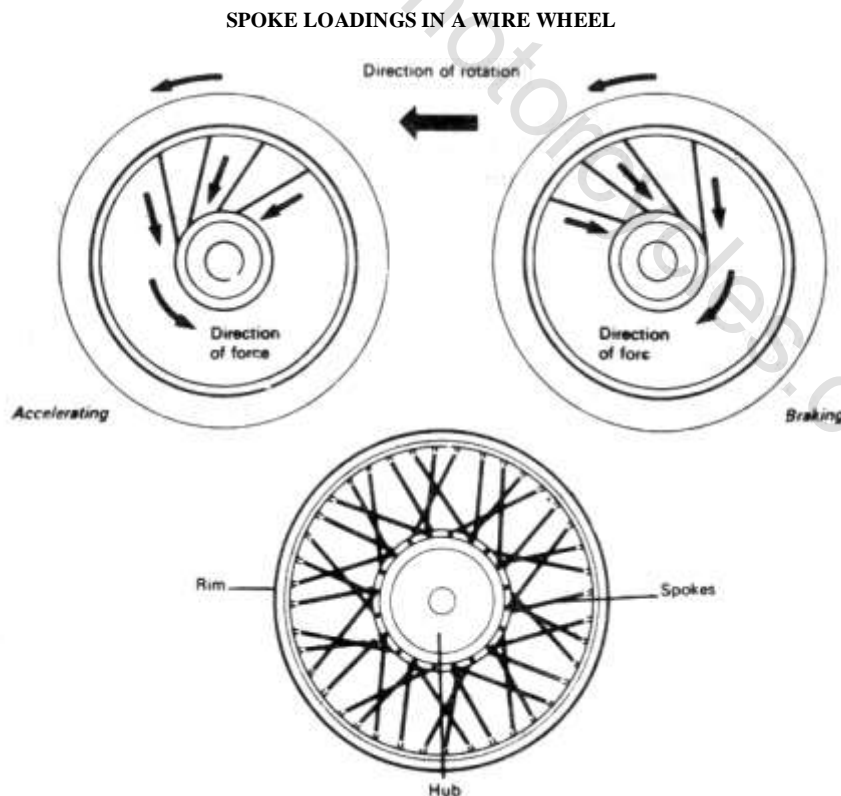

WORKSHOP MANUAL BULLET

The key to correct lacing is the inside and outside spokes from the flange must slope down in the opposite direction as in the figure. The spokes are in opposite direction to the inner two spokes. In the group of four spokes laced, the inner spokes of each flange are sloping down in the opposite direction of the outer two spokes of the next grouping of four spokes and so on.

4. Lubrication

Front and rear wheel bearings are lubricated by packing them with grease every 10,000 Kms. after dismantling the hub and requires no further attention

5. Tyres

Standard tyres are of size 3.25-19" for Front & 3.50-19" for Rear.

When removing the tyre always start close to the valve and see that the edge of the cover at the other side of the wheel pushed down into the well.

If the correct method of fitting and removal of the tyre is adopted it will be found that the covers can be manipulated quite easily with the small tyre levers. The use of long levers and or excessive force is liable to damage the walls of the tyre. After inflation make sure that the tyre is fitting evenly all the way round the rim. A line moulded on the wall of the tyre indicates whether or not the tyre is correctly fitted.

Please refer the attached diagrams in page No.59 for correct procedure for removal and refitting of tyres.

WORKSHOP MANUAL BULLET

ADJUSTMENT OF BRAKES

1. Front Brake Twinleading Arrangement - Bullet 350/500 CC

All Bullet 350 & 500 cc models are fitted with twin leading front brakes for effective braking. These are with bonded type brake shoes of 7" diameter.

Where brake judder or sponginess is experienced and the cause is narrowed down to uneven braking of the front wheel, the procedure to adjust the same is as follows:

TWIN LEADING BRAKE ARRANGEMENT

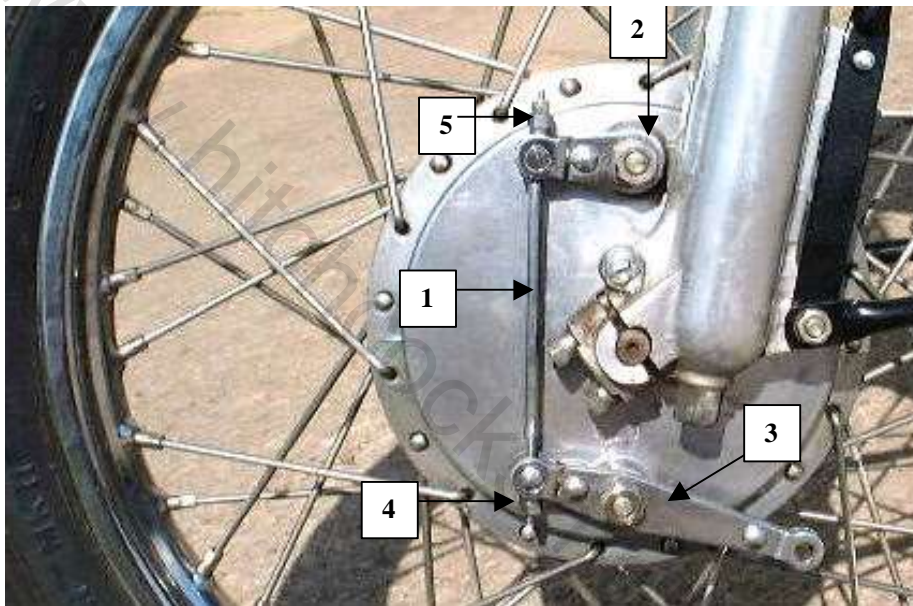

1. Link rod
2. F/B Operating Lever (Short)
3. F/B Operating Lever (Long)
4. L/Rod Trunnion Nut (RH)
5. L/Rod Trunnion Nut (LH)

2. Procedure For Adjustment of Brakes

2.1 Front wheel removed from the vehicle

Hold the front wheel spindle in a benchvice with soft jaws to avoid damage to spindle. Remove the brake cover plate by loosening the nut and clean the brake drum and brake shoe assembly.

Mark four or five lines with a chalk across the shoe lining surfaces and assemble the cover plate to the wheel and clamp it firmly with the nut. Hold the brake cam levers so that the brake shoes are binding lightly on to the drum and rotate the wheel in the normal direction of rotation (anticlock wise direction looking from brake drum end). Remove the brake cover plate and observe the marks on the brake shoe surfaces. If the contacts are uniform, the marks on the shoes would have been erased uniformly. If the mark on one side is not erased, it indicates that the brake shoe has to be moved towards the drum through adjustment provided. For example: if the shoe bearing on the cam connected to the short lever has the chalk marks intact then the shoe should be moved outwards towards the drum. For this adjustment, refit the cover plate assembly, hold the longer brake lever pulled fully in the operating direction so that the brake shoe is binding on the drum and proceed as follows:

NOTE: Check the locknuts for threading - RH or LH.

Loosen the locknuts provided at both the ends of link rod and rotate the link rod clockwise so as to move the short lever more towards the normal direction of the operation i.e. towards the loner lever.

WORKSHOP MANUAL BULLET

Stop adjusting when the shoe has moved and touches the brake drum which can be felt while making the adjustment through the link rod. Then lock the two lock nuts provided at the end of link rod. If the marks on the shoe operated by the longer lever are not erased, carry out above adjustments in the reverse manner (anticlockwise) ensuring that both the brake shoes are in contact with the drum uniformly.

CAUTION: Do not attempt to rotate the link rod without loosening the locknuts and do not overtighten the lock nuts on the link rod. The link rod threads might snap if either of the above is done.

2.2. Without Removing Front Wheel From Vehicle

Increase cable play by threading in the adjuster either at handle bar end or at fork bottom tube end. Loosen the link rod lock nuts sufficiently at the top and bottom (L & R threads).

Apply front brake and hold the lever (Do not release the brake till the adjustment is complete). This would ensure that the brake shoe nearest to the drum would be in contact with the brake drum.

Turn the link rod right to left (clockwise) or in the opposite direction simultaneously checking whether the short lever moves towards the long lever or vice versa.

Turning the link rod would be easy till the other shoe also comes in contact with the brake drum and thereafter resistance would be felt and would be difficult to rotate further.

Release the hand lever and check for free rotation of the front wheel (No brake binding should be felt and wheel should rotate free).

Hold link rod in position and tighten lock nuts just sufficiently. Adjust the brake cable adjusters such that brake lever travel is 20 to 30 mm from its resting position.

NOTE: 1. The link rod is provided with the LH and RH thread for the above adjustments. Hence the correct trunnions and lock nuts are to be used at the respective threaded ends. (Refer Diagram)

2. Link rod adjustment can be made to compensate for the lining wear in the normal service life which avoids repositioning of the levers.

3. Any excessive play in the brake cable can be corrected by using the adjuster provided in the front brake lever end at the handle bar and through the adjuster provided on the left hand fork bottom tube assembly.

CAUTION: 1. If you are in doubt, please contact the authorised dealer/distributor for their guidance and for correct adjustment of the front brakes.

2. Any mal-adjustment of the brake system will render the brakes ineffective and will affect the safety of the rider.

2.3. Rear Brake

Set brake pedal resting position with respect to the foot rest by adjusting the stop bolt provided on the left side on the main frame.

Turn the adjusting nut on the brake rod, clock wise to reduce pedal travel and vice versa to increase pedal travel.

The recommended travel is 20 to 30mm. Rotate rear wheel and check for free rotation and ensure no brake binding occurs.

WORKSHOP MANUAL BULLET

TYRES - REMOVAL AND REPLACEMENT

1. At some time or other the need will arise to remove and replace the tyres, either as a result of a puncture or because renewal is required to offset wear. To the inexperienced, tyre changing represents a formidable task, yet if a few simple rules are observed and the technique learned the whole operation is surprisingly simple.
2. To remove the tyre from either wheel, first detach the wheel from the machine. Deflate the tyre by removing the valve insert and when it is fully deflated push the beading of the tyre away from the wheel rim on both sides so that the beading enters the centre well of the rim. Remove the locking cap and push the tyre valve into the tyre.
3. Insert two tyre levers close to the valve, on either side of the valves and lever the edge of the tyre over the outside of the wheel rim. Very little force should be necessary; if resistance is encountered it is probably due to the fact that the tyre beading have not come off the wheel rim all around the tyre.
4. Once the tyre has been edged over the wheel rim, it is easy to work around the wheel rim so that the tyre is completely free on one side. At this stage, the inner tube can be removed.
5. Working from the other side of the wheel, ease the other edge of the tyre over the wheel rim. Continue to work around the rim until tyre is free completely from the rim.
6. If a puncture has necessitated the removal of the tyre, reinflate the inner tube and immerse it in water to trace the source of the leak. Mark its position and deflate the tube. Dry the tube and clean the area around the puncture with a petrol soaked rag. When the surface has dried, apply rubber solution and allow this to dry before removing the protective sticker from a patch and applying the patch to the surface.
7. It is best to use a patch of the self-vulcanising type, which will form a very permanent repair. Note that it may be necessary to remove another protective covering from the top surface of the patch, after it has sealed in position. Inner tubes made from synthetic rubber may require a special type of patch and adhesive if a satisfactory bond is to be achieved.
8. Before replacing the tyre, check the inside of it to remove the foreign particle which caused the puncture. Check the outside of the tyre, particularly the tread area, to make sure nothing is trapped that may cause a further puncture.
9. If the inner tube has been patched on a number of past occasions, or if there is tear or large hole, it is preferable to discard it and fit a new tube.
10. To replace the tyre, inflate the inner tube just sufficiently for it to assume a circular shape. Then push it into the tyre so that it is enclosed completely. Lay the tyre on the wheel at an angle and insert the valve through the rim tape and the hole in the wheel rim. Attach the locking cap on the first few threads, sufficient to hold the valve captive in its correct location.
11. Starting at the point furthest away from the valve, push the tyre beading over the edge of the wheel rim until it is located in the central well. Continue to work around the tyre in the fashion until the whole of one side of the tyre is on the rim. It may be necessary to use a tyre lever during the final stages.

WORKSHOP MANUAL BULLET



Tyre removal: Deflate inner tube and insert lever in close proximity to tyre valve.

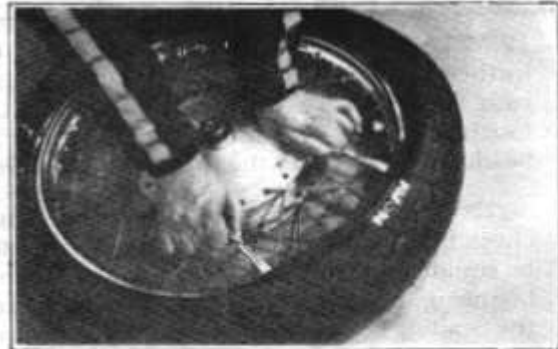

Use two levers to work bead over the edge of rim.



When first bead is clear, remove tyre as shown.



Tyre fitting: Inflate inner tube and insert in tyre



Lay tyre on rim and feed through hole in rim.

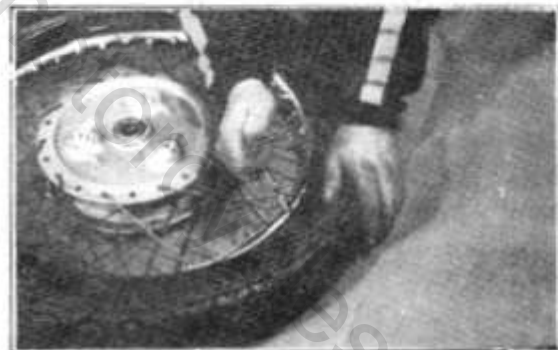

Work first bead over rim. Using lever in final section.



Use similar technique for second bead, finish at tyre valve position.



Push valve and tube up into tyre when fitting final section, to avoid trapping.

WORKSHOP MANUAL BULLET

12. Make sure that there is no pull on the tyre valve and again commencing with the area furthest from the valve, ease the other beading of the tyre over the edge of the rim. Finish with the area close to the valve, pushing the valve up into the tyre until the locking cap touches the rim. This will ensure the inner tube is not trapped, when the last section of the beading is edged over the rim with a tyre lever.

13. Check that the inner tube is not trapped at any point. Reinflate the inner tube, and check that the tyre is seated correctly around the wall of the tyre on both sides, which should be equidistant from the wheel rim at all points. If the tyre is unevenly located on the rim, try bouncing the wheel when the tyre is at the recommended pressure. It is probable that one of the beading has not pulled clear of the centre well.

14. Always run the tyres at the recommended pressures and never under or over-inflate. See specifications for recommended pressures.

15. Tyre replacement is aided by dusting the side walls, particularly in the vicinity of the beading with a liberal coating of French chalk.

16. Never replace the inner tube and tyre without the rim tape in position. If this precaution is overlooked there is a good chance of the ends of the spoke nipples chafing the inner tube and causing a series of punctures.

17. Never fit a tyre which has a damaged tread or side walls. Apart from the legal aspects there is a very great risk of a blow-out, which can have serious consequences on any two wheel vehicle.

18. Tyre valves rarely give trouble but it is always advisable to check whether the valve itself is leaking before removing the tyre. Do not forget to fit the dust cap which forms an effective second seal. This is especially important on a high performance machine, where centrifugal force can cause the valve insert to retract and the tyre to deflate without warning.

CAUTION: Sudden deflation may cause an accident, particularly if it occurs in the front wheel.

WORKSHOP MANUAL BULLET

IGNITION AND LIGHTING SYSTEM

1. General

The A.C., Lighting and Ignition system comprises of seven main components:

(i) Alternator (stator & rotor). (ii) Regulator and Rectifier (RR Unit) (iii) Ignition coil, (iv) Contact breaker unit with automatic timing control, (v) Lighting switch, (vi) Ignition switch, (vii) 12V. Battery.

When the engine is started, the alternator generates AC energy which passes through the rectifier as DC energy. This rectified DC gets regulated by the regulator and charges the battery depending on battery and load conditions.

2. Alternator

The alternator comprises of two main components, a stator and a rotor. The stator carries three pairs of series-connected coils. The rotor is a permanent magnet. The stator and rotor can be separated without the need to fit magnetic keepers to the rotor poles.

As the rotor turns, paid and repeated reversals of flux take place in the coil cores. These lines cut through the turns of the coil and induce alternating voltages in that coil. External connections are taken from these coils to a regulator rectifier.

3. Regulator-Rectifier unit

The alternator which consists of stator and rotor has three pairs of series connected coils.

The alternator output is directly connected to regulator rectifier AC input terminals.

The control circuit of regulator rectifier unit monitors the battery voltage and regulates the charging current to the battery according to pre-set regulating range (Range: old: 13.8 volts to 14.6 volts. New: maximum of 15.5 volts)

During the day running period ie: ignition load alone, the battery voltage rises rapidly and the regulator starts regulating the charging current to the battery.

When the head light is switched 'ON' more current is drawn from the battery and the regulator in turn allows higher current to flow into the battery for charging.

RECTIFIER CUM REGULATOR

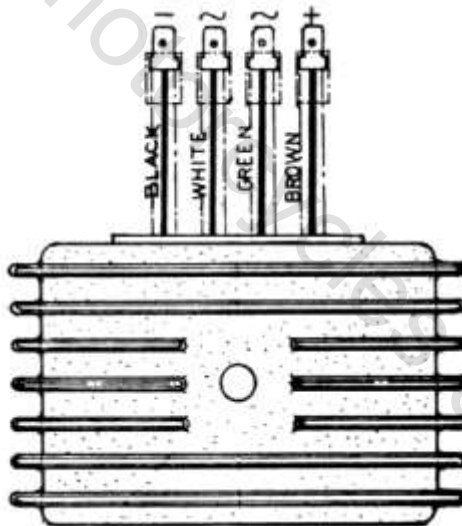

WORKSHOP MANUAL BULLET

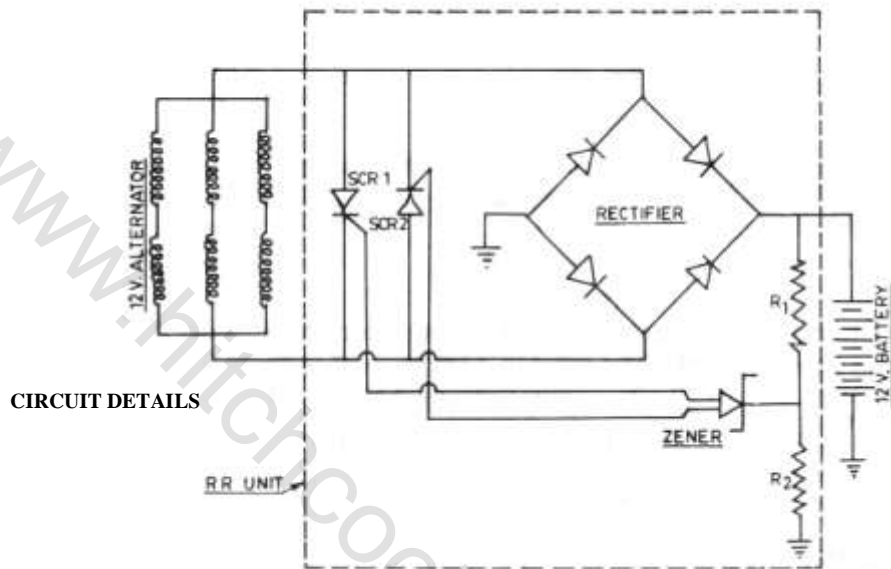

4. New type Regulator - Rectifier. (on Vehicles produced after July 1995)

This is an improved version of the previous regulator cum rectifier.

It is mounted under the dual seat.

The input and output connections are the same as in the old unit.

Salient feature:

The modified regulator, rectifier has the advantage that in the event of the regulator failing and the ammeter not indicating charge, the regulator can be disconnected from the circuit and charging will take place without any regulation of current.

Also the regulator or the rectifier can be replaced individually in the event of a failure.

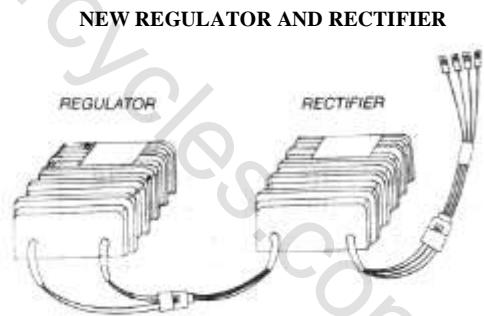

CAUTION: In case the regulator is faulty and has been disconnected from the circuit, it should be replaced through the nearest authorised Enfield dealer to prevent over charging of the battery and subsequent damage to the battery and other electrical systems.

WORKSHOP MANUAL BULLET

5. Mounting arrangement of new regulator - rectifier Unit.

1. Remove 4 wire connections from regulator cum rectifier which is mounted on the fixed mudguard of the vehicle (just below the ignition coil)
2. Remove the dual seat mounting and dual seat.
3. Fix the new strip plate (assembled with rectifier/ regulator / flasher unit) on to the front mounting studs of the seat.
4. Connect the rectifier wires to the main cable harness. Connect like colour wires together.
5. Connect the flasher unit wire.
6. Reassemble the dual seat over the strip and tighten.

MOUNTING ARRANGEMENT OF NEW REGULATOR - RECTIFIER

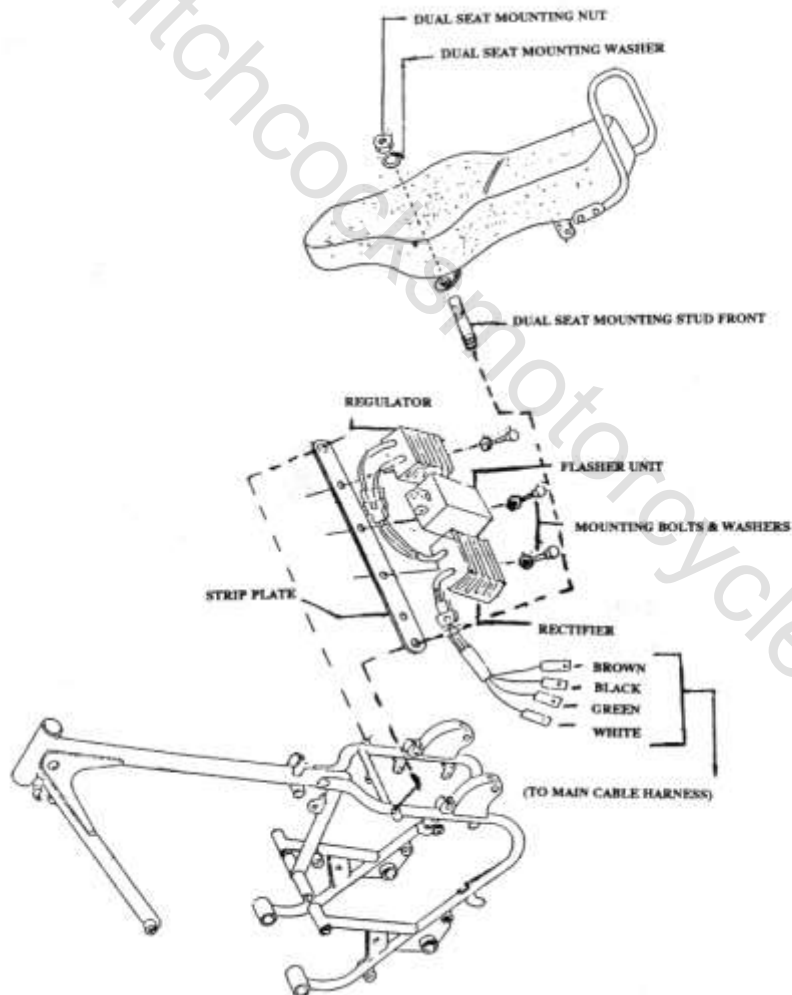

WORKSHOP MANUAL BULLET

6. Routine Maintenance

The alternator and regulator rectifier requires no maintenance apart from ensuring that all connections are clean and tight.

If the rotor, stator, engine crankshaft or rear half of the chaincase have been disturbed, the airgap between the rotor and stator should be checked for a minimum of 0.006" gap.

The ignition coil is located beneath the seat. It should be kept clean and the terminals kept tight. When the high tension cable shows signs of perishing or cracking it must be renewed.

7. Contact Breaker Unit/Contact Set

The contact breaker setting should be checked after the first 800 Kms. running and subsequently every 5,000 Kms. (3000 miles)

Cleaning contact breaker points

Remove the contact breaker cover and examine the contacts. If they are dirty or pitted, they must be cleaned by polishing with a fine carborandum stone or very fine emery cloth. Afterwards wipe away any dirt or metal dust with a petrol moistened cloth.

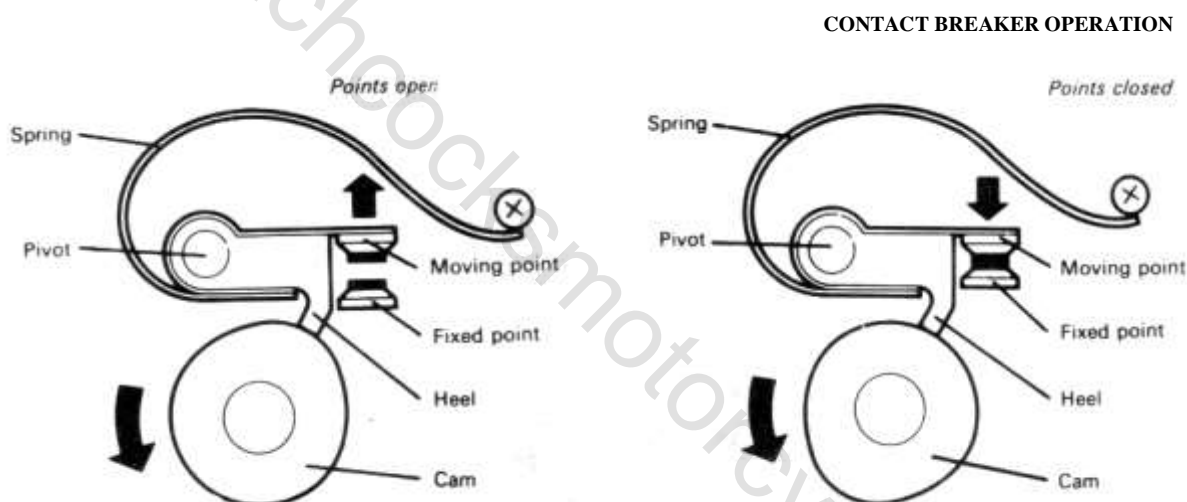

Setting contact breaker gap.

To check or reset the gap, turn the engine over slowly until the piston is at TDC on compression stroke and the contacts are seen to be fully open. Insert 0.35 to 0.40mm (0.014" - 0.16") feeler gauge between the contacts. Slacken the screw 'A' securing the fixed contact plate and adjust the position of the plate until the gap is the thickness of the feeler gauge and tighten. If the gap is correct, the gauge will be a sliding fit.

Setting ignition timing.

To check or reset the ignition timing, rotate the crankshaft in the normal direction until the piston is just before TDC and the contact breaker points just commence to open. (The best way to check the opening of points is to switch on the ignition and crank the engine slowly until the ammeter needle just returns to its central position. The points should just commence to open at this position. Check the position of the piston which should now be 0.8mm before TDC on the compression stroke. At this position slacken the two screws B. Swing the base plate to the left to advance or to the right to retard the ignition.

WORKSHOP MANUAL BULLET

Retighten the two screws such that the CB points gap just commences to open. To check whether the adjustment is correct, insert a thin strip of tissue paper between the points and gently pull out the paper which should not get damaged and should be sliding fit.

The most accurate method of setting timing is by using a dial gauge. Remove spark plug and fix a dial gauge on the spark plug hole using a suitable adaptor. Crank engine gently so that piston is at TDC on compression stroke. With the piston at TDC rotate the dial such that the needle aligns with zero on the dial gauge.



Set the C.B. point gap at 0.35 to 0.4mm and rotate the crank shaft in the opposite direction such that the piston will be 0.8mm before TDC (This can be measured on the dial gauge). Now reset the base plate so that the points just commences to open. This can be checked by connecting a 12v bulb and the CB point in series with a battery. When the points are in contact the bulb will glow and when they just open the bulb will not glow

Lubrication (every 5,000 Kms.)

Smear the surface of the cam very tightly with mobile grease No.2, non creep oil or clean engine oil. Apply a drop of clean engine oil on the contact breaker pivot. Make sure no grease or oil gets in between the contact points.

8. Automatic Timing Control

The automatic timing mechanism provided in the contact breaker housing helps in automatically advancing the ignition timing with relation to engine speed at higher RPM.

WORKSHOP MANUAL BULLET

When servicing the CB points the cam should be checked for free movement in the clockwise direction and that it is not stuck. To obtain access to the unit, remove contact breaker cover and the base plate assembly. Apply a drop of clean engine oil on the flyweight pivots and the spring eyelets.

AUTOMATIC TIMING UNIT (ATU) OPERATION

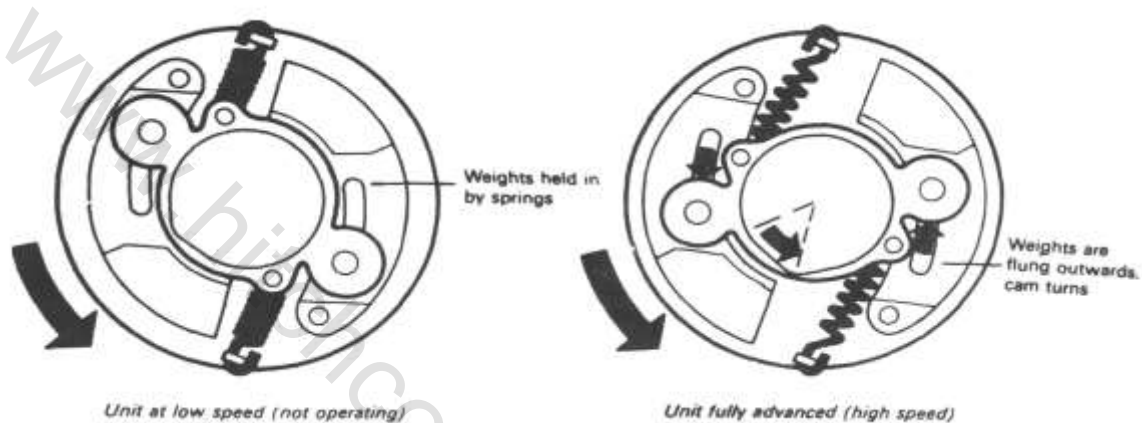

9. Spark Plug

Owing to electrode burning, the electrode gap widens in operation and may impair the performance and economy of the motorcycle. Therefore, the electrode should be cleaned and adjusted to its specified gap i.e. 0.46 to 0.50 mm. Check the electrode gap even 5,000 Km. and clean and adjust if necessary

<u>Spark Plug</u>	<u>Type</u>	<u>Ref. No.</u>
350cc -	NKG	B7HS
500cc -	NGK	B8ES

10. Battery

The battery is a 12 Volt. 5 or 5.5 amp hour capacity battery. Every week the filler cap of each cell should be unscrewed so that distilled water can be added to bring the acid level above the top of the separators if found low. (For US/ Canada battery used is 12V 7 AH)

DO NOT add tap water as this contains impurities. Acid should not be added unless this is accidentally spilled out of the battery. In case of spillage, it should be replaced by dilute sulphuric acid of the same specific gravity as in the cells. Keep the battery terminals clean, and free from corrosion by coating with pure vaseline (not grease). Many lighting troubles can be traced to unseen corrosion between the battery leads and the terminals in the battery. The corrosion takes place much more frequently at the battery terminals than at other electrical contacts.

The state of charge of the battery is indicated by the specific gravity of its electrolyte. If specific gravity falls to 1.110, the battery must be recharged using an external D.C. supply at the normal recharge rate of 0.5 Amp.

NOTE: If the battery is subjected to long periods of night parking with the lights on, it may be necessary to recharge the battery before using the motorcycle.

WORKSHOP MANUAL BULLET

11. Head Lamp

A) Regular and UK Models

The unit consists of a reflector and front lens assembly which are permanently stuck together to prevent water and dust from entering inside and spoiling the reflector.

A pefocus bulb is used, hence no focusing device is required to be fitted. The bulb has a large flange and cap. A slot in the flange helps in correctly positioning the bulb in the reflector. A spring loaded bulb holder, when assembled on the reflector ensures the bulb is held in position.

The bulb is connected to the wiring harness with the help of lucar connectors. The bulb is 12 V 40/45 watts.

To replace the bulb in the light unit, loosen the top screw on the fixing rim and remove the front rim and light assembly taking care to disengage the lug at the bottom of the front rim from the fixing rim. Disconnect the lucar connectors from the bulb terminals. Gently press and twist the bulb holder in the anticlockwise direction to remove the bulb holder. Remove the bulb out of the reflector.

Reassembly of the headlight bulb is the reverse order of the procedure mentioned above but care should be taken to locate the bulb and holder correctly in the reflector.

In the event of damage to either the lens or the reflector a new light unit must be fixed.

To remove the light unit from the front rim, remove the securing spring clips holding the light unit to the rim and remove the light unit from the rim.

While reassembling the light unit ensure the word 'top' on the lens is towards the top of the rim and secure the spring clips in the fixing rim ensuring that they are equally spaced around the rim.

B) US/Canada Models

These models are fitted with an aiming device to meet the regulations in US and Canada.

The light unit is a sealed beam. In the event of the head light bulb fusing the complete sealed beam needs to be replaced.

The dismantling of the head light assembly in the same except that the sealed beam is located in the aiming device housing. The sealed beam is located on a spring loaded screw on one side and by means of 2 springs connected to the housing.

12. Parking Lights

Access to the parking bulbs is obtained by removing the parking lamp rim (see fig.) This forces over the edge of the rubber lamp body and is additionally secured by means of a small fixing screw. After removal of the lamp rim the parking lamp lens can be pulled out of the rubber body, after which the bulb will be accessible.

Bulb - Parking Lamp - 12V - 2W

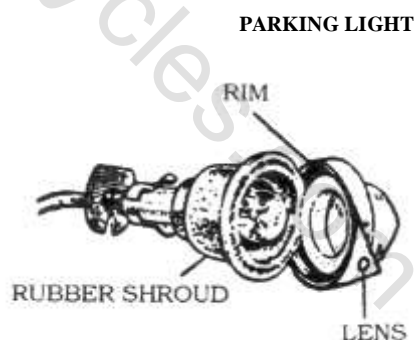

WORKSHOP MANUAL BULLET

13. Stop and Tail Lamp

The rear lamp is a combined stop and tail light and also incorporates a reflector.

Access to the bulb is obtained by removing the two screws which secure the plastic cover.

The correct bulb is 12 volt 6/18 Watt or 5/21 Watt. The 6 Watt filament provides the normal tail light, while the 18 Watt filament is illuminated by movement of the brake pedal and while operating the front brake lever.

Care must be taken while replacing a new tail light assy so that the leads to the stop tail lamp are correctly connected, as the use of the 18 Watt filament on the normal tail light will not only discharge the battery but could cause excessive heat affecting the plastic cover. At the same time, the 6 Watt filament, if used as stop light, will be ineffective in bright sunlight or at night when the tail light filament is illuminated.

14 Horn

The machine is fitted with a 12V x 3 Amps D.C. Horn. This is a sealed unit and should never be tampered with. A screw is provided with a locking nut at the back of the horn for tone adjustment. Do not meddle with it unless it requires adjustment. If the horn gives only a choking sound, or does not vibrate, it does not mean that the horn has broken down. The trouble may be due to a discharged battery, a loose connection, or short-circuit in the wiring of the horn. It is also possible that the performance of the horn may deteriorate due to its mounting becoming loose.



However a setting screw is provided which is covered by a protective rubber cap. If the horn sound is feeble then minor corrections are possible by means of this setting screw.

To carry out adjustments please proceed as follows:

Remove protective rubber cap

Turn in the small screw very carefully at the same time check for functioning of the horn

Stop adjusting when the desired sound level is obtained.

Refit the protective rubber cap over screw when adjustment is complete.

NOTE: IF the adjusting screw is turned in too much the horn would only give a choking sound or if it is turned out too much the sound would be very feeble.

WORKSHOP MANUAL BULLET

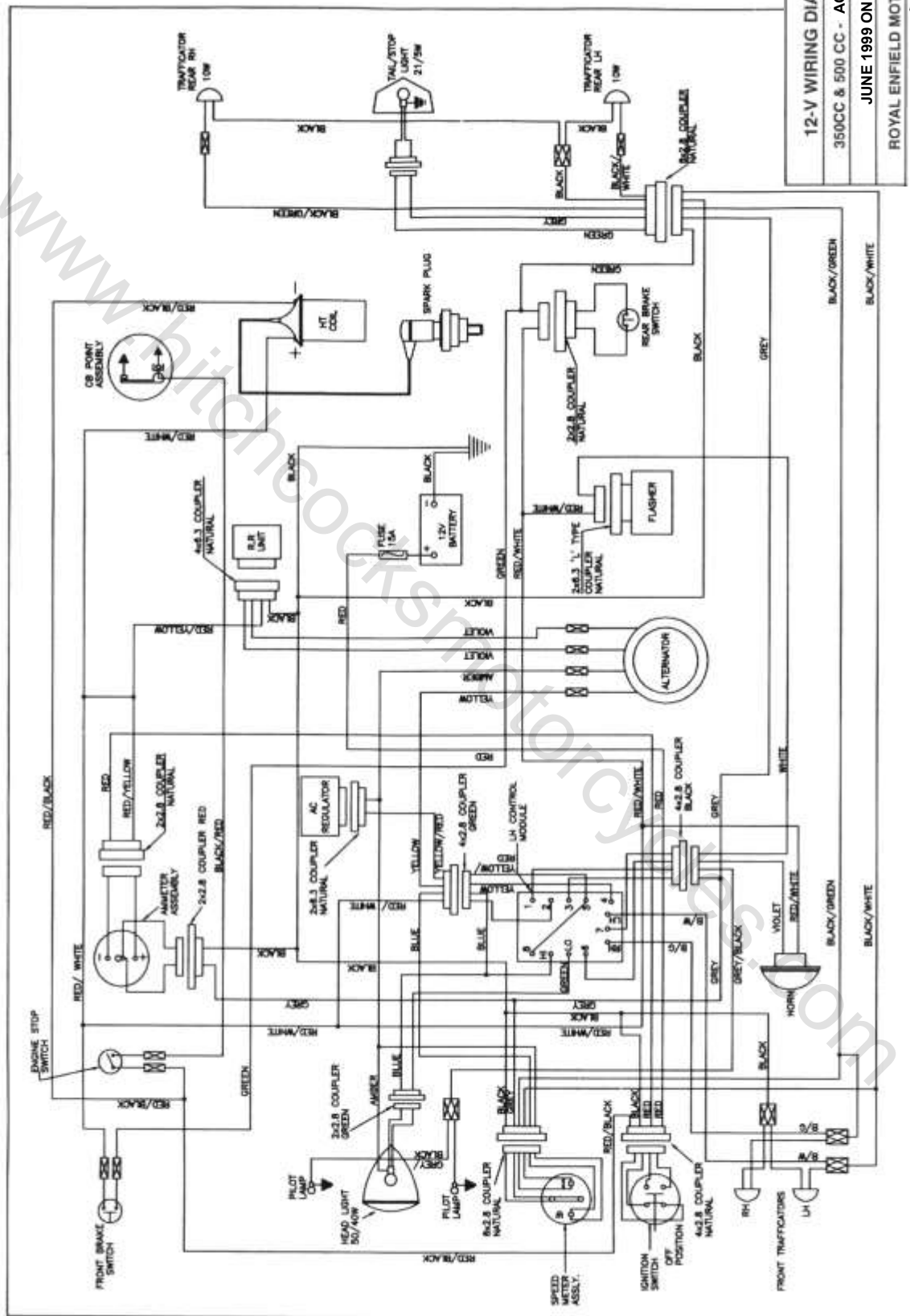

12-V WIRING DIAGRAM
 350CC & 500 CC - AC/DC
 JUNE 1999 ON
 ROYAL ENFIELD MOTORS LTD.

WORKSHOP MANUAL BULLET

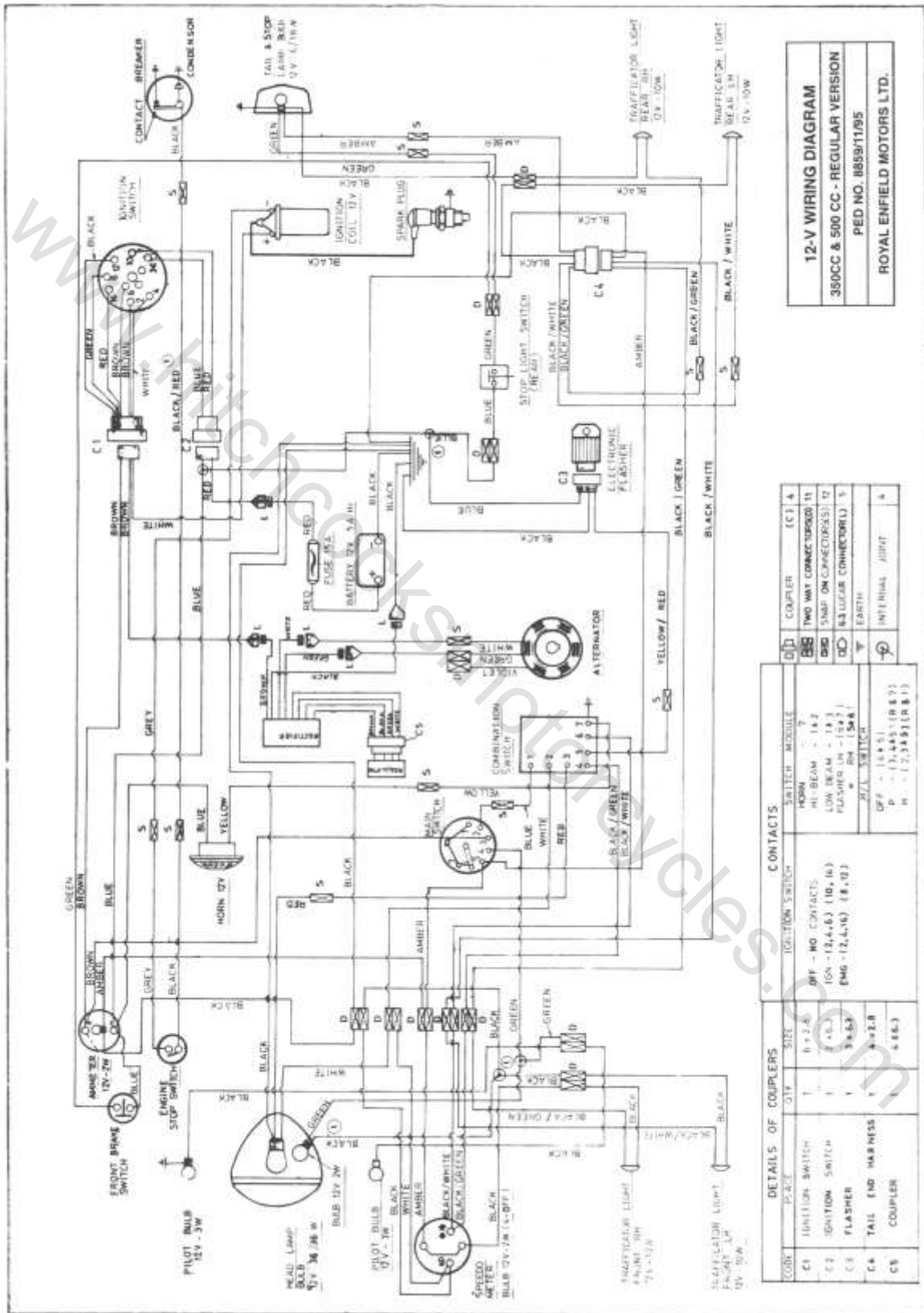

DETAILS OF COUPLERS		CONTACTS	
CODE	PLACE	SIZE	TOUCH-ON SWITCH
C1	IGNITION SWITCH	11 x 2.8	HORN
C2	IGNITION SWITCH	4 x 6	HI-BEAM
C3	FLASHER	3 x 8.5	LOW-BEAM
C4	TAIL END HARNESS	11 x 2.8	FLASHER LH - (1, 2)
C5	COUPLER	4 x 6	FLASHER RH - (1, 2)

CONTACTS	
OFF	ON
OFF - (1, 4, 5)	ON - (1, 4, 5) (R & Y)
OFF - (2, 3, 4, 5) (R & Y)	ON - (2, 3, 4, 5) (R & Y)

CODE	COUPLER	CONTACTS
C1	TWO WAY CONTACT	11
C2	SWITCH ON CONTACTS	12
C3	83 LOGIC CONNECTOR	5
C4	FLASHER	5
C5	INTERNAL JUNCTION	4

WORKSHOP MANUAL BULLET

ELECTRICAL CONNECTION DETAILS

1. Alternator assembly

The three output wires from the alternator should be connected to the main cable harness through snap on connectors.

Connect the wires as follows:

<i>Alternator</i>		<i>Wiring Harness</i>		
		UK	US/Canada	Regular
White	to	white	white *	white
Violet & green	to	green	green	green

** In certain Vehicles the wire colour Is violet*

CAUTION: Do not interchange the above connections to prevent overcharging of the battery.

2. Regulator cum Rectifier

The connections are as follows:

<i>Regulator</i>	<i>Wiring Harness</i>		
	UK	US/Canada	Regular
Brown	Brown(+ve)	Brown (+ve)	Brown(+ve)
Black	Black(-ve)	Black(-ve)	Black(-ve)
Green	Green(AC)	Green(AC)	Green(AC)
White	White(AC)	White(AC)	White(AC)

3. Ignition Coil

(LT connections) UK Version: connect white wire from terminal no.6 of ignition switch to +ve terminal of coil and black/white wire from CB point assembly to -ve terminal of coil.

US/Canada: Connect white wire from engine stop switch at the handle bar to +ve terminal of the coil and black wire from CB point assembly to -ve terminal of the coil.

Regular version: Connect white wire from terminal no.4 of ignition switch +ve terminal of coil and grey wire from engine stop switch to -ve of the coil

HT connections: Connect HT lead to the centre of the coil and the spark plug cap.

4. Stop - Run switch on handle bar

Only for US/Canada and Regular versions

US/Canada: Connect brown/white wire from switch to -ve terminal of ammeter

Regular: Connect black wire from switch to CB Point.

5. Battery

Connect the earth wire (black) from harness to -ve terminal of the battery and the main wire (red) from the fuse carrier to the +ve terminal of the battery.

Caution: Do not connect the battery to the main cable harness without the fuse carrier and never interchange the battery terminal connections.

WORKSHOP MANUAL BULLET

6. Ignition Switch

The ignition switch has basically 3 positions. The functions and connections are given below. The wire connections are through non interchangeable couplers.

UK Version

Key position (rider seated)	Control Contacts
Centre	Ignition off, battery circuit off, key can be removed
Clockwise	Ignition and battery Circuits ON Terminals(2,4,6) (11 & 13) are connected. Key cannot be removed
Anticlockwise	Ignition off, battery circuit ON. Pilot and tail lamp glows. Key can be removed to facilitate night time parking with pilot lights ON

Terminal Connections	
Terminal Number	Wire Colour
11 (+ve from battery)	Red
13	Blue
2 (+ve from RR unit)	Brown
4	Brown
6	White

Regular version:

The ignition switch is the same as UK version switch except that the switch has no function in the anticlockwise position and the terminal connections are different as follows:

Terminal Connections	
Number	Wire colour
2 (+ve from RR unit)	Brown
4	White
6	Brown
10 (+ve from battery)	Red
14	Blue

US/Canada Version

The ignition switch is located on the head lamp casing in place of the head light switch.

Position 1 Ignition and battery circuits off.

Position 2 & 3: All circuits ON and headlight illuminates moment switch is ON.

WORKSHOP MANUAL BULLET

7. Main Light Switch

This switch is applicable only to UK and regular versions. The main light switch is located on the head lamp casing and has 3 positions.

In the UK version the centre position is off and in the Regular version the extreme left is off position.

The wiring connections are as follows:

P	Pilot lamps on
Off	All lights off
H	Pilot and head light on.

UK Version		Regular Version	
Wire Colour	Terminal No.	Wire Colour	Terminal No.
Brown	2	Blue	2
Blue	3	Brown	3
Red	5	Green	4
Green & Amber	6	Amber	5

8. Handle Bar Switch

The handle bar switch provided on the left side of the handle bar consists of head lamp high & low switch (head lamp day flash only in UK & US/Canada versions) trafficator switch and horn push button. The wires are pre-soldered to the terminals and connections are through couplers and snap on connectors. The colour of the wiring connections are given for reference purposes.

Terminal No	Wires colour			Connections for
	UK	US/Canada	Regular	
1	Blue	green	Blue	H-lamp supply
2	Red	Red	White	H-lamp Hi beam
3	White	White	Red	H-lamp Lo beam
4	Brown	Brown	-	H-lamp day flash
4	-	-	Black/green	Trafficator Lamps
5	-	-	Yellow/red	Trafficator supply
6	-	-	Black/white	Trafficator lamps
7	-	-	Yellow	Horn
8	Yellow/red	Yellow/red	-	Trafficator supply
9	Black/white	Black/white	-	Trafficator lamps
10	Black/green	Black/green	-	Trafficator lamps
13	Yellow	Yellow	-	Horn

9. Horn

Connect the lucar terminals blue and yellow to the horn and ensure the protective sleeve is in position over the connections.

10 Brake light switches

There are 2 switches provided, one near the front brake lever and the other inside the LH tool box.

The connections are blue and green wires

The front brake light switch connects inside the head lamp casing, using lucar connectors, and the rear brake wire connections are through snap on connectors

NOTE: Ensure all earth connections are clean and firm and the wires are fully inserted into the snap on connectors lucar terminals and couplers.

Check and correct any electrical faults before replacing blown fuse links.

Do not interchange battery terminal connections and regulator cum rectifier connections.

WORKSHOP MANUAL BULLET

CARBURETTOR

Bullet Motorcycles are fitted with MIKCARB Carburettors

350cc	-	VM-24 Type
500cc	-	VM-28 Type

Function

The function of the carburettor is to provide combustible Air-fuel mixture by breaking the fuel into tiny particles - in the form of vapour and mixing the fuel vapour with air in a proper ratio and deliver it into the engine combustion chamber.

In general, all carburettors are designed to provide the engine with the designed ratio of atomised fuel-air mixture at the required quantity levels to cater to both load and road speed of engines.

In the Mikcarb carburettors fitted to 350cc and 500cc Bullet Motorcycles, the atomisation and mixing of fuel and air is carried out by three systems, viz.:

STARTING JET SYSTEM or CHOKE SYSTEM

PILOT JET SYSTEM

MAIN JET SYSTEM

1. Starting Jet System

The starting jet system provided in this carburettor is to aid starting, under adverse condition such as that experienced during cold winter mornings.

The starting jet system comes into operation, when the choke lever is pushed down and thereby lifting the choke plunger from its seat. This enables an additional quantity of fuel to be supplied to the engine in addition to that of pilot jet system.

This action makes the fuel air mixture to become richer for easier starting.

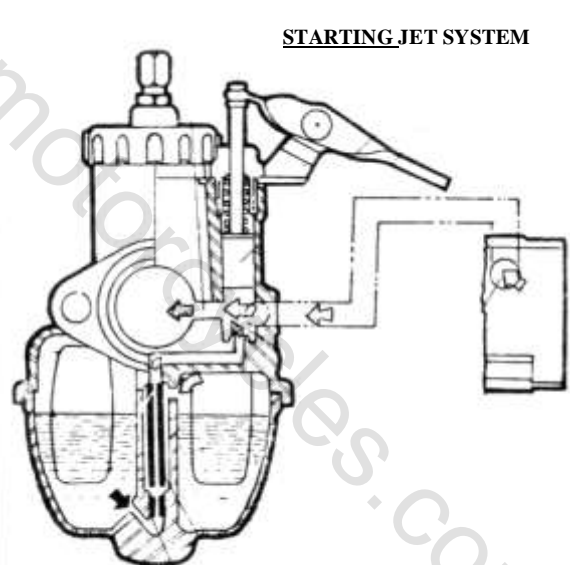

WORKSHOP MANUAL BULLET

2. Pilot Jet System

The pilot jet system supplies the engine requirements at lower engine speeds only, i.e. during idling rpm. This function is carried out by the pilot jet and pilot air screw. The pilot air screw governs the air fuel mixture ratio. Adjusting the screw by screwing in beyond the specified limits would make the mixture rich and vice versa.

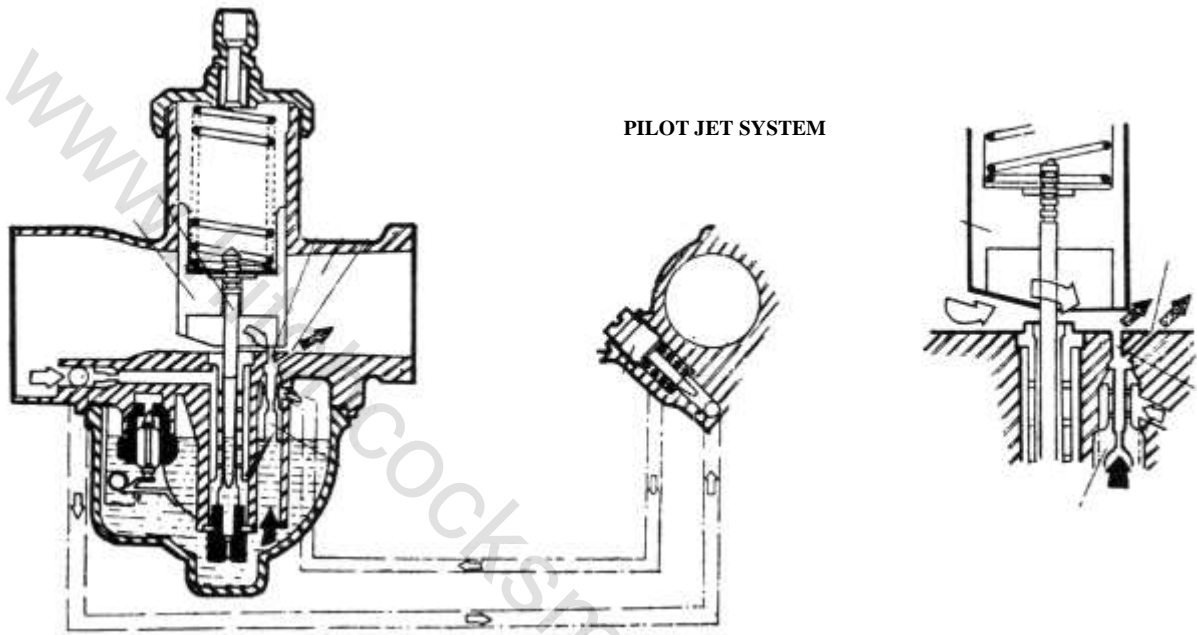

3. Main Jet System

The main jet system comes into operation at speeds above idling, i.e. the moment throttle slide is lifted. When, once the main jet system becomes functional, it provides to the by-pas circuit for the pilot jet system. As such, the pilot jet system becomes totally inoperative during main jet system operation.

This main jet system comprises of the main jet, the needle jet and the taper needle. The fuel flows through the main jet (also known as metering jet) during the main jet operation.

The taper needle, which is mounted on the throttle slide, while operated up and down increases or reduces the cross sectional area between the needle jet bore and the needle. This in turn monitors the quantity of atomised fuel supplied with respect to engine speed & load.

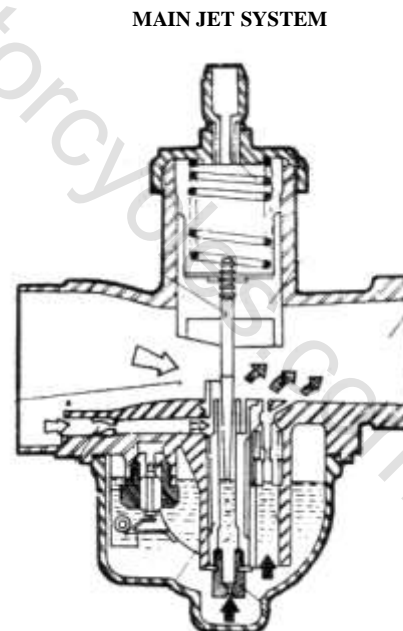

WORKSHOP MANUAL BULLET

MIKCARB CARBURETTOR VM28 (500 C.C.)

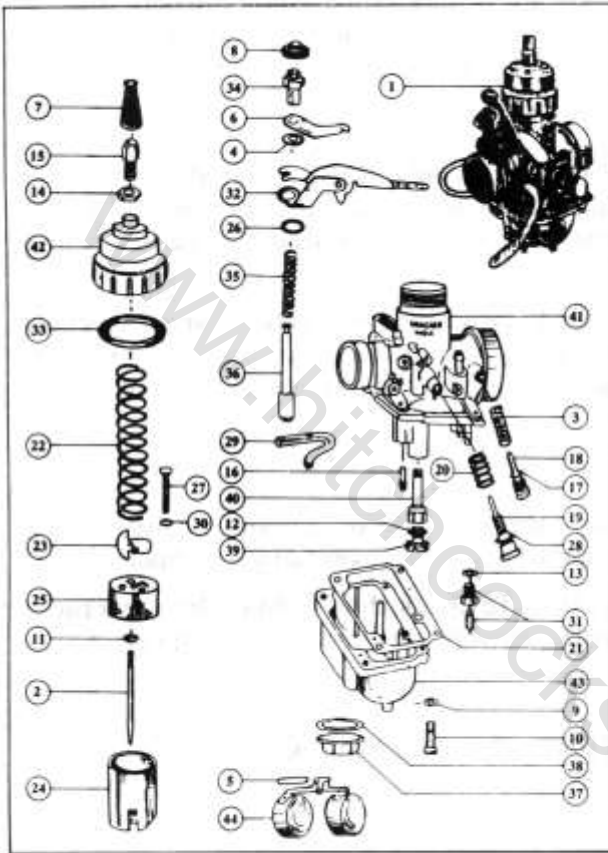

MIKCARB CARBURETTOR (VM 24 - 350 CC)

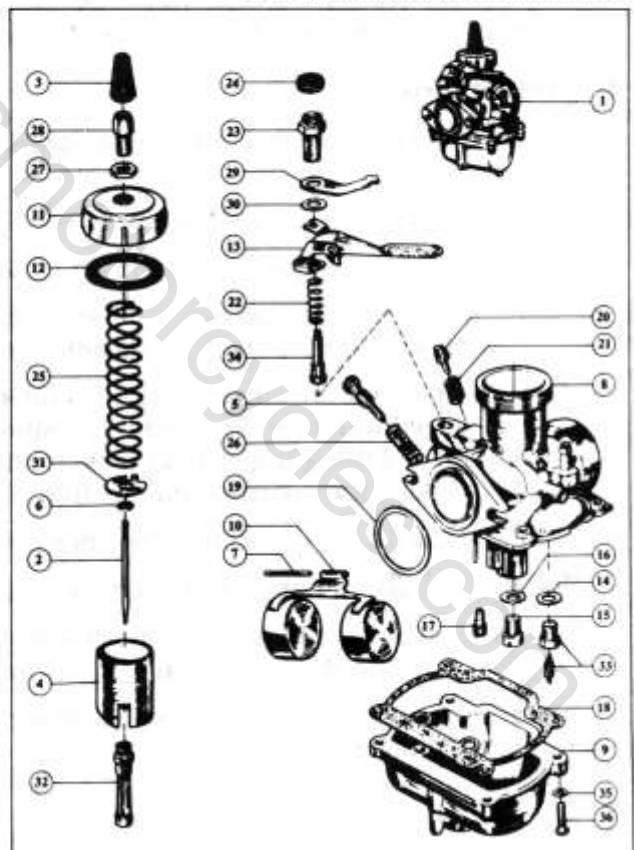

WORKSHOP MANUAL BULLET

The taper needle shank has five grooves in it, so that it can be set in relation to the throttle slide. If the needle is set higher on the throttle slide, the quantity of fuel that is being supplied would become much more, than if it would have been set at a lower position. However, it is to be noted that the fuel supplied is governed by the above mechanism only on part throttle condition. With the throttle fully opened, the fuel supplied is monitored by the main jet only. The recommended position for the Needle Lock is the 2nd or 3rd groove from bottom.

4. Servicing

The carburetter should be cleaned thoroughly with petrol only. Ensure that all parts are in serviceable condition. Before mounting the carburetter, always ensure that the slide is free to move up and down by operating the throttle twist grip. Also ensure that the starter piston (choke plunger) is properly set in position.

CAUTION: Never use a sharp instrument or wire to clean the carburetter parts especially jets and passages. If the passages are blocked, use only pressurised air to clear the passages. Handle all parts gently and with great care. Run down all threaded attachments gently. Never use force.

5. Mounting

Special care must be exercised while mounting the carburetter. Ensure positioning of carburetter is vertical and the gasket, 'O' Ring is serviceable, to prevent any air/gas leak.

In 500cc models, Rubberised Inlet Manifold is fitted. To check the condition for any crack, or otherwise a cracked manifold will result in starting trouble and erratic idling speed.

6. Setting Idling

It is always recommended to set idling speed of the engine while the engine is still warm, i.e. after a short run.

The procedure for setting idling speed is:

- a) Start the engine and warm up for 2 to 3 minutes.
- b) Turn the pilot air screw down to the bottom and reduce the engine RPM to the slowest rate, using the idle adjusting screw.
- c) Open out the air screw slowly and keep watch on engine speed. At a point, engine speed will increase. Find the position where the engine RPM is maximum and the engine firing uniform. This is normally between 2 to 3 half turns of the air screw ($360^\circ + 180^\circ$ Turns) from its fully closed position.
- d) Now adjust the idling RPM once more with the idling screw.

NOTE: 1. Take out any excessive play in the throttle cable.

2. Turn the handle bar to left side & right side to ensure that the throttle cable is free and does not foul with any other part in the routing of the cable.

Besides the above two settings, no other settings to the carburetter is required for normal operating conditions.

WORKSHOP MANUAL BULLET

TROUBLE SHOOTING : BULLET MOTOR CYCLES

COMPLAINT: ENGINE DIFFICULT/DOES NOT START

CHECK	OBSERVATION	CAUSES	REMEDIES
1. Crank the engine several times. How is the cranking pressure?	Kick starter pedal moves freely.	1) Clutch slippage: No clutch cable free play	Adjust clutch cable play
		Stuck clutch cable Weak clutch springs	Clean and free the cable Change the clutch springs
		Worn out clutch plates	Replace the clutch plates
	2) Compression weak: Loose spark plug Tight tappet adjustment	Tighten the spark plug Adjust the tappets correctly Change the gasket	
	Blown cylinder head gasket Leaky valves Worn out/scored cylinder Worn out piston rings Jammed piston rings Glazed cylinder	Lap the valves Rebore to next over size	
	Leaky decompressor	Replace piston rings Clean and fit Rebore the cylinder to next o.s. Check and change the gaskets Lap the decompressor valve	
	Loose cylinder head nuts	Tighten the nuts	
	Cranking pressure OK	3) Kick starter pawl slipping	Change the pawl/spring
2. Remove the fuel hose from the carburettor. Turn the fuel tap to On/Reserve. Does fuel flow to carburettor?	No, it doesn't	No fuel in the tank	Fill up the tank
		Blocked fuel tank cap vent	Clear the vent
		Chocked fuel tap	Clean fuel tap
	Yes, it flows		
3. Check fuel. How is it?	It is stale, gives an offensive odour	Vehicle not used for long periods	Clean petrol tank and carburettor and fill the tank with fresh petrol
	It is adulterated	Kerosene/Diesel in Petrol	Select a reliable pump
	Petrol is OK		

WORKSHOP MANUAL BULLET

TROUBLE SHOOTING : BULLET MOTOR CYCLES

COMPLAINT: ENGINE DIFFICULT/DOES NOT START

CHECK	OBSERVATION	CAUSES	REMEDIES
1. Crank the engine several times. How is the cranking pressure?	Kick starter pedal moves freely.	1) Clutch slippage: No clutch cable free play	Adjust clutch cable play
		Stuck clutch cable Weak clutch springs	Clean and free the cable Change the clutch springs
		Worn out clutch plates	Replace the clutch plates
	2) Compression weak: Loose spark plug Tight tappet adjustment	Tighten the spark plug Adjust the tappets correctly Change the gasket	
	Blown cylinder head gasket Leaky valves Worn out/scored cylinder Worn out piston rings Jammed piston rings Glazed cylinder	Lap the valves Rebore to next over size	
	Leaky decompressor	Replace piston rings Clean and fit Rebore the cylinder to next o.s. Check and change the gaskets Lap the decompressor valve	
	Loose cylinder head nuts	Tighten the nuts	
	Cranking pressure OK	3) Kick starter pawl slipping	Change the pawl/spring
2. Remove the fuel hose from the carburettor. Turn the fuel tap to On/Reserve. Does fuel flow to carburettor?	No, it doesn't	No fuel in the tank	Fill up the tank
		Blocked fuel tank cap vent	Clear the vent
		Chocked fuel tap	Clean fuel tap
	Yes, it flows		
3. Check fuel. How is it?	It is stale, gives an offensive odour	Vehicle not used for long periods	Clean petrol tank and carburettor and fill the tank with fresh petrol
	It is adulterated	Kerosene/Diesel in Petrol	Select a reliable pump
	Petrol is OK		

WORKSHOP MANUAL BULLET

TROUBLE SHOOTING: ENGINE DIFFICULT/DOES NOT START

CHECK	OBSERVATION	CAUSES	REMEDIES
4. Switch 'on' ignition and crank engine. Does the amp. meter needle deflect?	a) No, it doesn't	Kill switch circuit open Defective ignition switch Snapped battery connection Snapped LT lead CB points not closing Open primary circuit Fully discharged battery	Check and correct Replace ignition switch Check and correct Check and correct Adjust the points Check and correct Charge the battery
	b) Yes, it always remains in discharged position	Shorted kill switch Shorted ignition switch C.B. points not opening Shorting at CB points	Replace the kill switch Replace ignition switch Adjust CB points Check and correct
	c) It is OK		
5. Remove spark plug. Cover the spark plug hole with thumb. Crank engine several times. How is the petrol smell? Is there petrol stain on thumb?	a) No petrol smell. No fresh petrol stain on thumb.	Stuck open slide valve Less petrol flow to the bowl Blocked carburettor fuel inlet Stuck closed float needle Float height too high Blocked pilot jet/pilot discharge orifice Warped inlet flange Loose inlet fasteners	Free the slide valve Clean the passage Clean and free float needle Adjust float height Clear the jet/discharge orifice Face the flange Tighten fasteners
	b) Heavy petrol smell. Petrol wets thumb.	Too rich air petrol mixture from carburettor: Dirt on float needle seat Damaged float needle valve Punctured float assembly Float height adjusted too low Loose/Worn out pilot jet Blocked pilot jet bleed holes Stuck open choke Choke on hot engine Air screw too far in	 Clean the needle seat Replace the needle valve Repair/Replace the float Adjust float to right height Tighten/Replace pilot jet Clean the jet bleed holes Check, clean and fit the choke Pull choke to 'off' position Adjust the air screw
	c) Too much oil on thumb	For causes and remedies refer to high lube oil consumption	
	d) It is normal		

WORKSHOP MANUAL BULLET

6. Clean spark plug electrode tips. Set gap. Connect it to HT lead. Earth its body. Turn ignition switch "on". Ensure "kill switch" is in Run position. Crank the engine. How is the spark?	a) No spark	Defective spark plug Defective plug cap Open primary circuit Defective HT coil	Change the plug Change the cap Check and correct Change the HT coil
	b) Red/Yellow spark	Defective HT lead Excessive electrode gap Loose connections Dirty, pitted CB points Discharged battery Defective HT coil	Replace HT lead Adjust the gap Tighten all connections Clean and adjust CB points Re-charge the battery Change HT coil
	c) Side spark or intermittent spark	Cracked spark plug insulator Loose connections Fouled spark plug Cracked HT lead	Change the spark plug Tighten connections Clean and adjust the gap Change the HT lead
	d) Light blue solid spark.		
7. Is the spark plug of right specification	No	Shorter reach spark plug	Replace with right plug
	Yes		
8. Is the ignition timing correct?	No	Too far advanced / retarded Ignition timing	Adjust ignition timing
Yes, it is correct			
Then, now, engine should start easily			

NOTE: 1. Combustion elements: Fuel, Air and Heat.

2. Right compression heats up the air petrol mixture. Light blue spark at the right time ignites it and engine starts.

3. Right compression pressure for bullet - 6.5 kg/cm^2 to 8.5 kg/cm^2 .

4. Check ignition coil as follows: Remove spark plug cap from HT lead. Turn ignition switch 'on'. Hold the HT lead end about 8 m.m. away from cylinder head. Crank the engine. Continuous light blue spark jumping from the lead indicates the primary circuit and the HT coil are ok.

WORKSHOP MANUAL BULLET

COMPLAINT: LOW IDLING PROBLEM

CHECK	OBSERVATION	CAUSES	REMEDIES
1. Does the engine cut off suddenly when the throttle is closed but remain running as long as throttle remains partly open?	a) Yes, it cuts off.	Throttle stop screw too far out Air screw too far in Pilot jet blocked Pilot discharge orifice blocked Weak compression Too far advanced ignition Too far open CB points Stuck open auto adv. ign. unit	Adjust throttle stop screw Adjust air screw Clean pilot jet Clean the pilot orifice Check and correct Check and adjust Check and adjust Check and correct
	b) No, it does not cut off		
2. How is the engine running in throttle fully closed position?	a) It gradually cuts off without excessive smoke	Loose carburettor mounting Warped carburettor flange Air screw too far out Loose LT connection	Tighten the mounting Check and correct Adjust the air screw Tighten the connections
	b) It cuts off gradually with smoke and heavier exhaust sound	Excessive fuel flow to the engine: Air screw too far in Dirt between float needle valve and seat Damaged float needle valve Punctured float Faulty float height adjustment	Adjust air screw Clean needle valve and seat Replace float needle valve Replace float Correct float height
	c) OK		
3. Is the engine low idle rpm higher?	a) Yes, it is higher	No throttle cable free play Throttle stop screw fully in Stuck throttle inner cable Partly stuck open slide valve Restricted fuel flow to float chamber Aux air screw move out Air screw too far out	Adjust throttle cable play Adjust as required Clean/Replace cable Clean and free the slide valve Check and correct Check and adjust Adjust the air screw
	b) No, it is not		
4. Does the engine low idle erratically?	a) Yes, it does	Air screw too far out Auxiliary air screw too far out Suction leakage Worn out slide valve	Adjust the air screw Adjust auxiliary air screw Check and correct Replace slide valve
	b) No, it doesn't		
5. Does the engine misfire and cut off?	a) Yes, it does	Excessive spark plug gap Fouled spark plug Faulty HT coil/cord Dirty CB points Water in petrol Low level of petrol in float chamber	Adjust gap to 0.5 mm Clean and adjust spark plug Replace the HT coil/cord Clean and readjust Replace petrol Adjust the float height to 29 ±1mm
	b) No, it doesn't		

WORKSHOP MANUAL BULLET

CHECK	OBSERVATION	CAUSES	REMEDIES
COMPLAINT : LOW IDLING PROBLEM			
6. With Ignition on, kick the engine. Is there a severe kick back?	Yes	Too far advanced ignition timing	Adjust ignition timing
		High compression pressure	Check and correct
	No		
Engine would now low idle smoothly			

NOTE	:	Find out induction leakage by:
METHOD 1	:	Pour some petrol at the suspected joint. If engine cuts off, there is suction leakage at that joint.
METHOD 2	:	Pour some lube oil or apply grease at the suspected joint. If the slow running improves, there is leakage at that joint.

www.hitchcocksmotorcycles.com

WORKSHOP MANUAL BULLET

COMPLAINT: LOSS OF POWER

CHECK	OBSERVATION	CAUSES	REMEDIES
1. Is the load on engine O.K?	a) No, it is over loaded.	Excessive pay load Low tyre pressure Tight chain - Primary and Rear Brake binding Too much oil in gear box or primary chain case. Sticky wheel bearing	Reduce pay load Inflate the tyre to right pressure Adjust chain tension Adjust brake Drain and correct Clean and lubricate the bearings
	b) Yes		
2. Does the road speed increase in proportion with engine rpm?	a) No	Clutch slippage: Causes & remedies as given for clutch slippage complaint (Page 14).	
	b) Yes		
3. How is the smoke?	a) Excessive smoke	Adulterated petrol	Replace Petrol
		Carburettor flooding	Check and correct
	Blocked air bleed holes	Clean the bleed holes	
		Blocked air jet	Clean the air jet
		Stuck open choke plunger	Check and correct
		Chocked air filter	Clean air filter
		Weak spark	Check and correct
		Too far retarded ignition timing	Adjust ignition timing
		Poor compression: Causes & remedies as given for weak compression in check 1 in 'engine difficult to start'.	
	b) No smoke	Blocked petrol jets	Clean them
		Too less petrol in float chamber	Check and correct
	c) Normal		
4. Does the engine over heat?	a) Yes	Causes and remedies as given for the complaint 'engine over heating' (Page 14	
	b) No		
Then, the engine will have full power.			

WORKSHOP MANUAL BULLET

COMPLAINT: HIGH LUBE OIL CONSUMPTION

CHECK	OBSERVATION	CAUSES	REMEDIES
1. Check the parked place any oil spot on the ground?	Yes, External oil leaks	Loose drain plugs Loose joints Damaged gaskets Damaged sealing surface	Tighten the plugs Tighten fasteners Replace the gaskets Face / Replace the parts
	No		
2. Start the engine. How is the oil throw from the breather pipe?	Excessive oil throw from breather for few minutes when the engine is started first time in the day	Excessive oil in oil tank Timing shaft hole in crankcase worn out Excessive run out of timing shaft Crankcase mounting nuts loose Gasket between oil tank and crankcase housing damaged Porosity / Blow hole in crankcase	Drain and correct the level Turn it and fit a bush Replace the crank shaft Tighten them in sequence after loosening them by 1/4 turn Replace the gasket Change the crankcase
	Excessive oil throw from breather through out the engine operation	Air vent in lube oil dip stick cover blocked Return pump not operating Blocked return pump passages Excessive blow by	Clean the vent hole Check and correct it Clean the blockages Check and correct
	No oil throw from breather		
3. Start the engine and accelerate. How is the smoke?	Excessive white smoke	Wrong grade or recycled lube oil Worn out valve guide or valve stem Piston, piston rings or cylinder wall worn out Connecting rod bent Wrong piston ring fitment	Use SAE 20w - 50 oil Replace valve guide and valve Replace the worn out parts Replace the connecting rod Fit the ring correctly
	No white smoke		
The oil consumption will then be OK.			

WORKSHOP MANUAL BULLET

COMPLAINT: HIGH LUBE OIL CONSUMPTION

d)	Method of checking oil circulation:
1	: Remove the tappet inspection door. Continuous oil flow through the push rod while the engine is in operation indicates proper oil circulation.
2	: Loosen the banjo union at the cylinder head. Engine in idling, oil flow from this joint indicates proper oil circulation up to this point.
3	: While engine is idling, loosen the feed plug. Solid oil flow from here indicates proper functioning of feed pump.
e)	Method of finding oil leaks to crankcase from cork seal, crank shaft timing end bush & joint between crank case and oil tank:
1	: Keep the motor cycle on a level ground.
2	: Remove the return pump filter plug and drain the oil completely from crank case chamber / flywheel chamber.
3	: Check and top up oil in tank to 'H' mark on dip stick.
4	: Refit the return pump filter plug.
5	: Keep the motor cycle in this way for 24 Hrs. During this period do not crank or start
6	: Now, remove the return pump filter plug and collect the oil that may drain from the crank case in a bowl. If no oil is draining, there is no leakage from oil tank and timing chest to crank case.
7	: If oil get collected and oil level in sump is unchanged then leakage is from T chest.
f)	Method of checking return pump operation:
1	: Ride the vehicle for one or two kms or start and run the engine for 10 mts.
2	: Keep the motor cycle on stand and switch off the engine.
3	: Remove the return pump filter plug and collect the draining oil in a bowl.
4	: About 50 to 75 ml oil will normally be there to drain. If oil drained measure more than 100 ml, operation of return pump can be suspected.

NOTES:	a)	Oil seepage into crank case when engine is at rest, results in the flywheel dipping through the accumulated oil. When engine is started the resultant excessive oil splash causes oil escape through breather during the first few minutes of engine operation.
	b)	Failure of return pump causes excessive oil accumulation in crank case throughout engine operation. The fly wheels dip through it. Excessive splash thus caused ends up with continuous oil through from the breather.
	c)	Excessive blow-by results in excessive gas flow through the crank case to the breather. The flowing gas picks up the splashed oil at the crank case. This ends up with continuous oil throw from the breather.

WORKSHOP MANUAL BULLET

COMPLAINT: LOW MILEAGE

CHECK	OBSERVATION	CAUSES	REMEDIES
4. Does the road speed increase with engine rpm?	No, it doesn't	Clutch slippage: Causes and remedies as given for clutch slippage problem (Page 15)	
	Yes, it does		
5. Is there excessive white smoke?	Yes	Causes and remedies as given against white smoke in high oil consumption (Page 7)	
	No		
6. Does the engine misfire?	Yes, it does	Fouled spark plug Too much spark plug electrode gap Cracked spark plug insulator Defective condenser Dirty/pitted C.B. points Defective HT coil Too rich air petrol mixture	Clean the spark plug Adjust the gap Change the spark plug Replace the condenser Clean and adjust the points Replace them Check and correct
	No, it doesn't		
7. Is there starting problem, poor pickup and more smoke?	Yes	Weak spark Too far retarded ignition timing Low compression Too much oil entry into combustion chamber	Check and correct Check and adjust ignition timing Check and correct Check and correct
	No		
8. Does the engine over heat?	Yes, it overheats	For causes and remedies refer to engine over heating complaint (Page 11)	
	No, it doesn't		
Now the vehicle mileage will be good.			

WORKSHOP MANUAL BULLET

ENGINE OVER HEATING

CAUSES	REMEDIES
Too lean air petrol mixture (characterised by loss of power)	Check and correct
Too far advance ignition timing (characterised by kick back while starting and combustion knocks)	Adjust the timing
Excessive carbon deposit in cylinder (Characterised by post ignition)	Decarbonise the engine
Dirty/ Blocked cooling fins	Clear and clean the fins
Oil starvation	Check and correct
Wrong grade oil	Change the oil
Engine over loaded	Reduce the load
Wrong spark plug	Replace it with correct plug
Less working clearances between moving parts	Check and correct

WORKSHOP MANUAL BULLET

COMPLAINT: ENGINE NOISY IN OPERATION

CHECK	OBSERVATION	CAUSES	REMEDIES
1. Start and accelerate the engine. Any high intensity continual, gas leakage sound?	Yes	External compression leakage Exhaust gas leakage	Check and correct Check and correct
	No		
2. Start and run the engine. Any continuous air flow sound?	Yes	Cracked / damaged air below Torn / damaged air filter	Change it Change it
	No		
3. Is there humming / howling noise	Yes	Tight gears	Check and correct the back lash
	No		
4. Is there a continuous metallic tapping noise?	Yes	Excessive tappet clearance Excessive small end clearance Dry auto adv. ign. unit Loose valve stem cap Damaged cams Loose rocker in bush	Adjust the tappets Check and change the worn part Check and lubricate Change the cap Change the cam wheels Change the bush
	No		
5. Is there a continuous grinding like noise	Yes	Worn out ball bearing	Replace them
	No		
6. Does the knock reduce with increasing engine temperature?	Yes	Too much clearance between piston and cylinder	Change the worn out part
	No		
7. Does the noise increase with temperature	Yes	Engine over heating Excessive compression ratio Too far advanced, ignition	Check and correct Check and correct Check and adjust
	No		
8. Does the knock increase with the load?	Yes	Worn out floating bush Loose chain adjuster Loose engine sprocket	Change the floating bush Check and correct Replace the sprocket
	No		
Then, the engine would run smoothly.			

WORKSHOP MANUAL BULLET

COMPLAINT: PREMATURE WEAR OF ENGINE COMPONENTS

CHECK	OBSERVATION	CAUSES	REMEDIES
1. Is there any suction leakage or air filter damage?	Yes	Cracked or improperly fitted air filter Induction system joint leakages	Replace the air filter or properly fit it Check and correct
	No		
2. Is the petrol dirty adulterated?	Yes	Rusted tank Water contaminants in petrol Torn fuel tap filter Adulterated petrol	Clean the tank Replace the petrol Replace the filter Change the petrol
	No		
3. Is engine oil dirty	Yes	Neglected maintenance Use of recycled oil	Replace oil at regular intervals Use specified oil
	No		
4. Does the engine over heat?	Yes	For causes and remedies refer to engine over heating complaint.	
	No		
5. Does the engine produce unusual sounds or knocks?	Yes	Excessive clearance loose adjustments Worn out bearings / component surfaces	Check and correct Check and correct
	No		
Keep the causes of premature wear away to ensure long life for engine components.			

Note: Use of non-genuine parts causes premature wear.

COMPLAINT: FLAME AT THE CARBURETTOR (BACK FIRE)

CAUSES	REMEDIES
Too lean air petrol mixture	Check carburettor setting and adjust
Use of smaller size Jets	Change the jets
Over heated engine	Check and correct
Leaky in take valve	Check and adjust tappet lap the valve on its seat

WORKSHOP MANUAL BULLET

COMPLAINT: FLAME AT THE SILENCER (AFTER FIRE)

CAUSES	REMEDIES
Defective spark plug Too rich air fuel mixture Retarded ignition timing Leaky exhaust valve	Clean & adjust or replace Adjust carburettor Check and adjust ignition timing Adjust tappet Lap the valve

COMPLAINT: CLUTCH SLIPPAGE

CHECK	OBSERVATION	CAUSES	REMEDIES
1. Does the road speed increase with engine rpm?	No	Clutch slippage: No clutch lever free play Worn out clutch plates Weak pressure springs Glazed steel plate / clutch plates Distorted pressure plates	Adjust clutch cable free play Replace clutch plates Replace springs Replace the glazed plates Replace the distorted plates
	Yes		
Then there is no clutch slippage			

WORKSHOP MANUAL BULLET

COMPLAINT: CLUTCH DRAGGING

CHECK	OBSERVATION	CAUSES	REMEDIES
1. Does the vehicle tend to move on engaging gear though clutch lever is fully depressed?	Yes	Excessive clutch lever free play Distorted steel plates Dirty/high viscous oil Broken friction plates Damaged clutch rod and ball adjuster	Check and adjust Replace steel plates Replace with SAE 10w-30 oil Replace the broken plates Replace the damaged part
	No		
Then there is no clutch dragging			

COMPLAINT: GEARS DIFFICULT TO ENGAGE

CAUSES	REMEDIES
Clutch drag	Check and correct
Tight gears	Check and correct
Faulty selector adjustment mechanism adjuster plate adjustment	Check and adjust
Too tight gear operator selector assy. adjustment	Check and adjust

WORKSHOP MANUAL BULLET

COMPLAINT: PREMATURE WEAR OF DRIVE CHAIN AND SPROCKET

CAUSES	REMEDIES
Too tight chain adjustment	Adjust the chain to its normal slackness
Too loose chain adjustment	Adjust the chain to its normal slackness
Over loading of motorcycle	Reduce the load
Misalignment of F.D sprocket with rear wheel sprocket due to faulty chain adjustment	Adjust the chain tension properly
Too much dirt on chain	Clean and lubricate
Chains roller and pin runs dry	Clean and lubricate
Faulty cush drive	Replace cush drive

COMPLAINT: TYRE / TUBE DAMAGES PREMATURELY

INDICATIONS	CAUSES	REMEDIES
Excessive wear at the tread edges	Low tyre inflation pressure	Inflate the tyres to the right pressure
Tyre side wall cracks	Low tyre inflation pressure	Inflate the tyres to the right pressure
Tube inner nozzle snaps	Low tyre inflation pressure	Inflate the tyres to the right pressure
Excessive wear at tread centre	Excessive tyre inflation pressure	Inflate the tyre to the right pressure
Tyre wears in batches	Defective tyre	Change the tyre
	Frequent sudden braking	Avoid sudden braking
	Defective suspension	Check and rectify

WORKSHOP MANUAL BULLET

COMPLAINT: BRAKE LESS EFFECTIVE

CAUSES	REMEDIES
<ul style="list-style-type: none"> Excessive clearance between brake shoe and drum Oily shoes Glazed shoes and drum Worn out brake shoes Worn out drum Bent back plate Misaligned brake shoe in drum Stuck brake cam 	<ul style="list-style-type: none"> Adjust the brake Replace shoes Remove the glaze with emery paper Replace brake shoes Replace the drum Replace back plate

COMPLAINT: BRAKE BINDING

CAUSES	REMEDIES
<ul style="list-style-type: none"> Brake shoe return spring broken/weak Too tight brake adjustment Jammed cams Brake pedal jam Bent brake rod 	<ul style="list-style-type: none"> Replace the spring Adjust the brakes correctly Lubricate the cams Lubricate Straighten the brake rod

COMPLAINT: BRAKE SQUEAKING

CAUSES	REMEDIES
<ul style="list-style-type: none"> Dust in brake drum Glazed brake shoes / drum Bent back plate Water on brake shoes Misaligned wheel Hard brake shoe linings Totally worn out shoes 	<ul style="list-style-type: none"> Clean the brake drum Roughen the shoe face/drum face Change the plate Apply the brake several times Align the wheel Replace the shoe linings Replace the shoes

WORKSHOP MANUAL BULLET

COMPLAINT: FRONT FORK HITTING NOISE

CAUSES	REMEDIES
Insufficient oil in the fork (hits at the end of the compression stroke)	Top up the oil level
Weak coil springs (hits at the end of compression stroke)	Replace springs with new ones
Worn out spring stud (hits at the end of expansion stroke)	Replace it with new
Loose main tube fitment	Tighten the main tubes

COMPLAINT: WHEEL WOBBLING

CAUSES	REMEDIES
Loose wheel axle nut	Tighten the nuts
Loose spokes	True the wheels
Bent wheel rim	Replace the wheel rim
Re-treaded tyre	Replace with new tyre
Loose steering adjustments	Adjust steering properly
Worn out chain stay pivot bushes	Change the bushes
Loose wheel bearing	Change the wheel bearing

WORKSHOP MANUAL BULLET

COMPLAINT: MOTORCYCLE PULLING TO ONE SIDE

CAUSES	REMEDIES
Low tyre inflation pressure Too tight steering adjustment Worn out steering race / balls Bent front fork main tube Unequal tightening of the main assembly tubes into head bracket Weaker front fork spring in one leg Unequally adjusted rear shock absorber adjusting cams	Inflate it to the right pressure Adjust the steering to proper play Replace the worn out parts Replace the main tube Tighten the main tubes equally Replace springs with new Adjust both side adjusting cams equally

COMPLAINT: BATTERY DISCHARGES FAST

CAUSES	REMEDIES
Lower electrolyte level Shorting in the DC circuit Internal shorting in battery Sulphated or hydrated plates Over charging causing shedding and buckling Lower magneto output (voltage) Topping up with acid or tap water Faulty rectifier Excessive electrical load Loose/covered battery terminals Faulty initial charging	Top up with distilled water Check and correct Replace the battery Replace the battery Replace the battery Check and rectify Always top up with distilled water Replace rectifier Reduce the load Clean and tighten the terminals Provide proper initial charging

WORKSHOP MANUAL BULLET

COMPLAINT: DIM HEAD LIGHT

CAUSES	REMEDIES
Loose joints /earth connection Poor quality bulb	Tighten them Replace them with genuine bulbs
Run down battery Higher voltage bulb	Recharge battery Replace with right voltage bulb
Lower wattage bulb Faded reflector Incorrect focusing	Use right wattage bulb Change reflector Adjust focus of the light

COMPLAINT: FREQUENT BULB FUSING

CAUSES	REMEDIES
Poor quality bulb Use of lower voltage bulb Defective voltage regulator (AC/DC)	Fit genuine bulbs Use bulbs as per specification Replace regulator

WORKSHOP MANUAL BULLET

BULLET 350 CC/500 CC - TORQUE VALUES

ENGINE

ITEM	Kg-m	LB-inch
Rocker Bearing Stud Nut (3/16")	1.30	112.0
Crank Pin Nut (7/8")	13.80	1200.0
Timing Shaft Nut (3/4")	9.20	800.0
Cylinder Head Nut (5/6")	3.30	285.0
Crankcase Joint Nut (M6 1/4")	0.90	78.0
Crankcase Joint Nut (M8 5/16")	1.10	95.0
Gearbox End cover Bolt (1/4")	1.00	85.0
Alternator Nut (Rotor) (9/16")	5.50	475.0
Clutch Mounting Nut (9/16")	5.50	475.0
Main Shaft Nut In Gear Box (5/8")	6.50	565.0
Rocker Box Stud nut	1.45	125.0
Oil feed and Return Filter Assy.	3.00	260.0
Rocker Oil Pipe Banjo Union	1.00	85.0
Rocker Oil Screwed Bush	1.60	138.0
Oil Feed Plug	1.60	138.0
Oil Cleaner Cap Nut	1.40	120.0
Chain case Front att. nut	1.40	120.0

CHASSIS

Frame Stud Nut-Gear Box (1/2")	3.20	277.0
Front Engine Plate Stud Nut (1/2")	3.20	277.0
Rear Engine Plate Stud Nut (Bot.) (3/8")	2.00	175.0
Rear Brake Cam Lever Nut (7/15")	2.00	175.0
Chainstay Stud Nut (1/2")	3.50	300.0
Front Fork End Cap Nut (5/16")	1.30	112.0
Rear Wheel Lock Nut (M22)	7.50	650.0
Rear Wheel Spindle Castle Nut (M16)	6.50	565.0
Rear Shock Absorber Upper (3/8")/Lower Nut (3/8")	2.50	215.0
Front Mudguard Stay Screw Nut (1/4")	0.30	25.0
Front Engine Plate Stud Nut (M8)	1.50	130.0
Front Mudguard Stay Stud Nuts (5/16")	1.20	104.0
Handle Bar Clip Bolt (5/16")	3.30	286.0
Handle Bar Clip & Seat Stud Nuts (5/16")	2.40	208.0
Main Footrest Nuts (3/8")	1.20	104.0
Coil Fixing Bolt and Nuts (M6)	0.45	40.0
Regulator Fixing Nut (M6)	0.45	40.0
Rear Mudguard Carrier Stud Nut (Top) (3/8")	2.00	175.0
Rear Mudguard Carrier Stud Nut (Bottom) (7/16")	2.50	216.0
Rear Engine Plate Stud Nut (M8)	1.50	130.0
Eye Bolt Stud Nut (5/16")	1.50	130.0
Tank Fixing Nut (3/8")	1.60	140.0



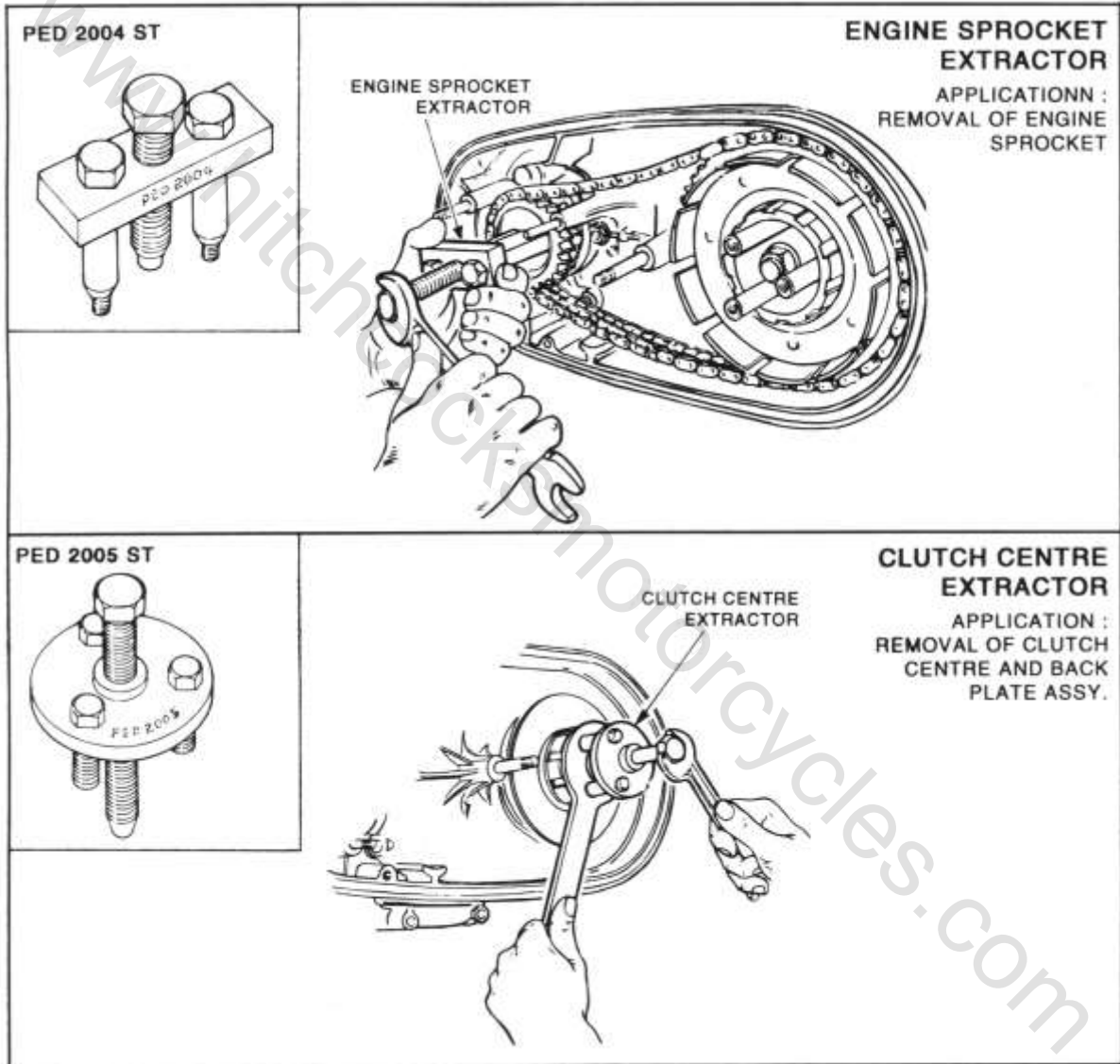

WORKSHOP MANUAL BULLET

SPECIAL TOOLS LIST



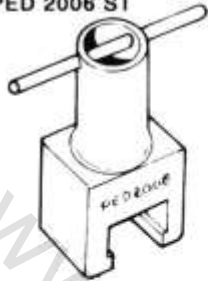
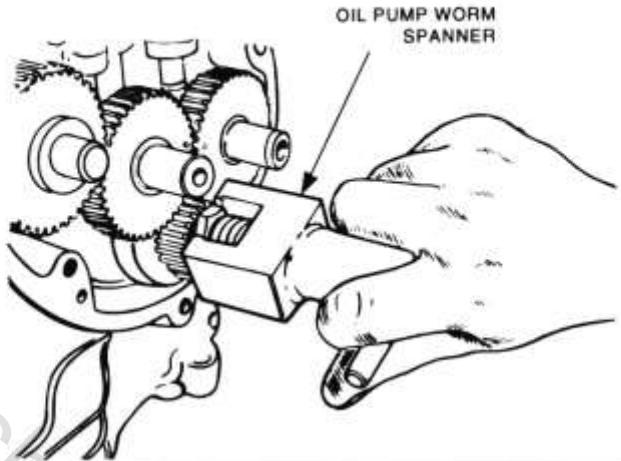

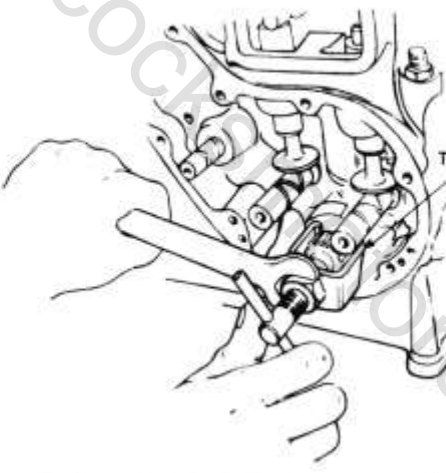
COMMON FOR
350cc and 500cc

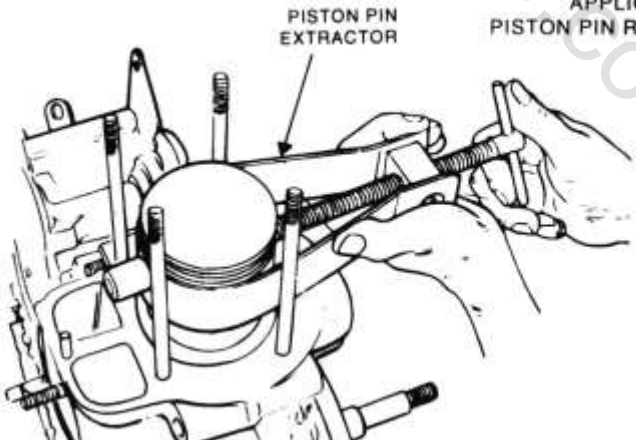

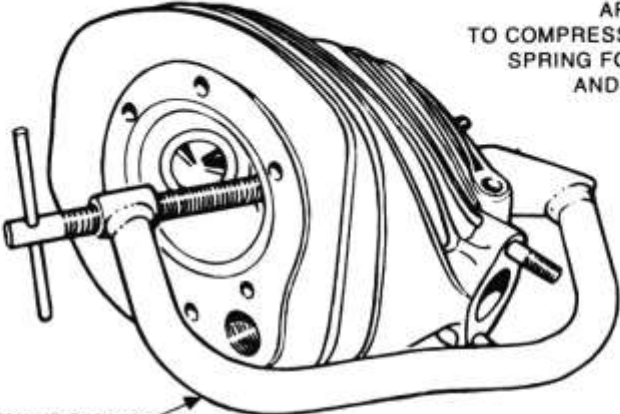

WORKSHOP MANUAL BULLET

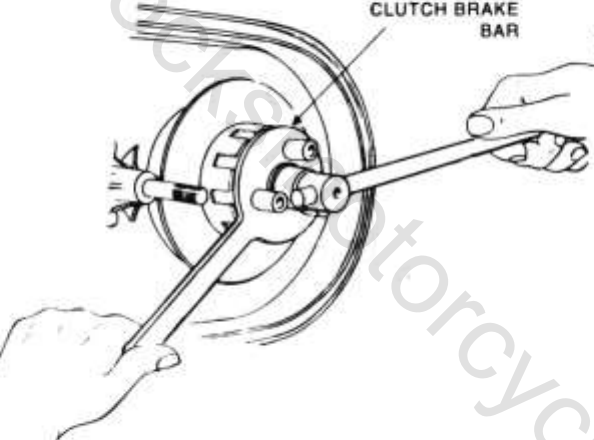
<p>PED 2006 ST</p> 	<p>OIL PUMP WORM SPANNER</p> <p>APPLICATION : REMOVAL AND FITMENT OF OIL WORM NUT</p>  <p>OIL PUMP WORM SPANNER</p>
<p>PED 2013 ST</p> 	<p>TIMING PINION EXTRACTOR</p> <p>APPLICATION : REMOVAL OF TIMING PINION</p>  <p>TIMING PINION EXTRACTOR</p>
<p>PED 2017 ST</p> 	<p>PISTON PIN EXTRACTOR</p> <p>APPLICATION : PISTON PIN REMOVAL</p>  <p>PISTON PIN EXTRACTOR</p>

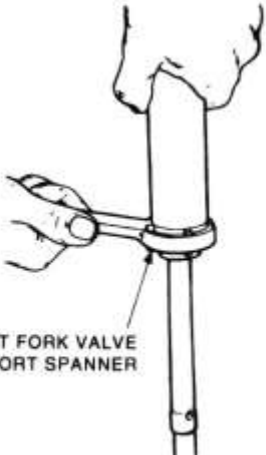

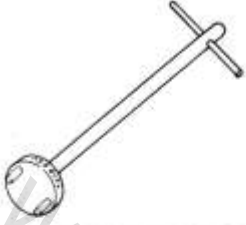
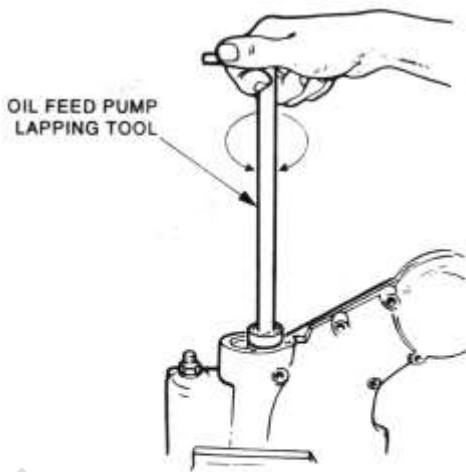
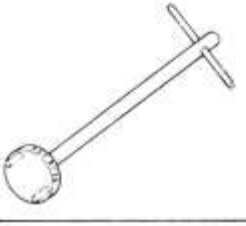

WORKSHOP MANUAL BULLET

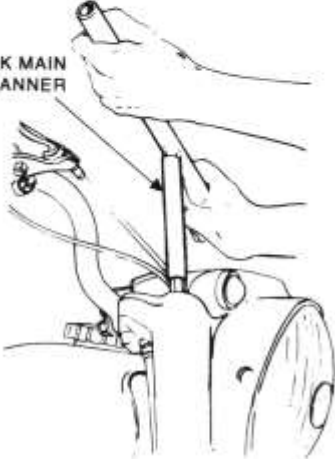
<p>PED 2018 ST</p> 	<p>VALVE SPRING COMPRESSOR</p> <p>APPLICATION : TO COMPRESS THE VALVE SPRING FOR REMOVAL AND FITMENT OF VALVE</p>  <p>VALVE SPRING COMPRESSOR</p>
<p>PED 2025 ST</p> 	<p>CLUTCH BRAKE BAR</p> <p>APPLICATION : HOLDING THE CLUTCH CENTRE AND BACK PLATE ASSY.</p>  <p>CLUTCH BRAKE BAR</p>
<p>PED 2026 ST</p> 	<p>FRONT FORK VALVE PORT SPANNER</p> <p>APPLICATION : REMOVAL AND FITMENT OF VALVE PORT</p>  <p>FRONT FORK VALVE PORT SPANNER</p>



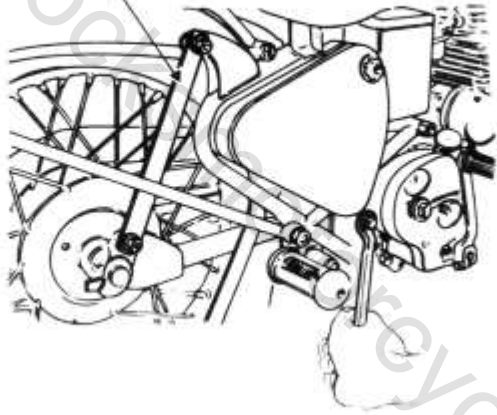

WORKSHOP MANUAL BULLET

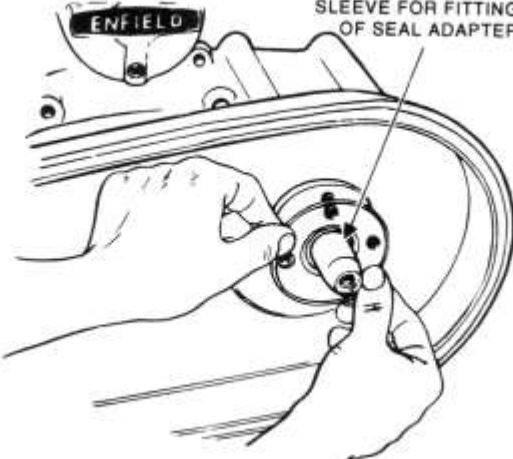
<p>PED 2034 ST</p> 	<p>OIL FEED PUMP LAPPING TOOL</p> <p>APPLICATION : LAPPING FEED PUMP DISC</p> 
<p>PED 2035 ST</p> 	<p>OIL PUMP LAPPING TOOL (RETURN)</p> <p>APPLICATION : LAPPING RETURN PUMP DISC</p> 
<p>PED 2036 ST</p> 	<p>FRONT FORK MAIN TUBE SPANNER</p> <p>APPLICATION : LOOSENING AND TIGHTENING OF FRONT FORK MAIN TUBE</p> 

WORKSHOP MANUAL BULLET

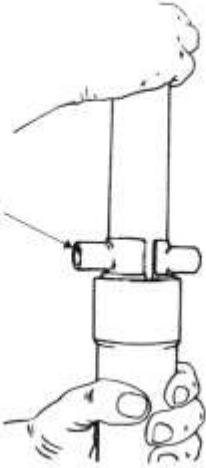
<p>PED 2040 ST</p> 	<p>TAPPET GUIDE EXTRACTOR</p> <p>APPLICATION : REMOVAL OF TAPPET GUIDE</p> 
<p>PED 2044 ST</p> 	<p>GUAGE FOR TIGHTENING CHAIN STAY</p> <p>APPLICATION : ALIGNMENT OF CHAIN STAY WHILE TIGHTENING</p> 
<p>PED 2074 ST</p> 	<p>SLEEVE FOR FITTING OF SEAL ADAPTER</p> <p>APPLICATION : FOR GUIDING CHAIN CASE OIL SEAL ADAPTER</p> 

WORKSHOP MANUAL BULLET

<p>PED 2076 ST</p> 	<p>FRONT FORK OIL SEAL EXPANDER</p> <p>APPLICATION : FOR EXPANDING OIL SEAL WHILE INSERTING MAIN TUBE INTO BOTTOM TUBE OF FRONT FORM</p>  <p>FRONT FORK OIL SEAL EXPANDER</p>
<p>PED 2077 ST</p> 	<p>MANDREL FOR OIL SEAL</p> <p>APPLICATION : FITMENT OF OIL SEAL IN FRONT FORK BOTTOM TUBE</p>  <p>MANDREL FOR OIL SEAL</p>
<p>PED 2078 ST</p> 	<p>SLEEVE FOR REMOVING FRONT FORK OIL SEAL</p> <p>APPLICATION : REMOVAL OF OIL SEAL FROM FRONT FORK BOTTOM TUBE</p>  <p>SLEEVE FOR REMOVING FRONT FORK OIL SEAL</p>

WORKSHOP MANUAL BULLET

Metric conversion tables

Inches	Decimals	Millimetres	Millimetre. to Inches		Inches to Millimetres	
			mm	Inches	Inches	mm
1/64	0.0156265	0.3969	0.01	0.00039	0.001	0.0254
1/32	0.03 125	0.7937	0.02	0.00079	0.002	0.0508
3/64	0.046875	1.1906	0.03	0.00118	0.003	0.0762
1/16	0.0625	1.5875	0.04	0.00157	0.004	0.1016
5/64	0.78125	1.9844	0.05	0.00197	0.005	0.1270
3/32	0.09375	2.3812	0.06	0.00236	0.006	0.1524
7/64	0.109375	2.778 1	0.07	0.00276	0.007	0.1778
1/8	0.125	3.1750	0.08	0.00315	0.006	0.2032
9/64	0.140625	3.5719	0.09	0.00394	0.009	0.2286
5/32	0.15625	3.9687	0.1	0.00394	0.01	0.254
11/64	0.171875	4.3656	0.2	0.00787	0.02	0.508
3/16	0.1875	4.7625	0.3	0.01181	0.03	0.762
13/64	0.203125	5. 1594	0.4	0.01575	0.04	1.016
7/32	0.21875	5.5562	0.5	0.01969	0.05	1.270
15/64	0.234375	5.9531	0.6	0.02362	0.06	1.524
1/4	0.25	6.3500	0.7	0.02756	0.07	1.778
17/64	0.265625	6.7469	0.8	0.3150	0.08	2.032
9/32	0.28125	7.1437	0.9	0.3543	0.09	2.286
19/64	0.296875	7.5406	1	0.03937	0.1	2.54
5/16	0.3125	7.9375	2	0.07874	0.2	5.08
21/64	0.328125	8.3344	3	0.11811	0.3	7.62
11/32	0.34375	8.73 12	4	0.15748	0.4	10.16
23/64	0.359375	9.1281	5	0.19685	0.5	12.70
3/8	0.375	9.5250	6	0.23622	0.6	15.24
25/64	0.390625	9.92 19	7	0.27559	0.7	17.78
13/32	0.40625	10.3187	8	0.31496	0.8	20.32
27/64	0.421875	10.7156	9	0.35433	0.9	22.86
7/16	0.4375	1 1. 1 125	10	0.39370	1	25.4
29/64	0.453125	1 1.5094	11	0.43307	2	50.8
15/32	0.46875	1 1.9062	12	0.47244	3	76.2
31/64	0.48375	12.3031	13	0.51181	4	101.6
1/2	0.5	12.7000	14	0.551 18	5	127.0
33/64	0.515625	13.0969	15	0.59055	6	152.4
17/32	0.53125	13.4937	16	0.62992	7	177.8
35/64	0.546875	13.8906	17	0.66929	8	203.2
9/16	0.5625	14.2875	18	0.70866	9	228.6
37/64	0.578125	14.6844	19	0.74803	10	254.0
19/32	0.59375	15.0612	20	0.78740	11	279.4
39/64	0.609375	15.4781	21	0.82677	12	304.8
5/8	0.625	15.8750	22	0.86614	13	330.2
41/64	0.640625	16.2719	23	0.90551	14	355.6
21/32	0.65625	16.6687	24	0.94488	15	381.0
43/64	0.671875	17.0656	25	0.98425	16	406.4
11/16	0.6875	17.4625	26	1.02362	17	431.8
45/64	0.703125	17.8594	27	1.06299	18	457.2
23/32	0.71875	18.2562	28	1.10236	19	482.6
47/64	0.734375	18.6531	29	1.14173	20	508.0
3/4	0.75	19.0500	30	1.18110	21	533.4
49/64	0.765625	19.4469	31	1.220447	22	558.8
25/32	0.78125	19.8437	32	1.25984	23	584.2
51/64	0.796875	20.2406	33	1.29921	24	609.6
13/16	0.8125	20.6375	34	1,33858	25	635.0
53/64	0.828125	21.0344	35	1.37795	26	660.4
27/32	0.84375	21.4312	36	1.41732	27	685.8
55/64	0.859375	21.8281	37	1.4567	28	711.2
7/8	0.875	22.2250	38	1.496 1	29	736.6
57/64	0.890625	22.62 19	39	1.5354	30	762.0
29/32	0.90625	23.0187	40	1.5748	31	787.4
59/64	0.921875	23.4156	41	1.6142	32	812.8
15/16	0.9375	23.8125	42	1.6535	33	838.2
61/64	0.953125	24.2094	43	1.6929	34	863.6
31/32	0.96875	24.6062	44	1.7323	35	889.0
63/64	0.984375	25.0031	45	1.7717	36	914.4

WORKSHOP MANUAL BULLET

www.hitchcocksmotorcycles.com

WORKSHOP MANUAL BULLET

**ELECTRIC
START
AND
5 SPEED
GEARBOX
SUPPLEMENT**

WORKSHOP MANUAL BULLET

PRINCIPLE OF ELECTRIC START.

There is a 'Starter motor assembly' which is connected to the 'engine sprocket' on the crankshaft, through a series of gears and a 'Sprag clutch'. This starter motor is driven by a powerful 12V 14 Ah battery.

'Sprag clutch' is a mechanism which allows the starter motor torque to pass through it to the crankshaft, when the crankshaft rpm is less than the motor rpm, but starts to slip once the crankshaft rpm is higher than the starter motor rpm. Thus, once when the engine is started, the starter motor's torque will have no effect on the crankshaft.

Moreover, when the engine is started, the 'auto starter cut off', if fitted cuts off the battery connection to the starter motor, so that, even if accidentally the engine starter switch is pressed, the starter motor is not activated. This is to prevent possible damage to the motor and gears.

The battery is connected to the starter motor through the 'relay starter switch'. A conventional switch will not be in position to withstand very high current and hence relay starter switch is used.

Working

When the Ignition switch is switched 'ON', an electric supply from the relay starter is made available at the engine starting switch on the RH side of Handlebar. When this is pressed, the relay starter is activated and it connects the battery with the starter motor thus starting the engine.

WORKSHOP MANUAL BULLET

TROUBLE SHOOTING

a. Starter motor not working

Start the engine through kick-starter. If the engine does not start check:

- | | |
|---|---|
| 1) Loose connections | Tighten |
| 2) Low battery voltage | Check specific gravity. Recharge if necessary |
| 3) Starter motor body is properly earthed | Earth properly |
| 4) Stuck starter relay | Replace |
| 5) Blown fuse | Replace |
| 6) Faulty Starter motor | Check/Replace |

b. Starter motor continuously running

- | | |
|---------------------------|-------------------|
| 1) Shorting starter relay | Replace |
| 2) Battery cells shorting | Check and correct |

Caution:

Always de-clutch before starting

WORKSHOP MANUAL BULLET

Technical Specifications

General Specifications		
1	System 12V AC/DC with Electric Start	12v AC/DC with electric start
2	Battery 12V 14 Ah	12V 14Ah
3	Battery Charging 1.4 - 1.5 Amps for 10 - 12 hours	1.4 – 1.5 Amps for 10-12 hours
4	Starter Motor 0.9 Kw (Make - Denso)	0.9Kw (make Denso)
5	Solenoid Switch Magnetic Relay type	Magnetic relay type
6	Head Lamp 12V 45/40 W	45/40w
7	Tail/Brake Lamp 12V 21/5W	21/5w
8	Pilot Lamp 12V 2W	3.4w
9	Speedo Lamp 12V 3.4W	2w
10	Neutral Indicator 12V 3.4W	3.4w
11	High Beam 12V 3.4W	3.4w
12	Turn Signal Indicator 12V 3.4W	3.4w
13	Turn Signal lamp 12V 10W	10w
14	Horn 12V 2.5A	2.5Amp
15	Special feature Auto starter cut off	Auto starter cut off

Battery Specifications		
1	Type	Exide 12 Volts
2	Capacity	14 Ah (at 10 Hr rate)
3	Charging Current	1.4 Amps
4	Specific gravity of Acid	1.240 at 27°C
5	Grade of Acid	"Battery Grade" Sulphuric Acid
6	Max Temperature during Charging	50° C
7	Initial Charging duration	10 hours

Tightening Torque

	Description	Kg-M	N-M
1	Drive cover screws	0.61	6.1
2	Starter Motor	1.4	14
3	Chaincase inner	3.55	35.5

WORKSHOP MANUAL BULLET

DISMANTLING AND ASSEMBLING PROCEDURE

Dismantling Procedure

Remove the 2 starter motor fixing allen screws and pull out the starter motor from the drive cover.

Caution: Do not rotate the motor while removing, as this action will damage the 'O' ring.

2. Remove the left hand side footrest
3. Loosen the chaincase front half mounting nut to drain the oil from the chaincase, and remove the chaincase front half
 - Remove the alternator rotor sleeve nut and the stator holding nuts
 - Pull out the stator and rotor.
 - Remove the spacers
 - Remove the woodruff key from the crankshaft
 - Remove the chain tensioner pad nut, and slide out the tensioner along with washers
 - Remove the clutch cap screws along with washers, by loosening them alternatively
 - Remove the clutch cap & and remove the clutch springs
 - Remove the front plate
 - Pull out the clutch pad and take out the clutch plates
 - Remove the clutch center retaining spring
 - Using special tool 2004 to pull out the engine sprocket along with the clutch drum and primary chain
 - Hold the clutch center with special tool 2025 and remove the clutch center holding nylock nut
 - Hold the clutch center with special tool 2025 and pull out clutch center using special tool 2005
4. Remove the 3 socket head screws and remove the chaincase back half assembly with the drive cover.
5. Keep the chaincase back half assembly in a work table and remove the 5 drive cover fixing screws
6. Remove the drive cover assembly.

Note: Rotate the idler gear while pulling drive cover for ease of removing.

7. Remove the gasket from the chaincase back half.
8. Pull out the idler gear
9. Take out the sprag clutch assembly
10. Remove the needle roller cage from the clutch driven gear
11. Hold the clutch driven gear in the left hand and then remove the clutch driving gear assembly from the clutch driven gear by rotating it in an anti clockwise direction.
12. Remove the circlip from the clutch driving gear assy.
13. Take out the sprag clutch.

WORKSHOP MANUAL BULLET

Assembling Procedure continued -

1. Assemble the sprag clutch inside the clutch driven gear, with its wide flanged face facing the clutch driving gear. Ensure that all sprags are seated inside the clutch driven gear.
2. Fit circlip on the clutch driven gear.
3. Assemble the clutch driving gear assembly onto the clutch driven gear with the sprag clutch, by rotating it in anti clockwise direction. The clutch driving gear assembly should freely rotate in an anti clockwise rotation - when seen from clutch driving gear.

Caution: Do not press the clutch driving gear assy onto the clutch driven gear. This may damage the sprags.

4. Place the sprag clutch assembly in the chaincase back half, with the driven gear facing starter motor.
5. Fit the idler gear in the bush provided in the chaincase back half with the big gear facing the starter motor.
6. Align the sprag clutch assembly bore with the bush in the chaincase rear half.
7. Place the needle roller cage in the bore of the clutch driven gear.
8. Apply grease on the chaincase back half and fix the gasket.
9. Assemble drive cover assembly by aligning the dowel and the spindle.
10. Fix the 5 drive cover mounting allen screws and tighten them uniformly.
11. Assemble the chaincase back half with the drive cover on the crankcase
12. Fit the clutch center assembly on to the gearbox main shaft.
13. Align the tooth profile of the clutch driving gear and the clutch driven gear and assemble the sprocket gear and clutch drum assembly with the duplex chain.
14. Assemble the chain tensioner pad assembly and adjust the duplex chain tension.
15. Fit the clutch center retaining spring.
16. Assemble the clutch plates.
17. Fit the clutch pad with bearing washer.
18. Fix the front plate.
19. Position the clutch springs and fix the clutch cap.
20. Fit the clutch cap screws.
21. Fit the wood ruff key on the crank shaft.
22. Fit the alternator rotor and tighten the sleeve nut.
23. Fit the 3 alternator stator spacers.
24. Assemble the stator and tighten the 3 nuts.
25. Assemble the chaincase front half.
26. Fill up the oil in the chaincase to the correct level.
27. Assemble the left hand footrest.
28. Crank the engine and assemble the starter motor from the timing cover side, ensuring correct engagement of the starter motor teeth with the idler gear.
29. Fix the 2 starter motor mounting allen screws along with the washers.

Caution: Do not rotate the starter motor while assembling, as this will damage the `o' ring.

WORKSHOP MANUAL BULLET

Battery Charging Procedure

Preparation Of Electrolyte

Add Sulphuric Acid to distilled water. Do not add water to acid - It may explode.

Stir well and check the Specific gravity of the electrolyte and add sulphuric acid until the specific gravity becomes 1.240.

Cool the Electrolyte below 30°C. Remove the short sealed plastic tube and replace it with long exhaust tube. Remove the filling caps and fill the battery cells with the electrolyte prepared up to the maximum level

Soaking

Allow the battery to soak and cool for 30 to 60 minutes. If the electrolyte level drops, top up with electrolyte.

Steps for initial battery charging

Connect the battery to a constant current charger. Apply 1.4 Amps current for 10 hours. Ensure the temperature of the electrolyte does not exceed 50°C. Check the electrolyte level and concentration every hour. Add distilled water if required (Do not use acid). Indication for fully charged condition - All cells gas freely - 3 consecutive reading shows specific gravity of 1.24 - With charger disconnected, the terminal voltage should be 13.2v.

Recharge the battery when:

- Battery remains unused for more than 3 weeks
- Specific gravity of battery drops below 1.2

WORKSHOP MANUAL BULLET

Battery Maintenance

Keep the battery clean and dry
Never overcharge the battery
Check for cracks and leakages
Check electrolyte level every 3 weeks and add distilled water if required
Keep the battery away from sunlight and fire
Apply petroleum jelly on battery terminals

Maintenance of Battery while not in use

Remove the battery from motorcycle
Maintain the electrolyte level at the "Upper level"
Charge the battery once a month
Store the battery in a cool dry place
Keep the battery away from rain, moisture, dew and sunlight

WORKSHOP MANUAL BULLET

Do's and Don'ts

Do's

- While preparing the electrolyte
 - * Add sulphuric acid to distilled water and not vice versa
 - * Use proper gloves and aprons
- While Battery is charging
 - * Apply only 1.4 Amps current for 10 hours
 - * Ensure temperature of electrolyte does not exceed 50°C
 - * Add distilled water if required (Do not use Acid)
 - * Ensure all the battery caps are removed
- After Charging
 - * Keep the battery clean and dry
 - * Keep the battery away from sunlight and fire
 - * Apply petroleum jelly on the battery terminals
 - * Store the battery in a cool dry place
- Check the battery for electrolyte level periodically and top up with distilled water only.
- For longer battery life, de-clutch before starting
- If the battery is weak, start through the kick starter and do not try to start with the electric starter
- Service your bike only at authorised service stations

Don'ts

- Never overcharge the battery
- Never spray water with great force on the starter motor, tool box and other electrical parts
- Do not carry out any repairs on the starter motor, auto starter cut off and relay starter, or the clutch mechanism.

WORKSHOP MANUAL BULLET

Electric Start - ELECTRICAL COMPONENTS INSPECTION

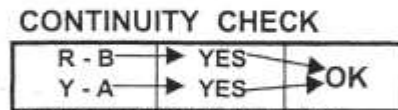
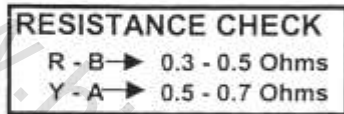

IF NO THEN OPEN CIRCUIT.
CHECK & CORRECT

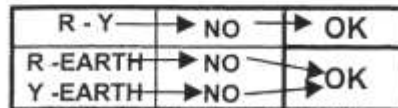

IF YES THEN SHORT CIRCUIT.
CHECK & CORRECT

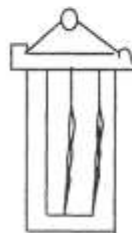
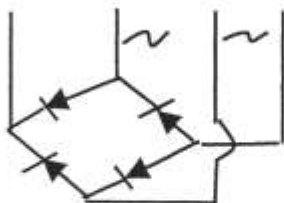
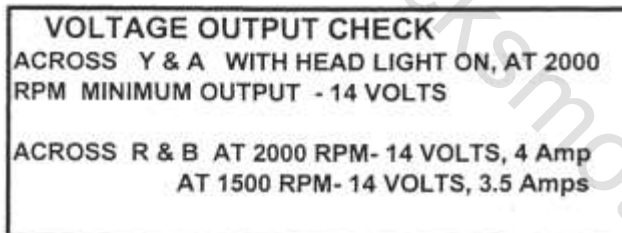

WORKSHOP MANUAL BULLET

Five Speed Gearbox—Specifications and Features

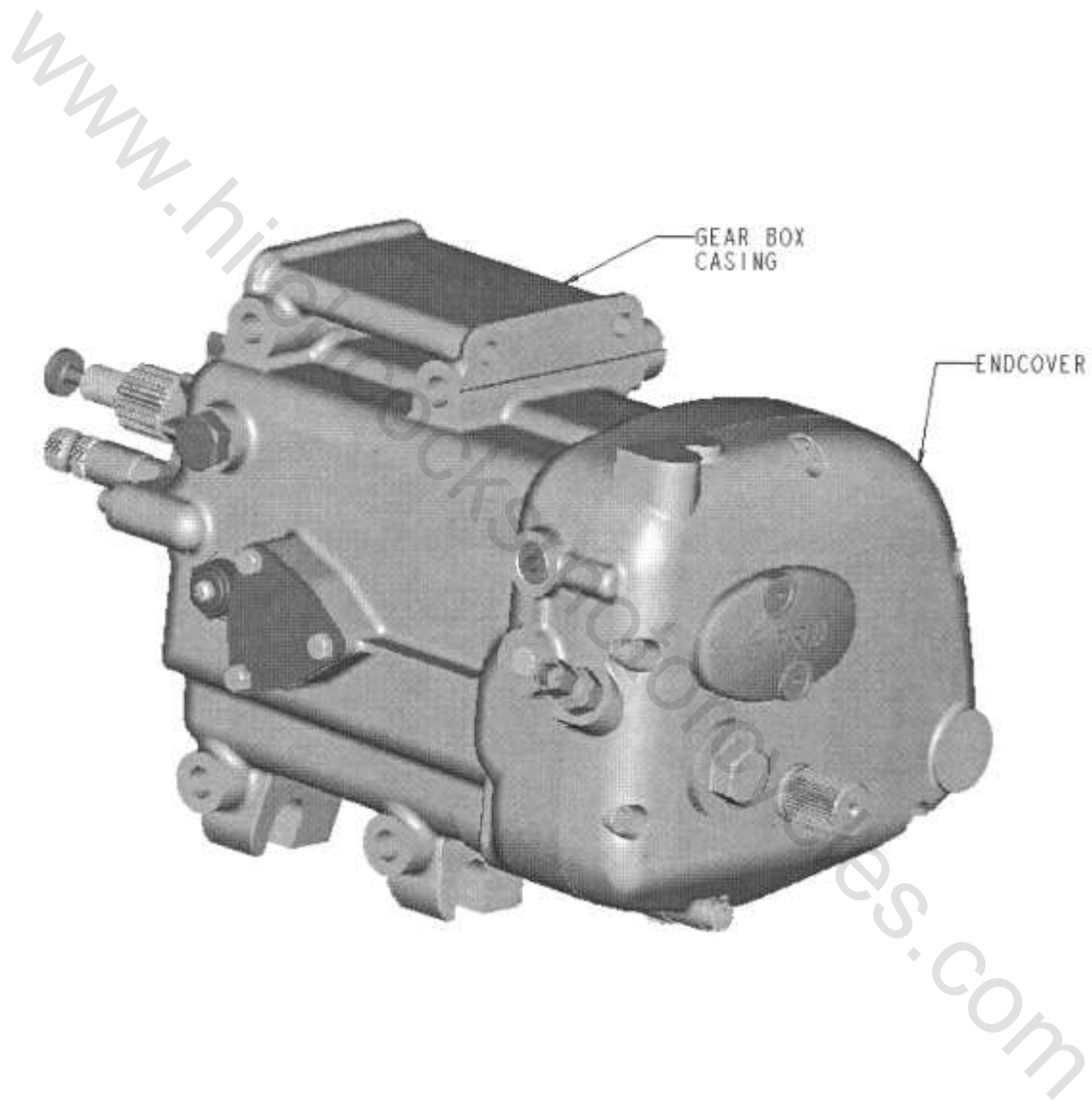

WORKSHOP MANUAL BULLET

Technical Specifications:

S.NO	DESCRIPTION	SPECIFICATION
1	Gearbox type	Constant mesh gearbox
2	Gear shifting control system	Gear shift lever – foot operated (heel and toe type)
3	Gear shifting pattern	1 down and 4 up
4	For neutral finding	Neutral indicating light in instrument panel
5	Lubricant oil	450ml. Of EP90 gear oil
6	Gear ratios	
	1 st Gear	3.063:1
	2 nd Gear	2.013:1
	3 rd Gear	1.522:1
	4 th Gear	1.212:1
	5 th Gear	1.00:1
	Primary ratio	2.24:1

Constructional differences between 4 and 5 speed gearboxes

No	5 Speed	4 Speed	Remarks
1	Cam plate/selector fork/index pawl mechanism for gear change	Ratchet/selector fork/plunger mechanism for gear change	Provides smoother operation and positive lock
2	Carrier plate inside the gearbox casing and end cover	End cover butted with gearbox casing and end cap	Makes assembly easier and simple

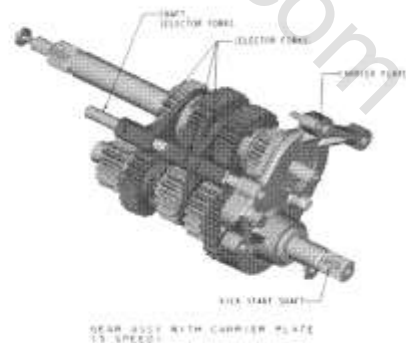
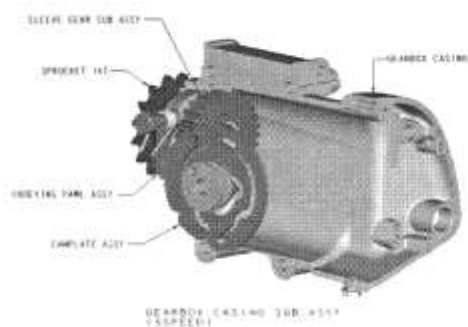

WORKSHOP MANUAL BULLET

3	Fully splined shafts/gears	Stub tooth shafts/gears	Provides better torque carrying capacity and less lash
4	Use of needle roller bearings in kick start shaft, layshaft, and sleeve gear	Use of bushes in kick start shaft and lay shaft	Improves reliability and ensures smooth running
5	Neutral switch contact - operation on the left	Separate lever for neutral operation	Better convenience while shifting gears
6	Innovative three ball operating clutch mechanism mounted with end cover	Lever type clutch operating mechanism mounted with end cap	Improves efficiency and provides smoother operation of clutch

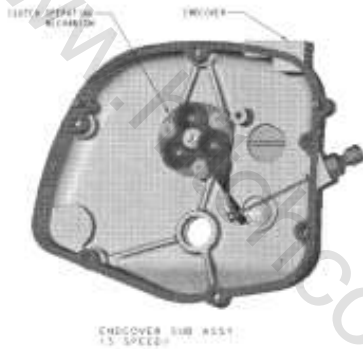

7	Heel & toe lever arrangement for Upward/Downward gear shifting	Only toe lever arrangement for unidirectional shifting	Provides greater comfort in both the directions gear shifts
---	--	--	---

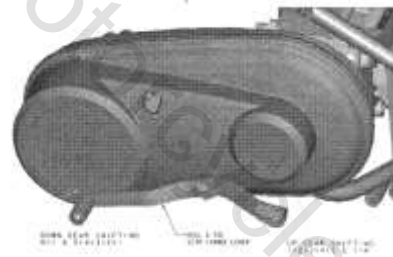

8	LH shifting shaft guided through the crankcase and chaincase	Linkages passed across the frame	Less number of linkages gives better efficiency of shift
---	--	----------------------------------	--

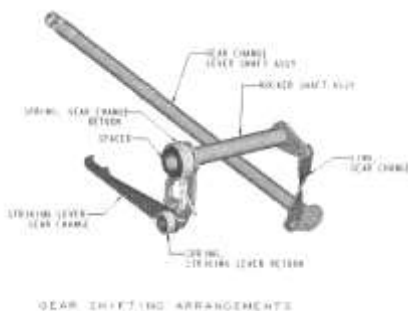

WORKSHOP MANUAL BULLET

Advantage of 5 speed gearbox:

1. Closely packed gear ratios gives improved vehicle acceleration and gradeability and an overall better driveability .

Gear ratio comparison:

5speed		4speed	
Top gear	1:1	1:1	Top gear
4 th gear	1.212:1	1.364:1	3 rd gear
3 rd gear	1.522:1	1.842:1	2 nd gear
2 nd gear	2.013:1	2.778:1	1 st gear
1 st gear	3.063:1		

2. Improved contact ratios of gears, resulting in increased durability, smooth running and lower noise

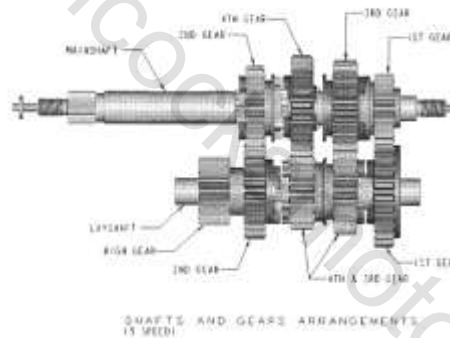

3. Improved durability and smoothness of the gear shift arrangement due to the complete arrangement
4. Internal linkage for LH gear shifting-improves the smoothness and efficiency in gear shifts
5. Less adjustment required during assembly in clutch. Easily accessible User-Friendly arrangement for adjustment of clutch on the road
6. Replacement of neutral lever by contemporary neutral indicator switch
7. Interchangeability of current gearbox in any of the Royal Enfield bikes with minimal changes
8. Use of oil instead of grease improves lubrication, reduces complexity while servicing, like all contemporary bikes results in extended life for gears and bearings.
9. Use of heel & toe lever for gear shifting for better ergonomics and ease of shifting.

Recommended Service limits for oil

3 The lubricant oil should be drained and refilled at the first service that is after 500miles (800 kms).

4 The lubricant oil should subsequently be drained after every 12,000 kms

WORKSHOP MANUAL BULLET

Regular Service tools needed for 5 speed gearbox:

No	Location	Tools
1	For removal and tightening of the end cover allen screws	5mm allen key
2	For adjustment of the clutch cable screw	Size 10mm open spanner
3	For locking the clutch cable screw	Size 12mm open spanner
4	For removal and tightening of the carrier plate	Size 13mm socket and 'T' lever
5	For removal and tightening of both sides of the mainshaft nuts, clutch center and carrier plate	Size 19mm socket and 'T' lever
6	For removal and tightening of cam plate pivot pin screws	Size 8mm ring spanner
7	For adjusting the clutch screw	sharp small screwdriver and size 10mm ring spanner
8	For removal and tightening of kick-start crank	1/4 BS open spanner
9	For removal and tightening of oil filler plug	3/8 BS open spanner

More images showing Power transfer on different gears Neutral

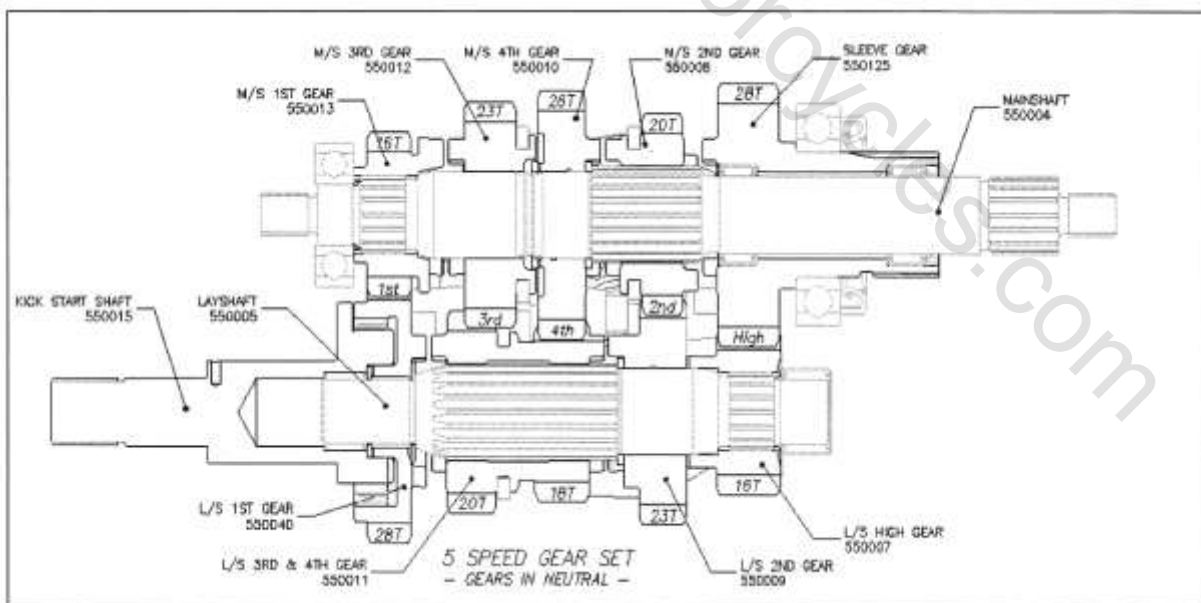

WORKSHOP MANUAL BULLET

1st gear

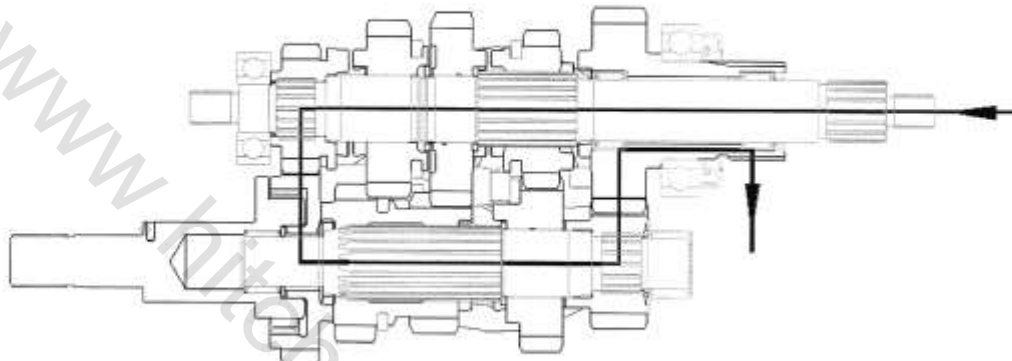

DRIVE THROUGHPUT IN 1st GEAR
 $28/16 \times 28/16 = 3.063:1$

2nd gear

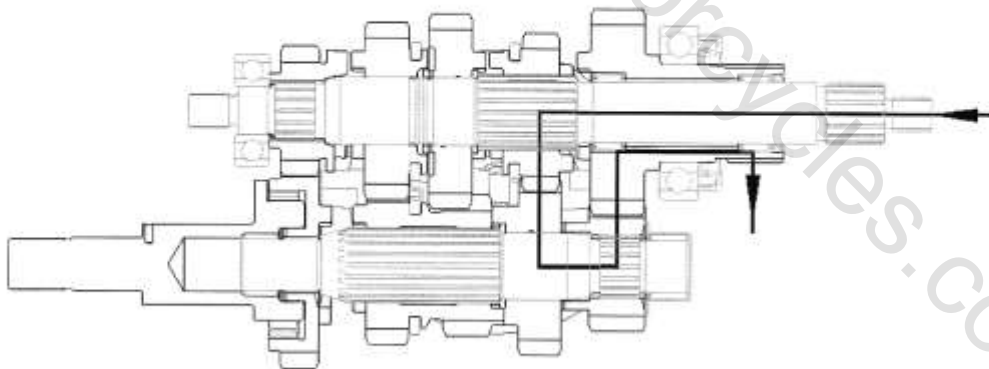

DRIVE THROUGHPUT IN 2nd GEAR
 $23/20 \times 28/16 = 2.013:1$

WORKSHOP MANUAL BULLET

3rd gear

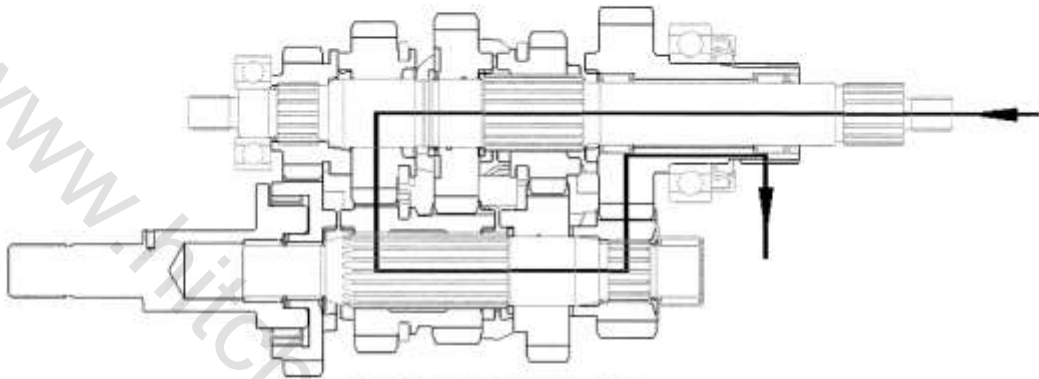

DRIVE THROUGHPUT IN 3rd GEAR
 $20/23 \times 28/18 = 1.522:1$

4th Gear

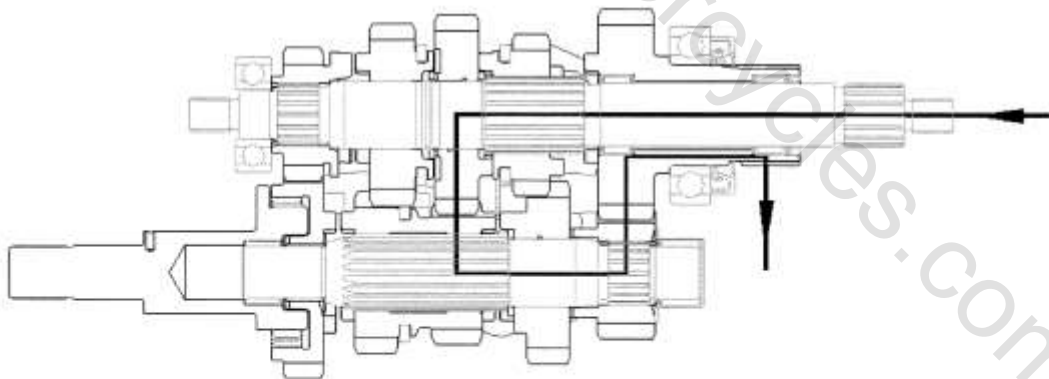

DRIVE THROUGHPUT IN 4th GEAR
 $18/26 \times 28/16 = 1.212:1$

WORKSHOP MANUAL BULLET

Top gear

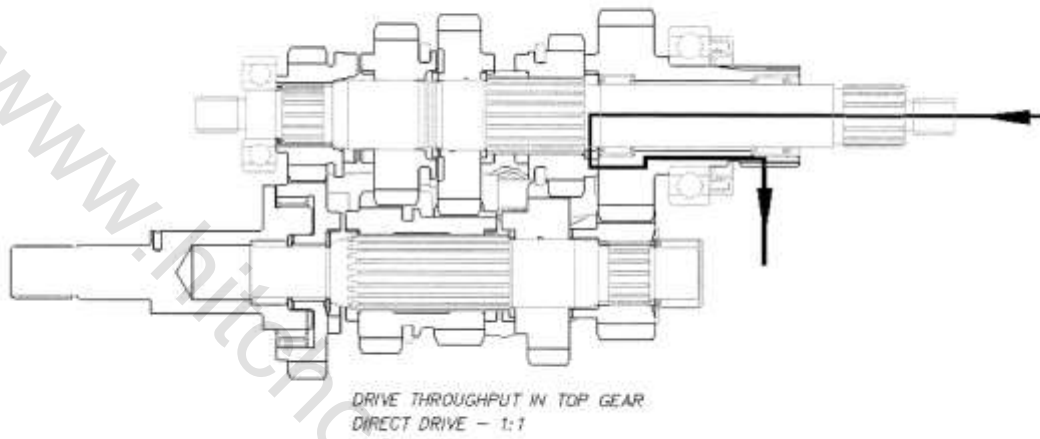

WORKSHOP MANUAL BULLET

Assembly instruction of 5-speed gearbox clutch cable/operating mechanism

COM (Clutch operating mechanism)

A. Mounting clutch operating mechanism.

1. Mount the clutch operating mechanism on the end cover. The adjuster screw should project less than 5mm from sleeve face. This will enable free assembly of the end cover with casing without the screw fouling with the clutch push rod
2. Assemble the end cover with the casing. Remove the inspection cover if already fitted.

B. Adjusting Screw in COM (thrust pin)

3. Loosen the clutch operating mechanism with a ring spanner
4. Adjust the screw (thrust pin) using a screwdriver until it touches the push rod (Zero clearance). Over tightening of the adjuster screw will lead to clutch slip/hard.
5. Tighten the M6 nut while holding the screw in the adjusted position, check for any axial play on the clutch operating mechanism. In case of any play, again readjust the screw. **Never attempt to adjust this clearance by the cable adjustment.**

C. Inserting Cables,

6. Insert the clutch cable adjuster screw to the end cover & clutch cable adjuster gearbox end should reset on M8 nut, which rests on the end cover top face. This will ensure the cable insertion in COM is in fully released condition.
7. Insert inner cable nipple to the clutch lever slot locating it centrally so to ensure locking in the mechanism. Never insert the inner cable freely into the slot & ensure only nipple insertion.
8. Route the clutch cable freely, to avoid sharp bends/turns. Avoid compressing the cable that is near the front petrol tank mounting boss channel. Do not use a strap on the clutch cable at the handle bar side.
9. Insert the other end of the inner clutch cable barrel to the clutch hand lever.
10. Adjust the clutch cable adjuster-gearbox end until the setting of the free play (12mm) at clutch lever on the handlebar
11. Tighten the lock nut on the adjuster screw
12. Fit the inspection cover after properly pressing the gasket & also the fiber washer on the oil filler cap.

WORKSHOP MANUAL BULLET

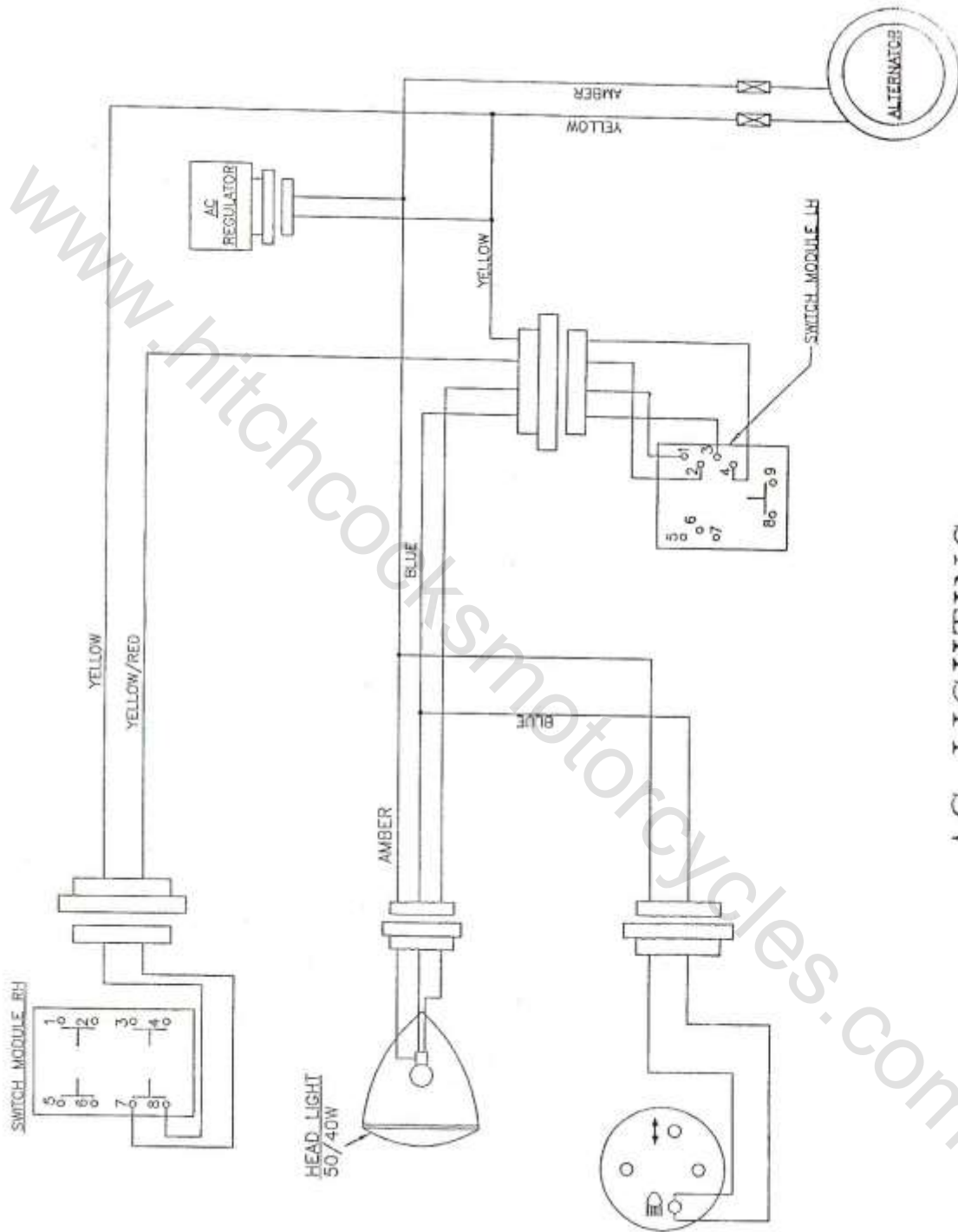

AC LIGHTING

WORKSHOP MANUAL BULLET

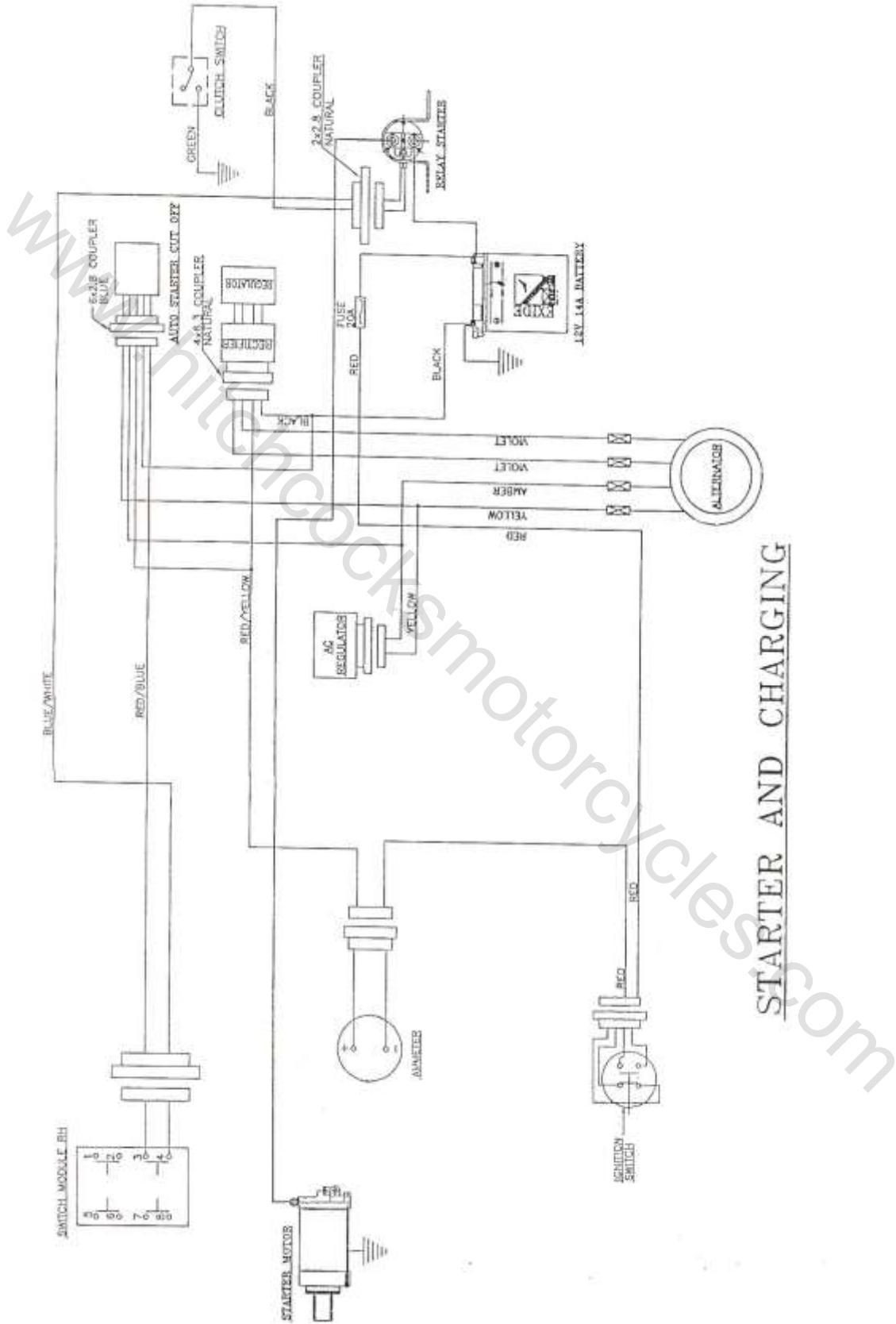

STARTER AND CHARGING

WORKSHOP MANUAL BULLET

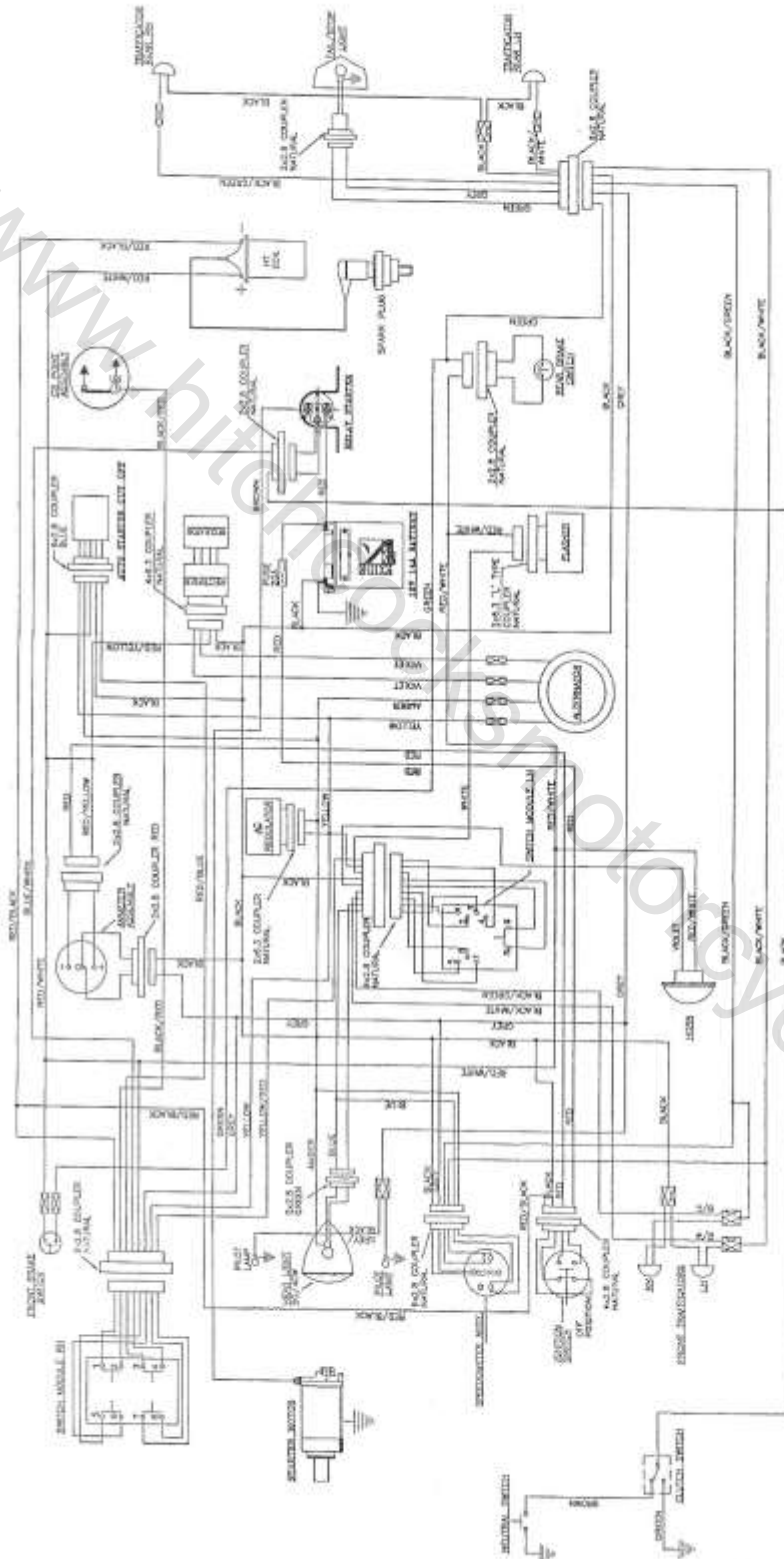

DWG No. 580173/A
FOR UK EXPORT

NOTES

www.hitchcocksmotorcycles.com

NOTES

www.hitchcocksmotorcycles.com

