

WORKSHOP MAINTENANCE MANUAL

FOR THE

ROYAL ENFIELD

**125 c.c. TWO-STROKE
MOTOR CYCLE
MODEL RE**

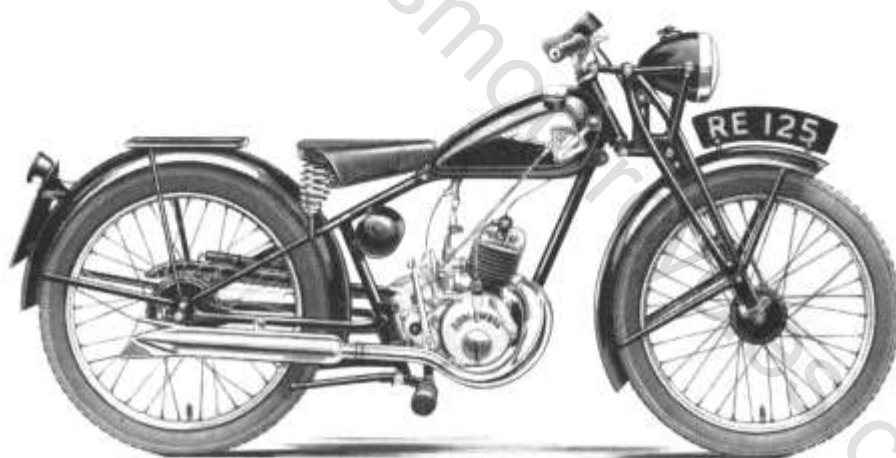

THE ENFIELD CYCLE COMPANY LTD.

HEAD OFFICE AND WORKS: REDDITCH, WORCS.

Telegrams :

“ Cycles, Phone, Redditch.”

Telephone :

Redditch 121 (8 lines).

London Showrooms and Spares Depot :

221 TOTTENHAM COURT ROAD, W.1.

Telephone : MUSEum 3991-2.

ROYAL ENFIELD WORKSHOP MANUAL

CONTENTS

	Para.	Page		Para.	Page
LIST OF ILLUSTRATIONS		3	FRAME AND FORK	37-45	26
ENGINE	1-18	5	Petrol Tank	37	26
Operation	1	5	Gear Control Quadrant	38	26
Decarbonising	2-9	5	Alignment of Wheels	39	26
Removal of Cylinder and Cyl. Head	2	5	Adjustment of Steering Head	40	26
Removal of Piston	3	6	Dismantling and Reassembling		
Removal of Carbon	4	6	Steering Head	41	26
Piston and Rings	5	6	Adjustment of Fork Links	42	27
Big-End Bearing	6	7	Replacing Fork Suspension and		
Small-End Bearing	7	7	Rebound Rubbers	43	27
Decompressor	8	7	Dismantling the Front Fork	44	29
Re-assembly after Decarbonising	9	10	Handlebar Control Levers	45	29
Complete Overhaul	10-18	10	CARBURETTOR	46-51	30
Removal of Engine from Frame	10	10	General Description	46	30
Dismantling the Crankcase	11	10	Construction of Carburettor	47	30
Dismantling the Crankshaft	12	12	Method of Tuning	48	30
Connecting Rod	13	12	Carburettor Troubles	49	31
Big-End Bearing	14	12	Air Cleaner	50	31
Re-assembly of Crankshaft	15	12	Causes of High Petrol Consumption	51	31
Removing and Refitting Crankcase			LIGHTING AND IGNITION SYSTEM	52-72	32
Bearings and Sealing Bushes	16	13	Magneto	52-61	32
Reassembling the Crankcase	17	14	Operation of Magneto	52	32
Replacing Engine in Frame	18	15	Cleaning and Lubrication of Contact		
TRANSMISSION	19-29	16	Breaker Mechanism	53	32
Operation of Gear Box	19	16	Adjustment of Contact Breaker	54	34
Dismantling the Gear Box	20	17	H.T. Cable	55	34
Removal of Gearbox Bearings	21	17	H.T. Connection	56	34
Refitting Gearbox Bearings	22	17	Ignition Timing	57	34
Re-assembly of Gearbox	23	20	Removal and Replacement of Magneto	58	34
Clutch	24, 25	20	Dismantling the Magneto	59	34
Dismantling and Re-assembly of Clutch	24	20	Test and Repair of Magneto	60	34
Adjustment of Clutch Control	25	20	Re-assembly of Magneto	61	35
Chains	26-29	21	Sparking Plug	62	36
Lubrication	26	21	Lighting Circuit	63, 64	36
Tensioning	27	21	Testing	63	36
Limits of Wear	28	21	Lighting Coils, Testing	64	36
Removal, Repair and Replacement	29	21	Headlamp	65-68	36
WHEELS	30-36	22	Removing Lamp and Reflector	65	36
Removal and Replacement	30	22	Setting and Focussing	66	36
Tyres	31	22	Cleaning	67	37
Rims	32	22	Bulbs	68	37
Spokes	33	22	Tail Lamp	69	37
Brakes	34	22	Speedometer Light	70	37
Wheel Bearings	35	22	Parking Battery	71	37
Rear Sprocket	36	25	Lighting Switch	72	37
			LUBRICATION CHART		38
			DATA		39
			INDEX		40

ROYAL ENFIELD WORKSHOP MANUAL

LIST OF ILLUSTRATIONS

Fig. No.	Page	Fig. No.	Page
1	4	24	17
2	5	25	17
3	6	26	17
4	6	27	18
5	7	28	20
6	7	29	20
7	8	30	20
8	10	31	21
9	11	32	23
10	11	33	24
11	11	34	25
12	11	35	26
13	12	36	27
14	12	37	28
15	13	38	29
16	13	39	30
17	14	40	30
18	14	41	30
19	14	42	31
20	14	43	32
21	15	44	33
22	16	45	35
23	17	46	35
		47	36
		48	37
		49	37
		50	38

ROYAL ENFIELD WORKSHOP MANUAL

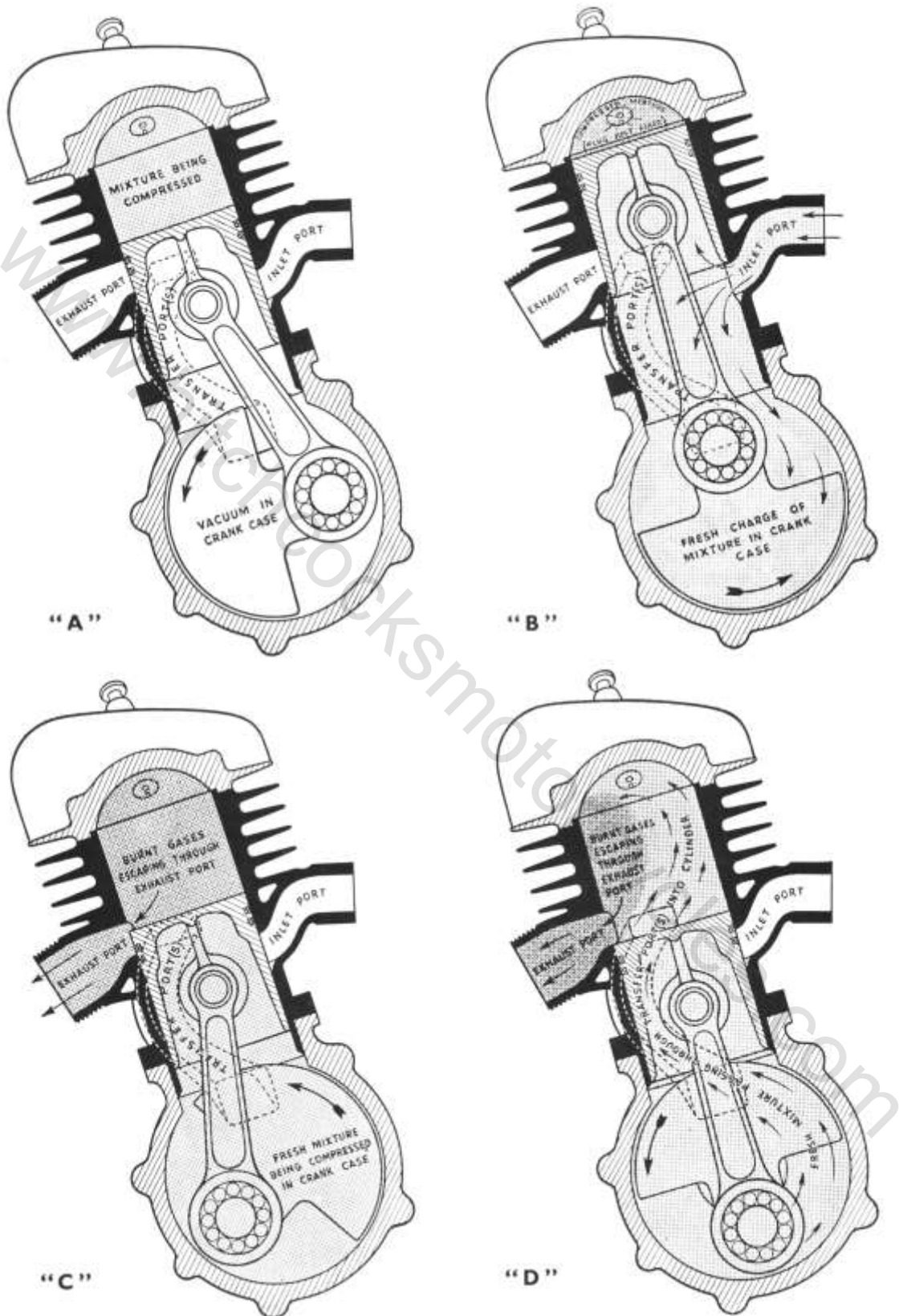

OPERATION OF THE TWO-STROKE ENGINE.

Fig. 1

ROYAL ENFIELD WORKSHOP MANUAL

ENGINE

OPERATION.

1. Principle of Operation of the Two-Stroke Engine.

The two-stroke cycle of operation is so called because it provides a firing stroke on one out of every two strokes of the piston, instead of one out of every four as with a four-stroke engine. Thus with a two-stroke engine every downward stroke of the piston is a firing stroke. The engine contains no valves, valve springs, cams or tappets, the passage of the gases in and out of the cylinder being controlled by ports in the cylinder wall which are covered and uncovered by movement of the piston. The principle of operation will be clearly understood on reference to Fig. 1. There are four ports in the cylinder, i.e., one exhaust one inlet and two transfer ports connecting the crankcase with the upper portion of the cylinder. (Only one transfer port is shown in the illustrations).

Diagram A shows the engine with the piston on the upstroke. All ports are closed and a fresh charge of gas which has been induced into the upper portion of the cylinder is being compressed ready for firing. At the same time, the upward movement of the piston creates a partial vacuum in the crankcase which is gas tight.

Diagram B shows the engine with the piston at the top of the stroke. The compressed mixture in the combustion chamber has just been fired by the sparking plug, thus providing the power to drive the piston down on the firing stroke. The inlet port has been uncovered by the lower edge of the piston and consequently air rushes into the crankcase to fill the vacuum which has been caused by the upward movement of the piston. This air is taken through the carburettor from which it picks up petrol and oil in vapour form.

Diagram C shows the piston near the bottom of the firing stroke. The fresh charge of mixture in the crankcase has been partly compressed by the downward movement of the piston and in the position shown the exhaust port is beginning to open so that the burnt gases in the cylinder rush out through the exhaust port and silencer, reducing the pressure in the cylinder very nearly to atmospheric pressure.

Diagram D shows the engine with the piston at the bottom of the stroke. The exhaust port is now fully open and the transfer ports are also open so that the fresh charge of compressed mixture in the crankcase is forced by its own pressure through the transfer ports into the cylinder ready to be compressed on the next upward stroke of the piston. There are two transfer ports (only one of which is shown in the diagram) and these are arranged in such a position that the two streams of incoming mixture are directed away from the exhaust port, meeting one another at the back of the cylinder and then sweeping upwards under the cylinder head, helping to push out the last remains of the burnt gases through the exhaust port.

It will be seen from the above explanation that :

- (i) As compared with a four-stroke engine running at the same speed there are twice the number of firing strokes per minute. On the other hand, the duration of the opening period of the inlet, transfer and exhaust ports is short, so that at high speeds it is difficult to induce a full charge into the cylinder. As a result of these two facts, the two stroke engine

gives very good power at low speeds but does not usually give such good power as a four-stroke engine at very high speeds. The two-stroke system is, therefore, particularly suitable for engines of small capacity which, if made on the four-stroke principle, require to be run at excessively high speeds in order to produce good power.

- (ii) The crankcase must be gas tight, thus necessitating a good joint between the two halves of the case and between the case and the cylinder base and also the use of some form of sealing arrangement behind the mainshaft bearings.
- (iii) The incoming gases are drawn first into the crankcase. It is this fact which makes it possible to lubricate a two-stroke engine by mixing oil with the petrol. On the other hand, the opening of the transfer port at the bottom of each stroke of the piston renders it impossible to flood the crankcase with a copious supply of oil as is done on most modern four-stroke engines, since this oil would reach the cylinder and sparking plug in excessive quantities. The petroil system of lubrication is adopted on this engine, the correct mixture being one part of oil to twenty-four parts of petrol. One great advantage of the petroil system is that the amount of oil drawn into the engine is automatically increased when running at high speed or large throttle openings.
- (iv) The piston rings must be pegged to prevent them from turning and catching in the ports.

DECARBONISING.

2. Removal of Cylinder and Cylinder Head.

Decarbonising will be necessary at rather more frequent intervals than is the case with engines of larger capacity and to obtain the best results it is desirable to carry out this operation every 2,000 to 4,000 miles. On the other hand, the amount of work involved is much less than with a four-stroke engine.

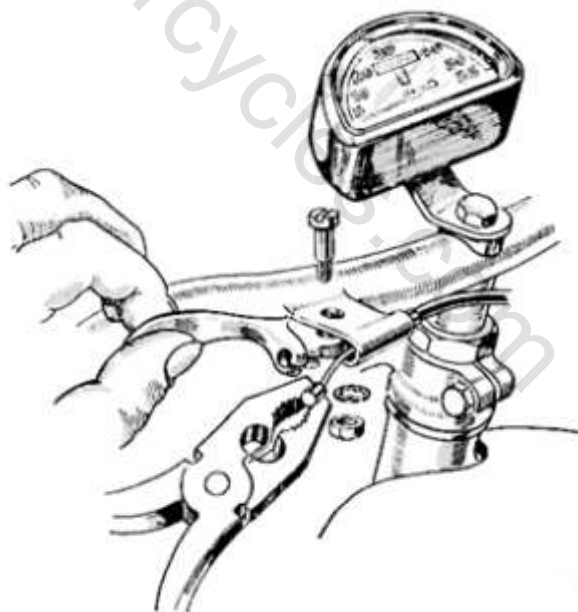

REMOVING DECOMPRESSOR LEVER.

Fig. 2

ROYAL ENFIELD WORKSHOP MANUAL

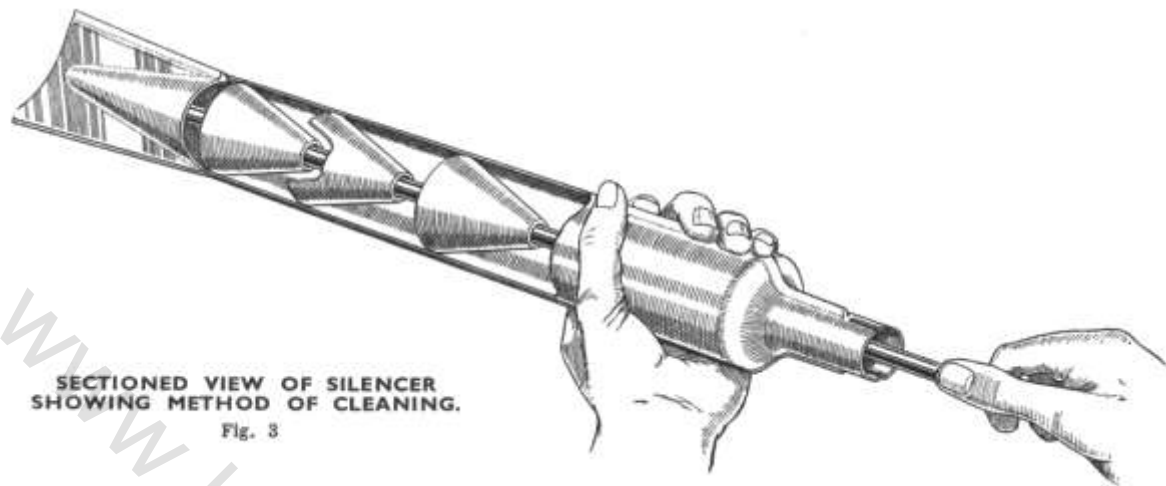

Before disturbing the cylinder, remove the exhaust pipe and silencer. Then disconnect the petrol pipe at the upper end, loosen the screw in the clip securing the carburettor to the cylinder, unscrewing the knurled ring at the top of the carburettor body, and remove the carburettor complete with air strangler and cleaner, leaving the throttle slide attached to the control wire. Next remove the screw and nut securing the decompressor control lever to the handlebar (see Fig. 2), disconnect the control wire from the lever, remove the lever and pull the wire and ferrule out of the clip welded to the handlebar. The decompressor can now be unscrewed from the cylinder head (or it can be left in place with the control wire and case coiled up out of the way). On no account try to unscrew the decompressor without having first disconnected the control wire from the handlebar lever.*

Now remove the H.T. cable and the sparking plug, unscrew the four nuts securing the cylinder base to the crankcase, place the piston at the bottom of its stroke and lift the cylinder and head off the piston.

The cylinder head can be removed from the barrel either before or after removal of the cylinder from the engine. To do this unscrew the four nuts securing the head to the barrel and lift the head away. The joint will probably have stuck and, to break it, it may be necessary to hit the inside of the head with a hammer shaft (after removal of the cylinder from the engine) or alternatively to prise the joint apart with two screwdrivers inserted between the head and the top cylinder fin. If this method is adopted, however, great care must be taken not to damage the fins. Removal of the cylinder head is not absolutely necessary but doing so does facilitate removal of carbon without risk of damage to the inside of the head.

3. Removal of Piston.

To remove the piston, push out the gudgeon pin after removal of one of the wire retaining circlips with a suitable tool (such as the tang end of a small file) and lift the piston off the connecting rod. If the gudgeon pin is tight in the piston bosses, tap it out gently with a hammer and drift,

* An alternative method is to remove the cylinder, or cylinder head, with the decompressor and its control in situ and then unscrew the cylinder from the decompressor, holding the latter stationary and turning the cylinder.

taking great care to support the piston firmly so as not to bend the connecting rod.

4. Removal of Carbon.

Carefully scrape the carbon deposit from the top and inside of the piston and the inside of the cylinder head. Remove the piston rings, noting which comes from which groove and carefully clean the grooves. Carbon deposit on the sides of the piston is best left alone except above the top ring where it should be removed.

Remove all carbon from the exhaust and transfer ports in the cylinder and also from the silencer baffles. There are three conical baffles in the silencer (see Fig. 3). The holes in these are on the centre line of the silencer and can be cleaned by carefully threading the silencer over a long steel rod about 3/8 in. diameter, held in a vice, and working the silencer about so that the carbon is removed from the baffles.

If preferred, the carbon can be removed from the cylinder and the silencer (and also from the exhaust pipe and expansion chamber) by immersing these parts in a solution of 4 ozs. commercial potash to a gallon of water. **On no account allow the potash solution to come into contact with the aluminium piston and cylinder head.**

5. Piston and Rings.

If the piston rings are in good condition they can be replaced, taking care to fit them in the original grooves and the right way up, as indicated by the slots for clearance of the piston ring stops situated in the ring grooves (see Fig. 4). If the rings show brown or black patches on their working faces or if their gaps when in position in the barrel are more than 1/16 in., new rings should be fitted. The correct gap for new rings is .008 in.-.012 in. The gap should be measured in the least worn part of the cylinder which will be found to be at the extreme top or bottom of the bore.

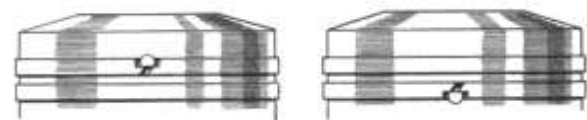

PISTON RING GAPS AND STOPS.

Fig. 4

ROYAL ENFIELD WORKSHOP MANUAL

The original size of the cylinder bore is 2.126 ins. If the wear at any point exceeds .008 in.-.010 in. the cylinder should be rebored and an oversize piston fitted. Pistons are available .015 in. and .030 in. oversize. The original diameter of the piston skirt measured fore and aft is 2.1215 ins. at the bottom and 2.119 ins. at the top. Diameters parallel to the gudgeon pin are .004 in. less. The original side clearance between the piston rings and grooves is .003 in. If the piston skirt or ring grooves show .005 in. wear, the piston should be replaced, after checking the cylinder for wear and reboring if necessary.

6. Big-End Bearing.

While the piston is removed, examine the condition of the big-end bearing. This consists of a single row of rollers $\frac{1}{4}$ in. diameter $\frac{1}{2}$ in. wide. Owing to the narrowness of the bearing, the slightest trace of wear will result in a considerable amount of side shake in the connecting rod. If, however, definite up and down play can be felt, the engine should be stripped further to have the big-end and crank-pin examined for wear.

7. Small-End Bearing.

The gudgeon pin should be a push fit in the piston (when cold) and a free working fit (.001 in. clearance) in the small-end bush. The small-end bush can be renewed, if worn, without removing the engine from the frame, using a draw bolt as shown in Fig. 5, both for withdrawing the old bush and fitting the new one.

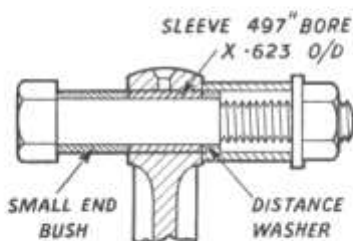
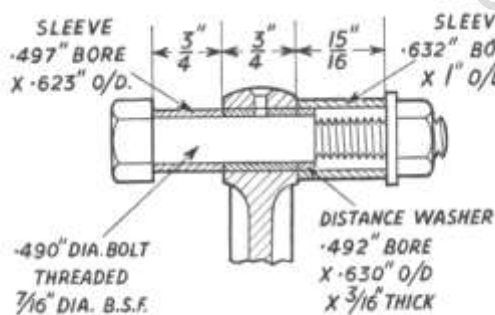

REMOVING AND REPLACING SMALL END BUSH.

Fig. 5

After fitting, the bush must be reamed (the size to suit a new gudgeon pin being .497 in.) and the oil hole drilled in the bush, using the hole in the connecting rod as a guide.

8. Decompressor. (See Fig. 6).

If the decompressor valve holds compression and operates freely there is no need to interfere with it except to remove carbon from the head of the valve.

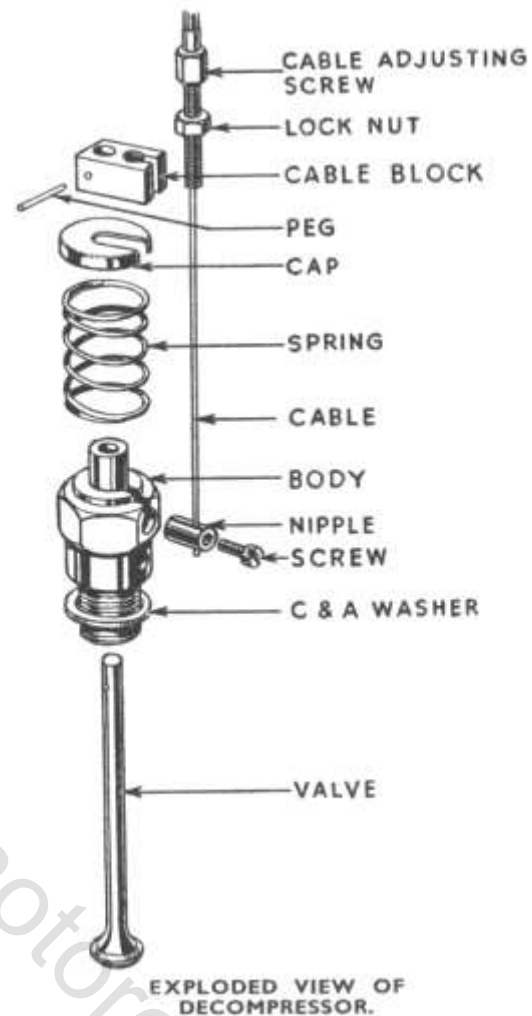

EXPLODED VIEW OF DECOMPRESSOR.

Fig. 6

If the valve is leaking, it will be necessary to regrind it on to its seat. This can be done without dismantling the decompressor completely, the procedure being as follows:- Having disconnected the control wire from the handlebar lever (see Para. 2) and unscrewed the decompressor from the cylinder head, compress the spring with the fingers and remove the spring cap. Now screw the adjusting screw (with locknut) out of the block on top of the decompressor valve and pull the cable sideways out of the slot in the block. Push the spring upwards with the fingers and pull the cable nipple out of the decompressor body. Note that this nipple is not of the solderless type, the screw in it being merely an added security in case the heat of the engine softens the solder which secures the nipple to the cable. It will now be found possible to thread the wire and nipple through the spring leaving the decompressor body, with the valve, block and spring, detached from the control cable. The spring cap should now be replaced after which the valve and valve seat should be examined for pitting or other cause of leaks. The valve may now be ground in by applying a thin coating of grinding paste on the valve seat and twisting to and fro by means of the block fixed to its upper end, occasionally lifting the valve from its seat. Do

ROYAL ENFIELD WORKSHOP MANUAL

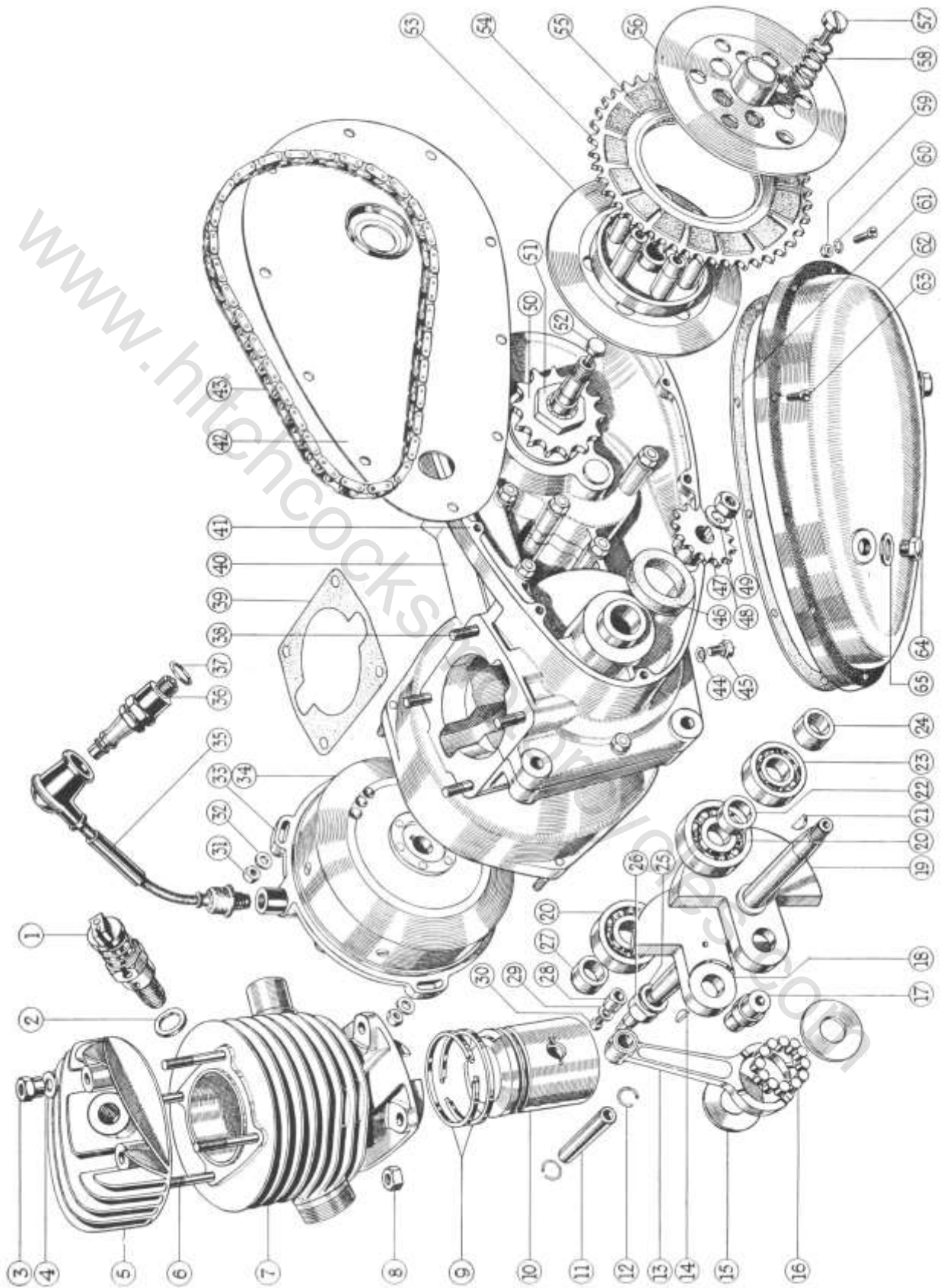

ROYAL ENFIELD WORKSHOP MANUAL

- | | | | |
|------|--------------------------------------|------|---|
| (1) | Decompressor complete. | (34) | Magneto Flywheel. |
| (2) | Decompressor Joint Washer. | (35) | Magneto H.T. Cable Complete. |
| (3) | Cylinder Head Nut. | (36) | Sparkling Plug. |
| (4) | Cylinder Head Washer. | (37) | Sparkling Plug Washer. |
| (5) | Cylinder Head. | (38) | Cylinder Base Stud. |
| (6) | Cylinder Head Stud. | (39) | Cylinder Base Joint Washer. |
| (7) | Cylinder Barrel. | (40) | Crankcase, Flywheel Side. |
| (8) | Cylinder Base Nut. | (41) | Crankcase, Driving Side. |
| (9) | Piston Ring. | (42) | Front Chain Cover Backplate. |
| (10) | Piston. | (43) | Primary Chain. |
| (11) | Gudgeon Pin. | (44) | Crankcase Drain Plug Fibre Washer. |
| (12) | Gudgeon Pin Retaining Circlip. | (45) | Crankcase Drain Plug. |
| (13) | Connecting Rod with Small End Bush. | (46) | Front Chain Cover Felt Washer. |
| (14) | Magneto Flywheel Key. | (47) | Engine Sprocket. |
| (15) | Crankpin Thrust Washer. | (48) | Engine Sprocket Washer. |
| (16) | Crankpin Roller. | (49) | Engine Sprocket Nut. |
| (17) | Crank Pin. | (50) | Gearbox Sprocket. |
| (18) | Crankshaft, Flywheel Side. | (51) | Gearbox Sprocket Nut. |
| (19) | Crankshaft, Driving Side. | (52) | Clutch Operating Rod Pad. |
| (20) | Crankcase Ball Bearing, S.K.F.6302. | (53) | Clutch Centre Assembly. |
| (21) | Engine Sprocket Key. | (54) | Clutch Sprocket Assembly. |
| (22) | Distance Collar, Engine Drive Shaft. | (55) | Clutch Sprocket Cork Insert. |
| (23) | Crankcase Ball Bearing, S.K.F.6203. | (56) | Clutch Front Plate. |
| (24) | Sealing Bush, Engine Drive Shaft. | (57) | Clutch Spring Retaining Screw. |
| (25) | Flywheel Magneto Washer. | (58) | Clutch Spring. |
| (26) | Flywheel Magneto Nut. | (59) | Front Chain Cover ¼ in. dia. Nut. |
| (27) | Sealing Bush, Engine Flywheel Shaft. | (60) | Front Chain Cover Shakeproof Washer. |
| (28) | Magneto Cam. | (61) | Front Chain Cover Joint Washer. |
| (29) | Magneto Cam Washer. | (62) | Front Chain Cover. |
| (30) | Magneto Cam Screw. | (63) | Front Chain Cover ¼ in. dia. Screw. |
| (31) | Magneto Coil Plate Nut. | (64) | Chain Case Oil Filler (or Drain) Plug. |
| (32) | Magneto Coil Plate Washer. | (65) | Chain Case Oil Filler (or Drain) Plug Fibre Washer. |
| (33) | Magneto Coil Plate Assembly. | | |

EXPLODED VIEW OF ENGINE.

Fig. 7

ROYAL ENFIELD WORKSHOP MANUAL

not rotate the valve through a complete revolution before lifting as this would groove the seat. After the seat has been ground in, wash the whole assembly thoroughly in clean petrol, opening and shutting the valve with the fingers while doing so. Make sure that all traces of grinding paste have been removed. If paste should get into the cylinder, serious damage will be caused.

If the valve shows a tendency to stick open in the body but is otherwise satisfactory, this can probably be cured by washing in petrol as described above, though in this case it is not really necessary to disconnect the control cable.

If the valve is badly burnt or bent, or if the stem is heavily coated with carbon so that it sticks open, it will be necessary to dismantle the decompressor completely. To do this remove the decompressor from the cylinder head, as described above and knock out the small Mills peg which fastens the cable block to the valve stem. The cable block can now be drawn off, after which the whole assembly will come apart. This procedure is also necessary if it is required to renew the decompressor spring.

9. Reassembly of Engine after Decarbonising.

When reassembling the engine take great care to have all parts perfectly clean and put clean oil on the piston, particularly round the rings. The cylinder base joint must be made with a paper washer. If the old washer is damaged, a new one must be fitted, taking particular care to remove all traces of the old washer. A *gas tight* joint is necessary at this point with a two stroke engine. When fitting the cylinder take care that the piston ring gaps are in the correct position in relation to the piston ring stops (see Fig. 4).

Note that the piston must be assembled with the piston ring gaps and stops slightly to the rear of the gudgeon pin.

If the cylinder head has been removed, make sure that the surfaces on both the head and the cylinder are clean and

free from burrs or other marks that may cause the joint to leak. Remake the joint with gold size, shellac or a similar compound. If any trouble is experienced in making a satisfactory joint, remove the four studs from the cylinder barrel and lap the joint faces together with fine valve paste, *taking care to remove all traces of the lapping compound before replacing the cylinder head.* Do not omit the washers beneath the cylinder head nuts. Tighten both the cylinder base nuts and the head nuts "diagonally" and check for tightness with the engine warm.

When refitting the decompressor control lever to the handlebar, note that the head of the bolt is fitted above the clip welded to the handlebar. Adjust the decompressor control by means of the adjusting screw at the lower end (see Fig. 6), so that there is a little slack in the cable. Check this with the bars central and also turned to full lock on either side.

COMPLETE OVERHAUL.

10. Removal of Engine and Gear Box Unit from Frame.

To remove the engine and gear unit from the frame, first remove the carburettor, then disconnect the exhaust pipe and the decompressor control from the handlebar lever (see Para. 2). Remove the rear chain- disconnect the rear chain by means of the spring link fastener and remove the chain. Disconnect the gear control rod by removing the split pin (or bolt and nut on later models) at the lower end. Disconnect the clutch control cable from the lever on the gearbox. Unscrew the nuts on the four bolts which secure the engine and gear unit into the frame and withdraw the bolts. The engine and gear unit can now be lifted out of the frame.

11. Dismantling the Crankcase. (See Fig. 7.)

Owing to the unit construction of the engine and gearbox it is not possible to dismantle the crankcase without disturbing the gearbox, gears and shafts. The following description, however, assumes that the gearbox is in good order and that the unit is being dismantled to replace some component of the engine. For details of dismantling the gearbox parts see Para. 20. It will be found a great convenience to hold the engine in a fixture such as is shown in Fig. 8.

First remove the front chain cover by unscrewing the ten screws which attach it to the crankcase. These all screw into the aluminium crankcase with the exception of the one immediately in front of the chainstay, which has a nut behind it. Remove the chain cover after placing a tray beneath the engine to catch any oil which may run out. Now unscrew the six clutch spring retaining screws and lift away the front plate of the clutch, followed by the clutch sprocket assembly and the primary chain. Unscrew the engine sprocket nut and withdraw the sprocket from its taper, using an extractor similar to that shown in Fig. 9. Remove the engine sprocket key.

Unscrew the nut which attaches the clutch centre to the gearbox mainshaft. The shaft can be prevented from rotating by placing the gears in the top gear position (gear lever on box right down) and holding the gearbox sprocket by means of a length of rear chain attached to a piece of steel rod about 6 in. long. Withdraw the clutch centre assembly from the gearbox mainshaft using an extractor similar to that shown in fig. 10. Remove the mainshaft key

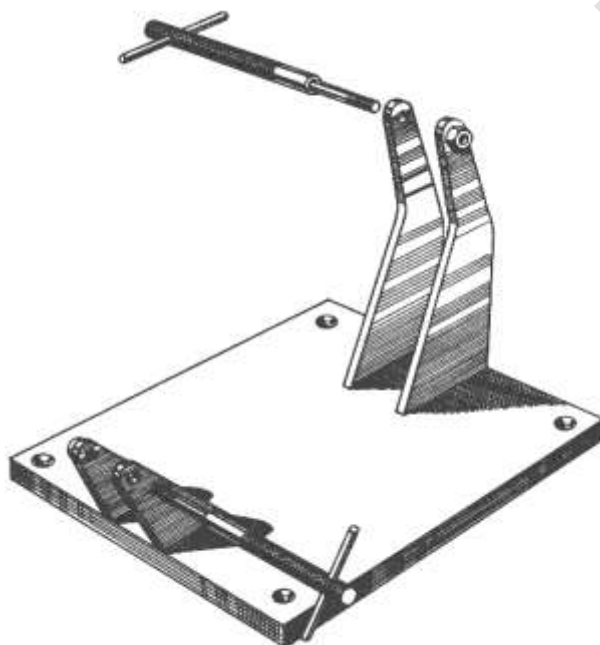

FIXTURE FOR HOLDING ENGINE.

Fig. 8

ROYAL ENFIELD WORKSHOP MANUAL

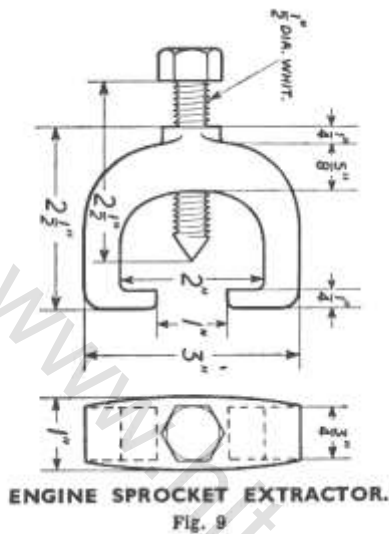

and keep it separated from the engine sprocket key, then remove the clutch operating rod pad and the front chain cover back plate.

Remove the magneto contact breaker cover. Unscrew the bolt which secures the contact breaker cam. Remove the cam which is threaded internally 5/16 in. B.S.F. and can be withdrawn by screwing a bolt of this size into it so as to bear against the end of the crankshaft. Unscrew the three nuts securing the magneto coil plate. Disconnect the H.T. cable from the sparking plug and pull the lighting cable plug out of its socket. Withdraw the magneto coil plate, tapping one of its attachment lugs gently with a soft mallet to separate the joint between it and the crankcase. When removing the magneto coil plate exert an even hand pull at top and bottom thereby avoiding the possibility of the bearing (located inside the cover) tilting and binding on the shaft.

Unscrew the nut which secures the magneto flywheel to the crankshaft. This has a right-hand thread and the spanner may require one or two blows with a hammer to slacken the nut. Now withdraw the flywheel, using an extractor as shown in Fig. 11. To operate this extractor the sleeve portion C is screwed on to the thread B and the

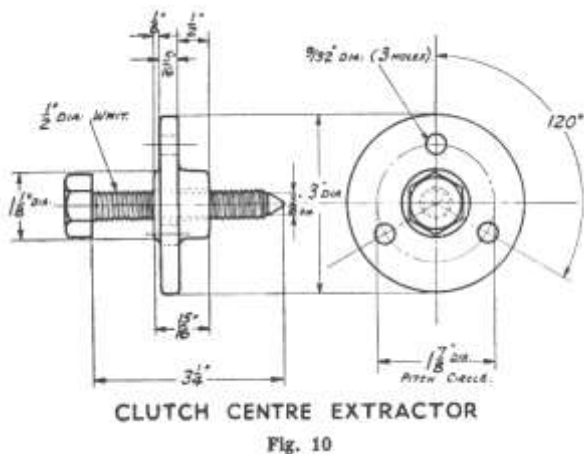

collar D is screwed on to the thread A. The socket key E is inserted into the hexagon socket in the protruding end of C, which is then unscrewed while the collar D is prevented from turning by means of a spanner applied to the hexagon formed on it. The flywheel is thus drawn off its taper without any strain being placed on the end of the crankshaft.

Take out the sparking plug. Remove the cylinder, see Para. 2. Remove one gudgeon pin circlip, push out the gudgeon pin and remove the piston, see Para. 3. Remove the paper cylinder joint washer.

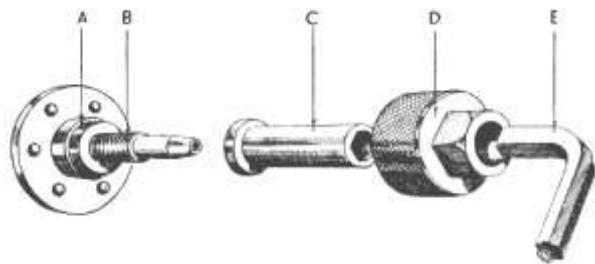

Remove the kickstarter crank complete after loosening the pinch bolt which secures it to the serrations on the kickstarter axle. Unscrew the nine nuts (eight on left, one on right-hand side) which hold the two halves of the case together, turn the case over on the magneto side, preferably on to a fixture such as is shown in Fig. 12, tap the underside of one of the cylinder studs in the upper half of

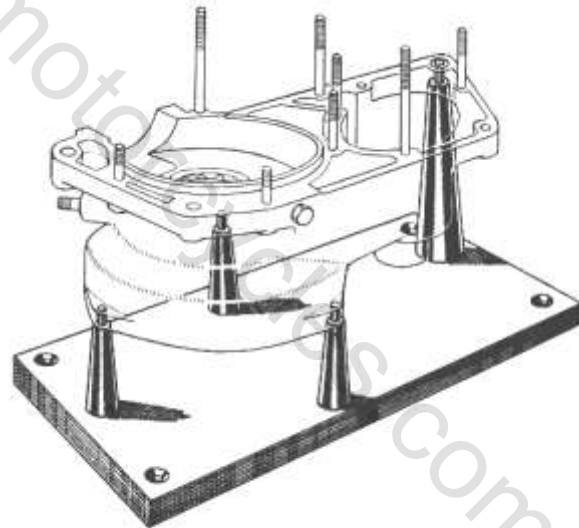

the case gently to break the crankcase joint and lift the upper half of the case away, leaving the gearbox shafts, gear wheels and crankshaft in the lower half. The crankshaft can now be lifted out. If work has to be done on the magneto side of the case the gear and shafts can be lifted out after disengaging the pegs, on the inside gear operator, from the grooves in the two sliding pinions (see Fig. 27).

ROYAL ENFIELD WORKSHOP MANUAL

12. Dismantling the Crankshaft.

The crank webs are a press fit on the crankpin and a special fixture is desirable to hold the crankshaft when pressing the pin out of the first crank web as it is impossible to support the crank web immediately beneath the point of application of pressure. A suitable fixture is shown in Fig. 13.

13. Connecting Rod.

The original bore of the big-end of the connecting rod is 1.2236 ins. and of the small-end bush .497 in. If the roller track in the big-end of the connecting rod is worn it is necessary to replace the complete rod. If the small-end bush is worn this can be pressed out and a new one fitted (see Para. 7). If a new small-end bush has been fitted or if, at any time, the piston shows signs of having been tilted in the barrel, the connecting rod should be checked for bend or twist, using the fixtures shown in Figs. 14 and 15. It is one of the features of a two-stroke engine that the load on the connecting rod is less than for a four-stroke engine of equal power and consequently a light section rod can be used with safety. This, however, is easily damaged by careless handling and consequently must be treated with care once it has been carefully set. Any bend or twist made apparent by this test should be corrected by gripping the big-end of the connecting rod in a vice with smooth jaws and setting the rod by means of a long, well-fitting rod through the small-end bush.

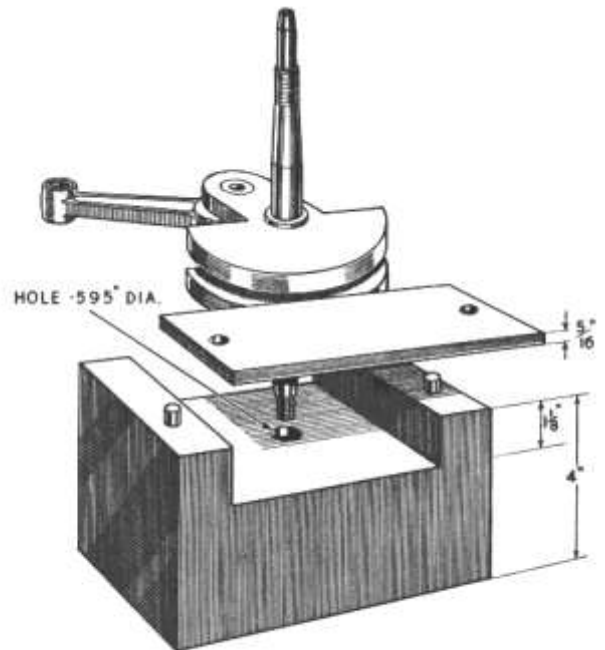

FIXTURE FOR SEPARATING CRANKSHAFTS.

Fig. 13

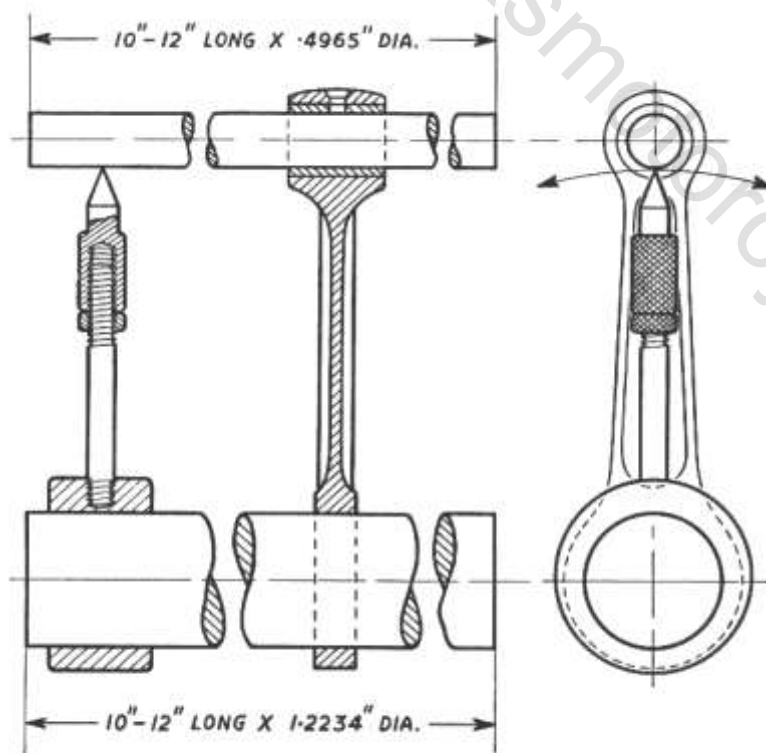

TEST BARS AND GAUGE FOR CHECKING CONNECTING ROD FOR "BEND."

Fig. 14

14. Big-End Bearing.

The original diameter of the centre portion of the crankpin is .7236 in. Rollers are available in sizes differing by .0001 in. ranging from .2492 in. to .2500 in. A suitable size of roller must be used to obtain a bearing which runs freely with the minimum of clearance. The maximum permissible clearance for a new bearing is .0003 in. .0005 in. When assembling the big-end bearing, wrap a piece of fine string round the rollers to hold them in position round the crankpin to enable the connecting rod to be fitted over the rollers.

15. Reassembly of Crankshaft.

Special fixtures are necessary to reassemble the crankshaft if this is to run dead true without subsequent setting. It is, however, quite easy to assemble and true the shaft without any special apparatus. To do this, drive the crankpin into one crank web with one of the hardened thrust washers between the crank web and the centre portion of the pin, then grip the engine shaft vertically between lead jaws in a vice with the inner face of the crank web horizontal. Assemble the big-end bearing and connecting rod, pouring a little clean oil between the rollers. Place the second hardened thrust washer and second crank web over the exposed end of the crankpin. Tap the second crank web about half way on to the exposed end of the crankpin with a

ROYAL ENFIELD WORKSHOP MANUAL

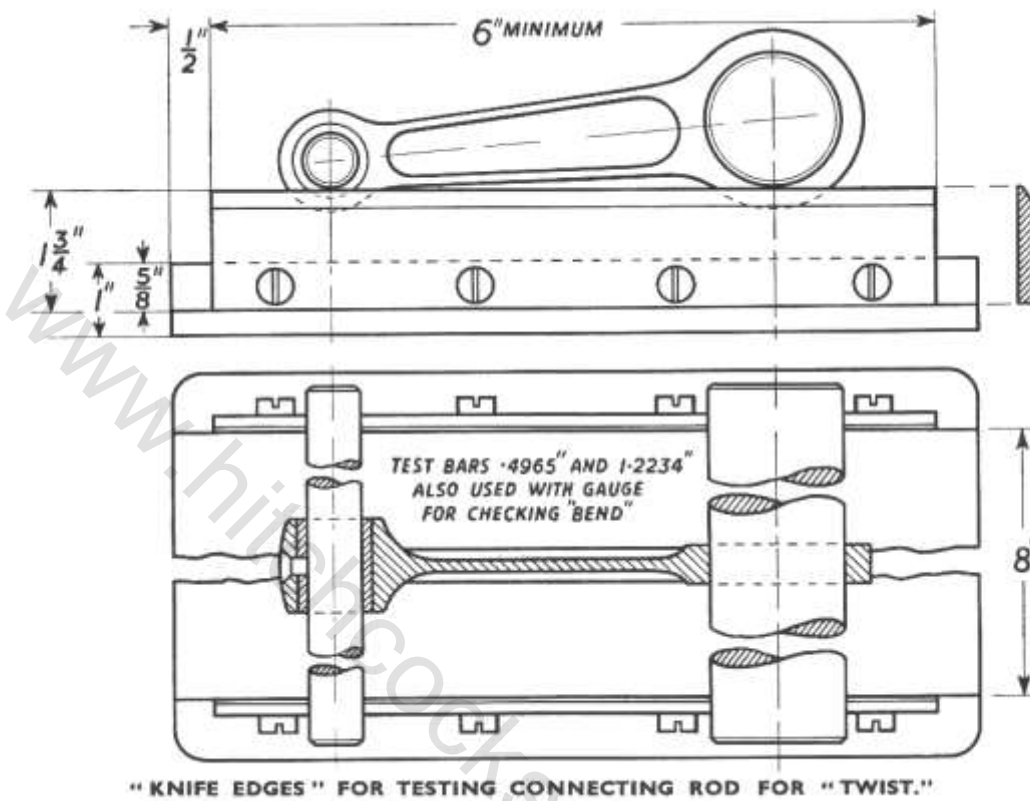

Fig. 15

hammer and drift applied over the crank throw hole. Remove the partially assembled crankshaft from the vice and check it roughly for truth by placing a straight edge across the edges of the balance weights as nearly as possible 90° from the crankpin. Tap the partly assembled crank web round the pin if necessary to line up the balance weights. Grip the crank webs between the jaws of the vice with a short tubular distance piece between the jaws and the webs (see Fig. 16), and screw up the vice to drive the pin home into the crank web.

The crankshaft must now be carefully trued by placing the whole assembly between centres and checking the truth of the shafts with a dial micrometer (clock gauge). The shafts must run true to within .001 in. When finally trued up, make sure that the connecting rod has .008 in. - .015 in. side clearance.

16. Removing and Refitting Crankcase Bearings and Sealing Bushes.

The crankcase main bearings and the bronze sealing bushes can be removed by driving or pressing them into the case using a drift $3/4$ in. diameter with the end reduced to $37/64$ in. diameter to form a pilot to locate the drift in the sealing bush.

The sealing bushes will not wear unless the engine has been running with badly worn ball bearings. If this is the case, or if the sealing bushes have seized on the shaft, they must be replaced. The new bushes should be fitted before replacement of the ball bearings and must be reamed after fitting to .594 in. bore, using a reamer with a pilot $7/16$ in.

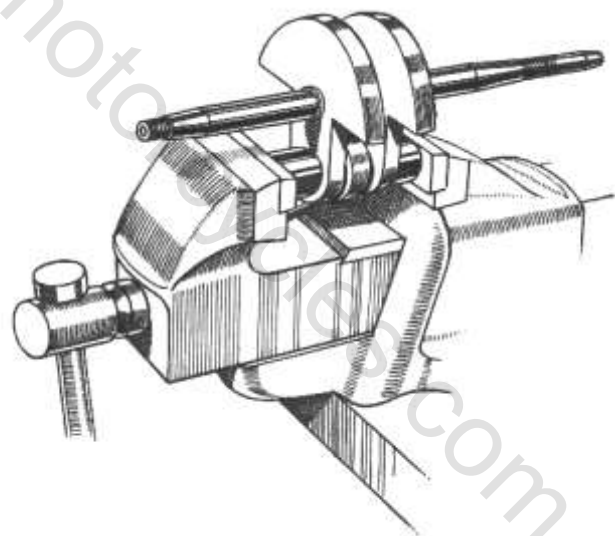

ASSEMBLING CRANKSHAFTS IN VICE.

Fig. 16

diameter and 1.1/2 in. long, guided in a hardened steel bush which replaces the ball bearing. Details of these bushes for both sides of the case are shown in Figs. 17 and 18.

After reaming the sealing bushes, the hardened steel bushes are pressed out of the case and the ball bearings are

ROYAL ENFIELD WORKSHOP MANUAL

pressed in, using drifts, as shown in Figs. 19 and 20 to ensure that the bearings are in line with the sealing bushes and that the two bearings on the driving side are in line with each other.

17. Reassembling the Crankcase.

If the studs which hold the crankcase together have been removed, these must be replaced in the correct positions as there are several different lengths of stud. Fig. 21 indicates the length of stud to fit in each hole. All the studs are fitted with the longer threaded portion screwed into the aluminium with the exception of the three studs which attach the magneto coil plate to the crankcase, which should be fitted with the shorter threaded portion in the aluminium.

The joint between the two halves of the crankcase and that between the two halves of the gearbox must be made with gold size, shellac or a similar jointing compound.

Assemble the crankshaft and gearbox shafts and gears (see Para. 23) into the driving side of the case and then fit the magneto side of the case into place, securing it with the nine nuts (eight on the driving side, one on the magneto side) with a plain washer beneath each. Note that the studs in positions numbers 7 and 10 (see Fig. 21) are fitted with nuts having extra small hexagons. The remainder of the nuts have standard size hexagons. Replace the piston and cylinder (see Para. 9).

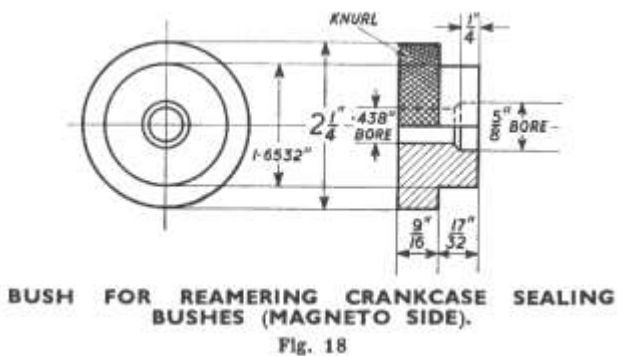
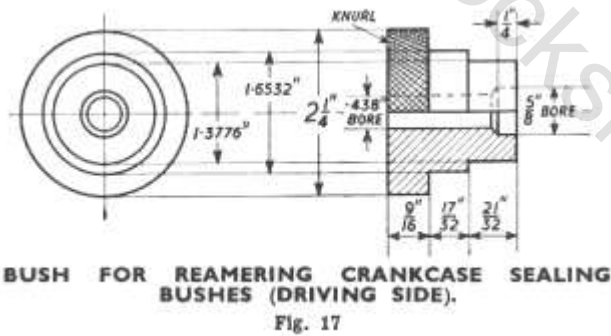

Replace the front chain cover backplate, gearbox mainshaft key, engine sprocket key, the clutch operating rod pad and the clutch centre assembly, tightening the nut which secures the latter by engaging top gear and holding the countershaft sprocket with a length of chain in a similar manner to that employed when dismantling the crankcase. Now replace the clutch sprocket assembly, together with the engine sprocket and primary chain. This chain should have

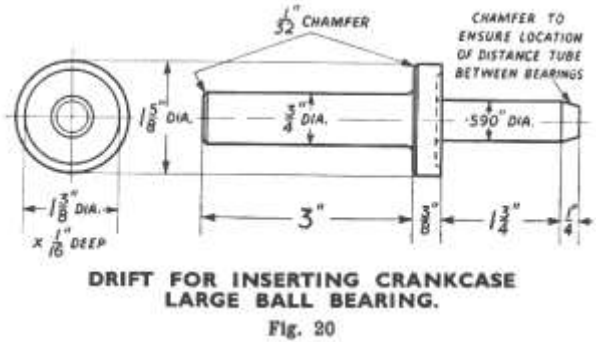
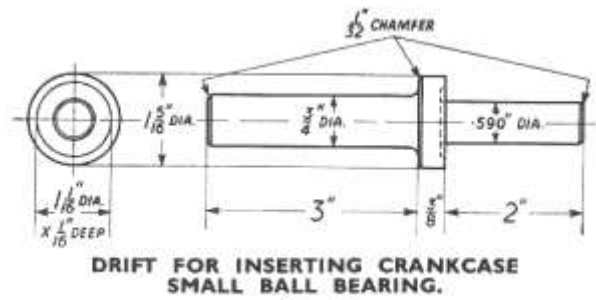

approximately 1/4 in. free up and down movement at a point midway between the two sprockets. There is no means of adjusting the chain, which should be replaced if it has worn to such an extent that the free up and down movement is more than 4 in. Replace the clutch pressure plate and the six springs and spring retaining screws. If washers have been fitted beneath the heads of these screws, additional spring pressure can be obtained by omitting the washers. On no account, however, must one retaining screw be fitted with a washer and the one diametrically opposite to it without one.

Replace the front chain cover joint washer and the front chain cover. In order to make sure that an oil tight joint is obtained at the rear portion of the cover where the backplate is unsupported by the aluminium casting, the joint washer at this point should be coated on both sides with shellac or gold size. It is also a good plan to bend the backplate slightly forwards at this point and the cover plate slightly backwards to increase the pressure between the faces.

Now refit the magneto flywheel key (note that this is wider than either the engine sprocket key or gearbox mainshaft key) replace the magneto flywheel and tighten up the nut securing it, **using a well-fitting tube or box spanner and a hammer to make sure that this is really tight.** Replace the magneto coil plate with the securing studs central in each of the three slots.* Fit the contact breaker cam into position on the tapered end of the crankshaft, turn the cam round until the points are fully open and see that these open to .015 in. Rotate the engine until the piston is at t.d.c., then turn it backwards until the piston has descended 5/32 in. to 3/16 in. Turn the cam forwards until the contact points are just about to open. Give the end of the cam a sharp tap to make it bind on the taper, then secure it with the 3/16 in. set pin which has a plain washer beneath the head. Check the timing after tightening the set pin.

* On the most recent models the slots have been replaced by drilled holes, thus automatically ensuring the correct position of the Stator plate.

ROYAL ENFIELD WORKSHOP MANUAL

Note. With this type of magneto the best spark is obtained only at this setting. If the timing is too early the spark will be very weak, while if it is too late excessive sparking will occur at the contact breaker points. A small range of advance or retard is obtainable by turning the cover plate on the slots.*

This alters the timing relative to the engine without affecting the quality of the spark.

Replace the kickstarter crank when the engine and gear unit will be ready for replacing in the frame.

18. Replacing Engine and Gear Unit in Frame.

To replace the engine and gear unit in the frame reverse the procedure detailed in Para. 10. Adjust the control cable so that there is approximately 1/16 in. movement at the end of the clutch operating lever on the gearbox. If necessary adjust the gear control gate by loosening the small set screw which secures it to the tank and pivoting the gate until it occupies such a position that the lever lies central in the second gear position when second gear is engaged.

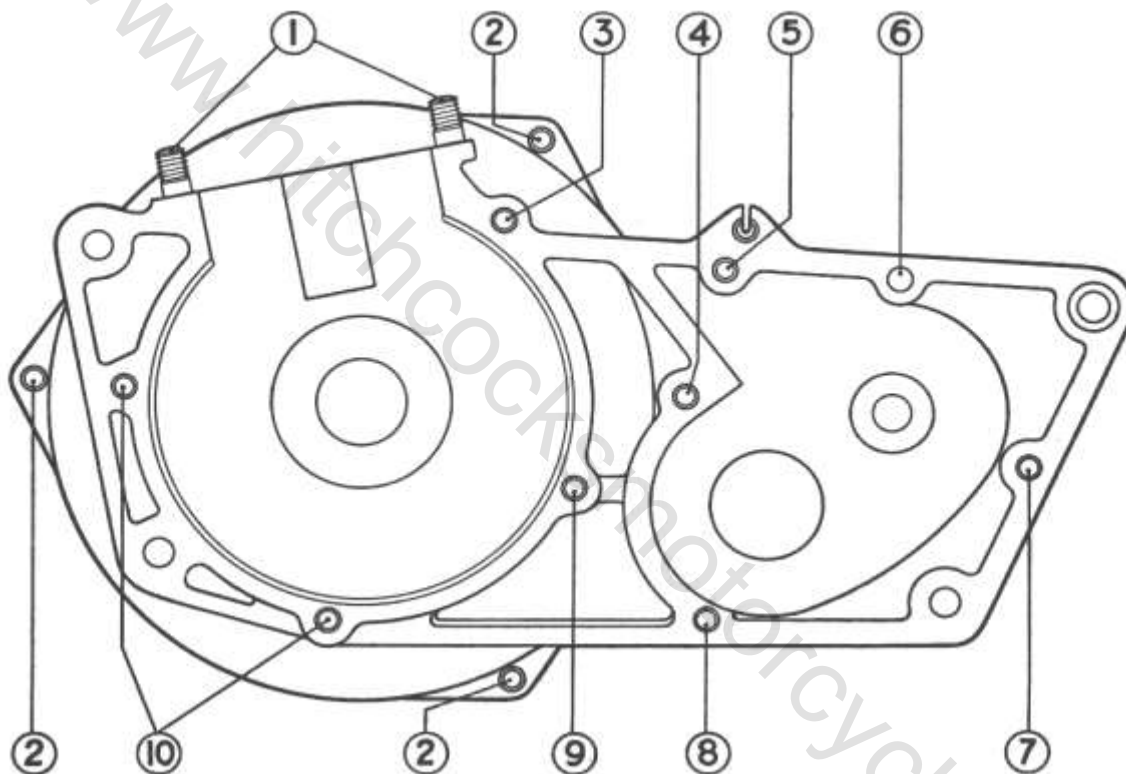

Ref. No.	Diameter	Length	Part No.	Notes
1	5/16"	1 1/8"	12240	4 off
2	1/4"	1 1/32"	24883	3 off
3	1/4"	2 3/4"	26494	1 off
4	1/4"	1 7/8"	10772	1 off
5	1/4"	2 1/4"	26491	1 off
6	1/4"	2 3/8"	26492	Screws into other half of case
7	1/4"	2"	27089	Small nut
8	1/4"	2 5/8"	26493	1 off
9	1/4"	1 5/8"	26490	1 off
10	1/4"	1 1/4"	26489	2 off. Small nuts

POSITIONS OF STUDS IN CRANKCASE

Fig. 21

ROYAL ENFIELD WORKSHOP MANUAL

TRANSMISSION

19. Operation of Gearbox.

The operation of the gearbox will be understood by reference to Fig. 22, which shows the gears in the top gear position.

The 15 T. mainshaft pinion is mounted on splines on the mainshaft and always rotates with the shaft.

The 21 T. mainshaft pinion slides on the mainshaft and when in the position shown, engages with the splined portion of the mainshaft.

The 26 T. final drive pinion is integral with the final drive sleeve which is free to turn on the mainshaft. The countershaft sprocket is attached by splines to the final drive sleeve.

The 27 T. layshaft pinion is free to turn on the layshaft.

The 21 T. layshaft pinion slides on the layshaft and in the position shown is clear of the splined portion of the shaft.

The 16 T. layshaft pinion is mounted on splines on the layshaft.

In the position shown (top gear being engaged) the drive is transmitted from the mainshaft through the splines to the 21 T. mainshaft pinion which engages the 26 T. pinion on the final drive sleeve by means of dog clutches so

that a direct drive is obtained from the mainshaft to the final drive sleeve. The layshaft is driven round by the 26 T. and 16 T. pinions with the 27 T. and 21 T. layshaft pinions running free on it.

To obtain second gear, the two sliding 21 T. pinions are moved to the left until the dogs on the 21 T. mainshaft pinion disengage from the 26 T. final drive pinion and the 21 T. layshaft pinion engages with the splined portion of the layshaft. The drive from the mainshaft to the final drive sleeve is now taken through the 21 T. pinions to the layshaft and then through the 16 T. and 26 T. pinions to the final drive sleeve with the 27 T. layshaft pinion still running free on its shaft.

To obtain neutral gear the two sliding pinions move further to the left until the 21 T. mainshaft pinion is disengaged from the splines on the mainshaft but not sufficiently far to engage the dogs on the end of the 21 T. layshaft pinion with those on the 27 T. layshaft pinion. Rotation of the mainshaft now causes rotation of the 15 T. and 27 T. pinions only, the latter running free on the layshaft.

To obtain bottom gear the two sliding bushes are moved further to the left until the dogs on the 21 T. layshaft pinion engage with those on the 27 T. pinion, thus

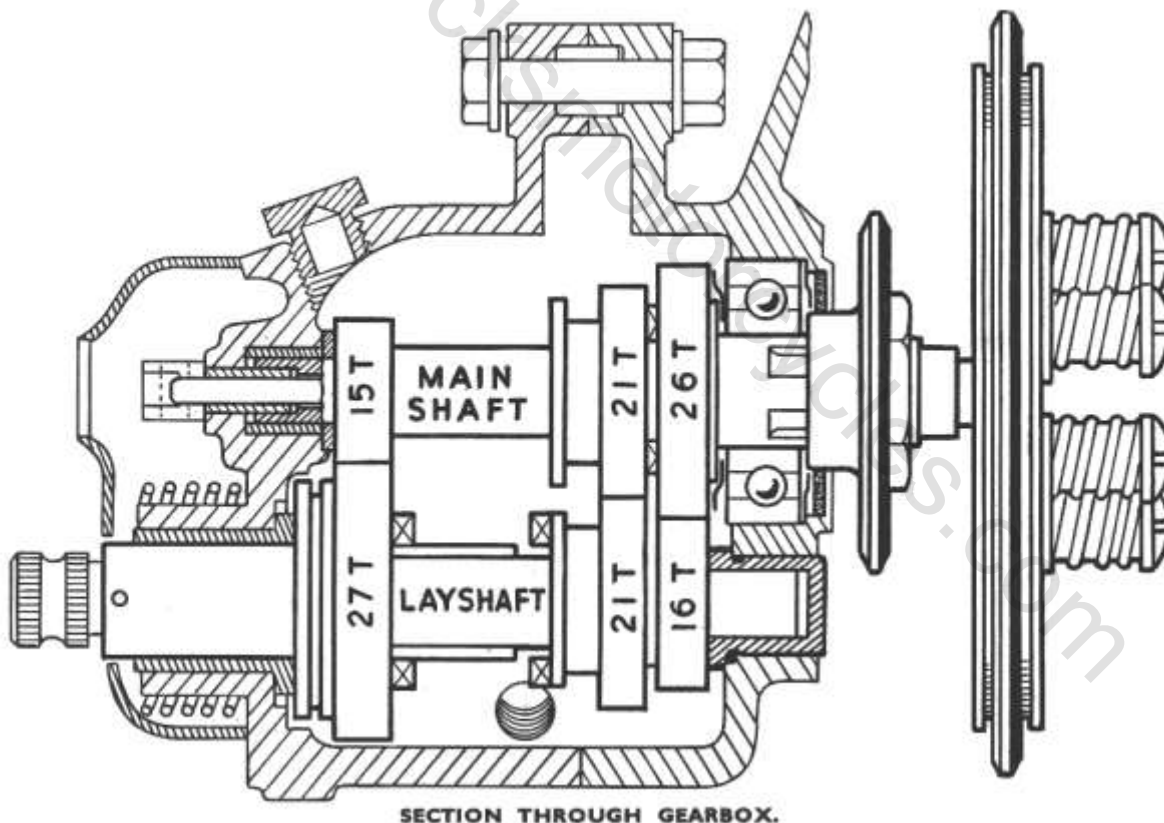

Fig. 22

ROYAL ENFIELD WORKSHOP MANUAL

clutching the latter to the layshaft. The drive is now taken from the mainshaft through the 15 T. and 27 T. pinions to the layshaft and then through the 16 T. and 26 T. pinions to the final drive sleeve. The 21 T. mainshaft pinion is driven round by the 21 T. layshaft pinion, but is free to turn on the mainshaft.

20. Dismantling the Gearbox.

Before the gearbox can be dismantled the entire engine and gear unit must be removed from the frame as described in Para. 10. The crankcase can then be dismantled as described in Para. 11 except that if no work is to be done on the crankshaft or the bearings in the magneto side of the case it is not necessary to disturb the contact breaker or flywheel magneto while, on the other hand, if access is required to the kickstarter spindle or to the bush in which it fits, the clutch operating lever cover posts must be removed, after which the clutch operating lever cover can be lifted away and the kickstarter crank return spring removed. The kickstarter spindle can then be withdrawn from its bush.

If it is required to renew the mainshaft ball bearing or felt oil seal behind it, the 26 T. final drive pinion and the final drive sprocket must be removed after unscrewing the nut which secures it. This should preferably be done before separating the two halves of the crankcase. When unscrewing the nut the final drive sleeve can be prevented from turning by holding the sprocket with a length of chain as suggested in Para. 11. The sprocket is fitted on splines on the final drive sleeve and can be removed with the aid of two screwdrivers or tyre levers placed behind it.

21. Removal of Gearbox Bearings.

The gearbox main ball bearing can be driven into the gearbox using a drift as shown in Fig. 23. The kickstarter spindle bush can also be driven into the gearbox using a drift as shown in Fig. 24. The layshaft bush at the driving

end of the gearbox can be driven in using a plain drift $\frac{43}{64}$ in. in diameter.

If the bush inside the kickstarter spindle require removing, probably the best way to do this is to fill it with soft grease and then drive into it a mandrel .498 in. diameter, which will cause the grease to force the bush out of the kickstarter spindle.

Probably the best way to remove the bush in which the mainshaft runs in the kickstarter side of the gearbox is to tap this with a thread $\frac{9}{16}$ in. diameter, and pull the bush out with the tackle shown in Fig. 25. If the bush is very tight its removal will be facilitated by warming the case.

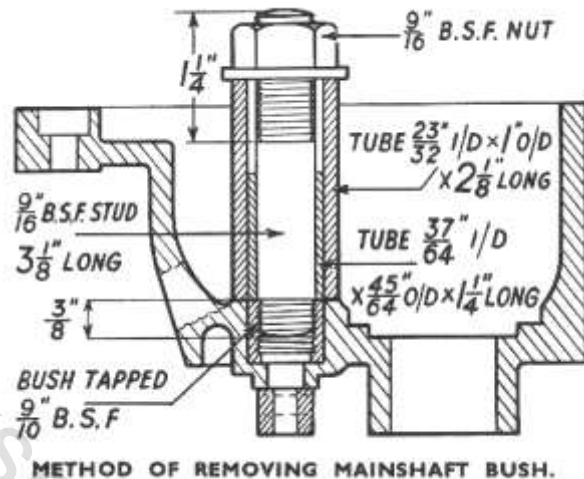
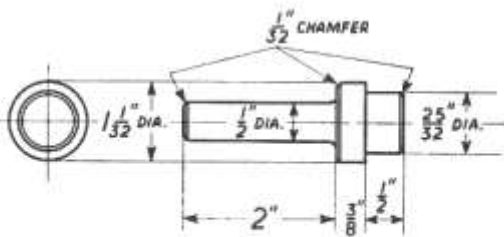

Fig. 25

22. Refitting Gearbox Bearings.

When replacing the gearbox main ball bearing it is most important to support the case on a fixture such as is shown in Fig. 26. A drift such as is shown in Fig. 28 should be used to apply the pressure to the race.



DRIFT FOR REMOVING GEARBOX MAIN BALL BEARING.

Fig. 28

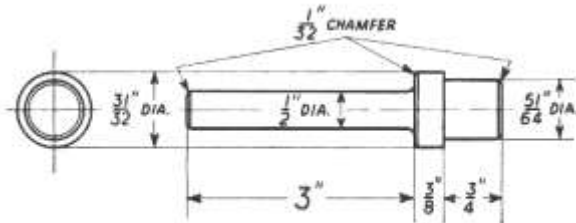

DRIFT FOR REMOVING OR REFITTING KICKSTART SPINDLE BUSH.

Fig. 24

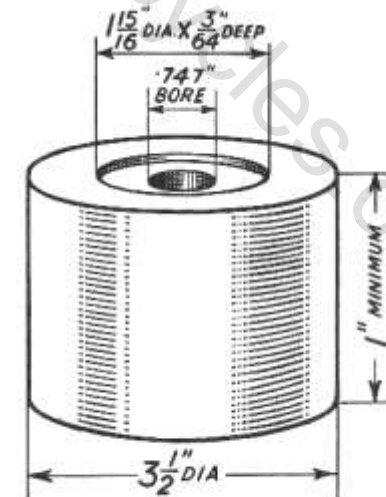

FIXTURE FOR REPLACING GEARBOX MAIN BALL BEARING.

Fig. 26

ROYAL ENFIELD WORKSHOP MANUAL

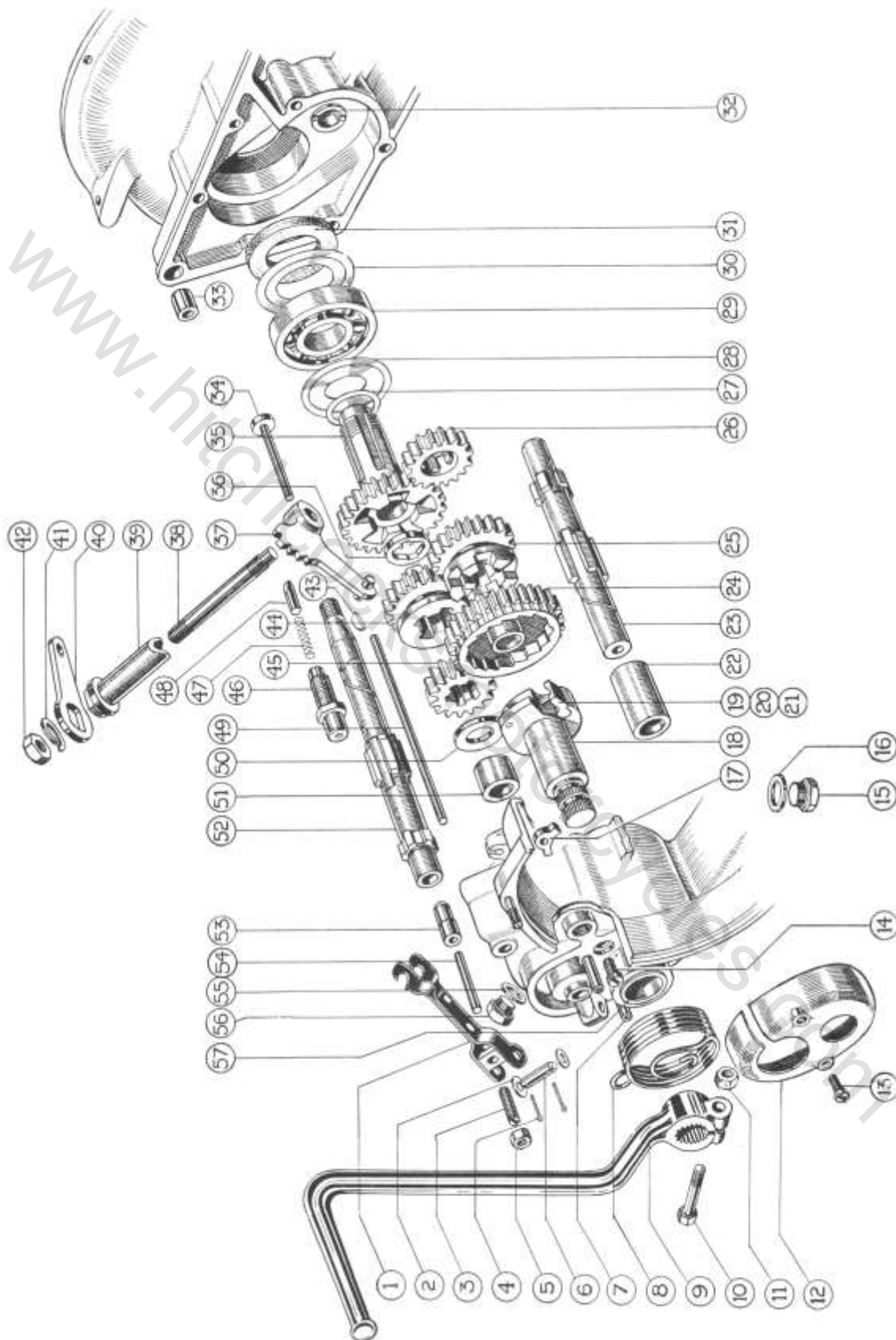

ROYAL ENFIELD WORKSHOP MANUAL

- | | |
|---|--|
| (1) Clutch Operating Lever. | (30) Gearbox Mainshaft Bearing Felt Washer Retainer. |
| (2) Clutch Operating Lever Pivot Washer. | (31) Gearbox Mainshaft Bearing Felt Washer. |
| (3) Clutch Operating Lever Adjusting Screw. | (32) Layshaft Bush (in Shell). |
| (4) Clutch Operating Lever Pivot Split Pin. | (33) Crankcase Dowel. |
| (5) Clutch Operating Lever Adj. Screw Nut. | (34) Clutch Operating Rod Pad. |
| (6) Clutch Operating Lever Pivot. | (35) Mainshaft High Gear (26 T.). |
| (7) Clutch Operating Lever Cover Post. | (36) Splined Thrust Collar (Main Shaft High Gear). |
| (8) Kickstarter Crank Return Spring. | (37) Gear Operator (Inside). |
| (9) Kickstarter Crank. | (38) Gear Operator Spindle. |
| (10) Kickstarter Crank Clamp Bolt. | (39) Gear Operator Lever Sleeve. |
| (11) Kickstarter Crank Clamp Bolt Nut. | (40) Gear Operator Lever (Outside). |
| (12) Clutch Operating Lever Cover. | (41) Gear Operator Lever Spring Washer. |
| (13) Clutch Operating Lever Cover Screw. | (42) Gear Operator Lever Nut. |
| (14) Kickstarter Stop and Trip Plate Screw. | (43) Gearbox Mainshaft Key. |
| (15) Gearbox Drain Plug. | (44) Mainshaft Sliding Gear (21 T.). |
| (16) Gearbox Drain Plug Fibre Washer. | (45) Mainshaft Small Gear (15 T.). |
| (17) Kickstarter Stop and Trip Plate. | (46) Gear Operator Locating Plunger Bush. |
| (18) Kickstarter Spindle. | (47) Gear Operator Locating Plunger Spring. |
| (19) Kickstarter Spindle Pawl. | (48) Gear Operator Locating Plunger. |
| (20) Kickstarter Pawl Plunger. | (49) Clutch Operating Rod (Long). |
| (21) Kickstarter Pawl Plunger Spring. | (50) Plain Thrust Washer (Mainshaft Low Gear). |
| (22) Layshaft Bush in Kickstarter Spindle. | (51) Gearbox Mainshaft Bush. |
| (23) Layshaft. | (52) Gearbox Mainshaft. |
| (24) Layshaft 1st Gear and Kickstarter Wheel (27 T.). | (53) Clutch Operating Rod Bush (in Mainshaft). |
| (25) Layshaft Sliding Gear (21 T.). | (54) Clutch Operating Rod, Short. |
| (26) Layshaft Small Gear (16 T.). | (55) Gearbox Oil Filler Plug Washer. |
| (27) Mainshaft Packing Washer (fitted if required). | (56) Gearbox Oil Filler Plug. |
| (28) Gearbox Mainshaft Bearing Oil Retainer. | (57) Kickstarter Spindle Bush. |
| (29) Gearbox Mainshaft Ball Bearing. | |

EXPLODED VIEW OF GEARBOX.
Fig. 27

ROYAL ENFIELD WORKSHOP MANUAL

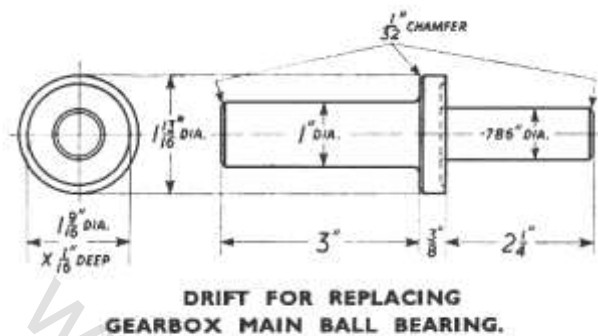

DRIFT FOR REPLACING GEARBOX MAIN BALL BEARING.

Fig. 28

When replacing the kickstarter spindle bush, support the case on a fixture such as is shown in Fig. 29 and use the drift shown in Fig. 24.

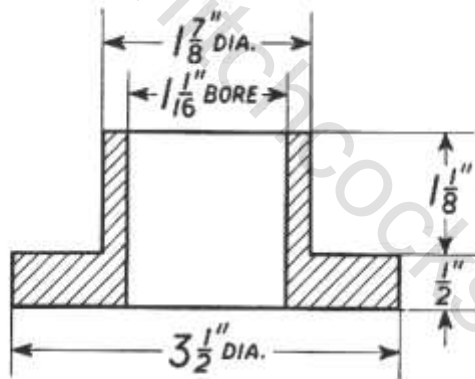

FIXTURE FOR REPLACING GEARBOX KICKSTART SPINDLE BUSH.

Fig. 29

Fig. 30 shows a drift suitable for replacing the mainshaft bush and layshaft bushes in the case and in the kickstarter spindle.

After refitting the bushes they must be reamed to the following sizes :

Kickstarter Spindle Bush	.813 in.
Mainshaft Bush5005 in.
Layshaft Bushes5005 in.

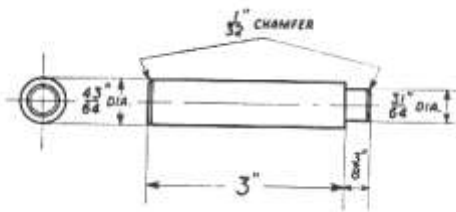

DRIFT FOR REPLACING GEARBOX SMALL BUSHES.

Fig. 30

23. Reassembly of Gearbox.

The exploded view of the gearbox shown in Fig. 27 clearly illustrates the correct positions of the components. Note that the 15 T. pinion fits on the mainshaft and the 16 T. pinion on the layshaft. Note also that the two 21 T. pinions are not identical, that for the mainshaft has the dogs at the same end as the gear teeth while that for the layshaft has the dogs at the opposite end. The 21 T. mainshaft gear must be assembled with the dogs adjacent to the 26 T. mainshaft high gear and the 21 T. layshaft gear must be assembled with the dogs adjacent to the 27 T. first gear and kickstarter wheel.

If it has been necessary to fit a new kickstarter spindle (18) or a stop and trip plate (17) make sure that the spindle clears the kickstarter stop and trip plate inside the kickstarter side of the crankcase. If the new spindle fouls the trip plate, grind the surplus metal away from the kickstarter spindle. Do not remove metal from the stop and trip plate, otherwise it may fail to trip the kickstarter spindle pawl out of engagement when the kickstarter spindle is returned against the stop. In this case it will be found impossible to wheel the machine backwards with any gear engaged, even with the clutch lifted.

Insert the gears and shafts in the kickstarter side of the case and make sure that the two pegs formed on the inside gear operator (37) engage with the grooves in the 21 T. sliding pinions before replacing the driving side of the crankcase. Do not forget to replace the short piece of the clutch push rod (54) before refitting the clutch operating lever cover (12).

When reassembling the gearbox it should be packed about a quarter full of soft grease with engine oil added after assembly.

CLUTCH.

24. Dismantling and Reassembly of Clutch.

The clutch is clearly illustrated in Fig. 7 (page 8), and the method of dismantling it is described in Para. 11.

If new cork inserts are required these must be faced down after assembly to a thickness of 3/8 in., taking care that the thickness of cork is equal on both sides of the plate.

25. Adjustment of Clutch Control.

It is essential that the clutch control has about 1/16 in. free movement (see Fig. 31). Adjustment is provided at two points, i.e., the screwed nipple on the end of the control cable and the set screw and locknut at the lower end of the lever. The set screw should be adjusted so that the lever is approximately vertical (viewed from the back of the machine) when the clutch is fully lifted. The screwed nipple should then be adjusted to give the necessary amount of slack in the control wire. If the set screw is screwed in too far it will not push squarely on the clutch push rod and the clutch will be hard to operate. If the set screw is screwed out too far the travel of the lever may be limited with the result that the control will push up solid before the handlebar lever touches the bar. Even if this gives sufficient movement to free the clutch it is liable to cause a breakage of the clutch control cable unless great care is exercised.

ROYAL ENFIELD WORKSHOP MANUAL

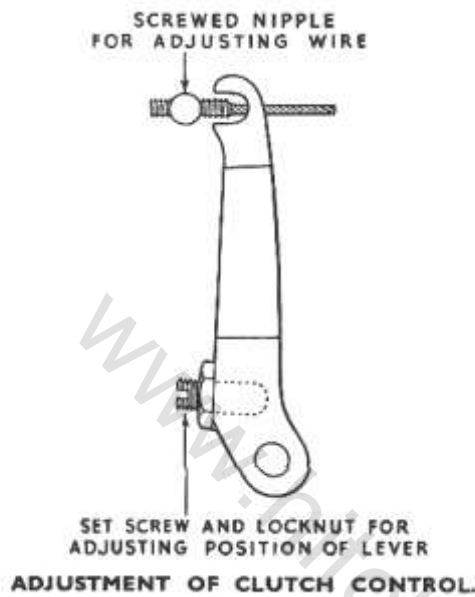

Fig. 31

CHAINS

26. Lubrication.

The front chain is lubricated by partially filling the oilbath case with soft grease and then adding engine oil up to the level of the overflow plug. The rear chain should be lubricated regularly by the driver but, if it is dry or dirty, must be removed, thoroughly washed in paraffin and soaked in engine oil or melted grease to which a little graphite has been added.

27. Tensioning.

There is no means of tensioning the front chain, which will give a very long life if it is always kept correctly lubricated. It should have approximately $\frac{1}{4}$ in. free movement up and down when new and should be replaced when the amount of free movement is greater than $\frac{3}{4}$ in. If the tension varies in different parts of the chain, check at the tightest point.

The rear chain should have approximately $\frac{1}{2}$ in. free movement up and down at the tightest point. To adjust the rear chain loosen the wheel spindle nuts and

adjust by means of the chain adjusters which bear against each fork end. Take care to turn each adjuster equally, otherwise the wheel will be thrown out of alignment. The rear brake may require adjustment after tensioning the chain.

28. Limits of Wear.

A chain is considered to be worn out when its length under load is 2% longer than the length of a new chain of the same type with the same number of links. For the rear chain this means an increase in length of 1 in. The load applied when measuring should be 28 lbs. The primary chain cannot be run up to its limit of wear owing to the lack of adjustment and must be renewed in accordance with the instructions given in Para. 27.

29. Removal, Repair and Replacement.

Both chains are fitted with spring links to facilitate removal. The springs can be removed with the fingers or with the aid of a pair of pliers.

If it is required to replace any of the links in a chain (as, for example, in the unlikely event of a roller or rollers having broken), two adjacent rivets passing through the same outer plate must be removed. To do this, use a rivet extractor or support the chain on two small nuts ($\frac{1}{4}$ in. or $\frac{3}{16}$ in. diameter) and drive the rivets out with a small punch. When replacing riveted links, support the under side of the chain on a flat piece of steel and drive the outer plate over the rivets by means of a hollow punch (or small nut) applied over each rivet in turn. Hammer the ends of the rivets over lightly, taking care not to distort the outer plate so as to cause a tight joint. *Never join together new and badly worn lengths of chain.*

When replacing the chains make sure that the open ends of the spring connecting links point away from the direction of travel. The back half of the connecting link is easily inserted in the rear chain if the ends of the chain are brought together on the rear sprocket. In the case of the front chain, however, the connecting link must be inserted in the straight run of the chain as there is insufficient clearance behind the sprockets to allow the link to be inserted. It will be found that the link can be inserted much more readily if the ends of the chain are pulled together by a pair of round-nosed pliers or similar tool or by a loop of fine string.

ROYAL ENFIELD WORKSHOP MANUAL

WHEEL

30. Removal and Replacement.

To remove the front wheel place the machine on the central stand, disconnect the brake control from the lever on the brake cover plate, unscrew the wheel spindle nuts and spring the forks slightly open when the wheel will drop out.

To remove the rear wheel, place the machine on the central stand, disconnect the rear chain at the spring link and pull it off the rear sprocket, remove the wing nut from the brake rod, loosen the wheel spindle nuts, pull the wheel out backwards clear of the slotted fork ends and then raise the machine slightly to enable the wheel to be lifted clear of the rear mudguard.

When replacing the front wheel make sure that the fork girder enters the space between the brake cam spindle and the stop peg on the cover plate. Do not forget to couple up the brake control.

When replacing the rear wheel make sure the peg on the inner side of the chainstay enters the slotted end in the torque arm attached to the brake cover plate. Note that the chain adjusters are fitted outside the fork ends. Make sure that the wheel is pushed right forward in the slots as far as the chain adjusters will allow. Do not forget to replace the wing nut on the brake rod and adjust the brake control correctly.

31. Tyres.

The tyres should be examined carefully for cuts and excessive or uneven wear ; also for signs of under inflation, such as cracked side walls or damaged fabric.

When removing the tyre always start close to the valve and see that the edge of the cover at the other side of the wheel is well down into the well in the rim. When replacing the tyre, fit the part by the valve last. If the correct method of fitting and removal of the tyre is adopted, it will be found that the covers can be manipulated quite easily with the small levers in the tool kit.

32. Rims.

Rims which are running slightly out of truth can be trued up by tensioning the spokes, but if the rims are badly buckled, twisted or dented they must either be straightened or new ones fitted. Buckled rims cannot be trued without tightening some of the spokes excessively.

33. Spokes.

Examine the wheels for broken or loose spokes and replace or tighten. Loose spokes are liable to break owing to the load coming on them suddenly as the wheel revolves. Loose or broken spokes throw an undue strain on the other spokes in the vicinity.

34. Brakes. (See Figs. 32 and 33).

The brake drums and linings require cleaning from time to time to ensure that there is direct contact between the lining and the drum. The presence of grease, moisture, mud or even dry dust will impair the efficiency of the brake. To dismantle the brake remove the wheel from the machine, remove the right hand spindle nut completely and unscrew the distance piece which fits on the spindle between the inside of the fork end and the brake cover plate. The cover plate can then be lifted off complete with the operating cam and lever and shoes. Remove the two tension springs between the brake shoes and lift the shoes away.

The colour of the linings varies from deep yellow to dark brown according to the severity with which they have been used and the temperature at which they have been running. *Their appearance should be Polished.* Do not rough up the linings with a file in order remove the normal polished surface. The removal of this merely shortens the life of the lining. The presence of grease or mud will probably be shown by dull black streaks on the linings. The best way to remove these is to scrape them off with a knife or hacksaw blade then to reassemble the brake and run the machine for a short period in second gear with each brake is turn, hard on. This will burn out the last traces of grease and will be found to restore the efficiency of the brake once the linings have cooled down. Alternatively grease can be burnt out of the linings with the aid of a blow lamp. Washing the linings with petrol usually results in washing the grease into them and is not recommended.

If new linings are necessary, make sure that those fitted are the correct size and type. The lining material for both brakes is Ferodo M.W. and the dimensions the rear wheel are 5 ins. diameter by 5/8 in. wide by 3/16 in. thick and for the front wheel 3.3/4 ins. diameter by 31/64 in. wide by 1/8 in. thick. When fitting new linings, secure the rivets at the ends of the linings last, so as to avoid buckling the lining.

The brake cam, cam bearing and the pivot pin should be lightly smeared with grease before reassembling the brake if this has been dismantled for cleaning or any other purpose.

35. Wheel Bearings (See Figs. 32 and 33).

The wheels are fitted with non-adjustable ball bearings SKF 6200. If these develop an appreciable amount of play, they must be removed and replaced.

To remove the bearings, first take the wheel out of the machine, then remove all nuts and locknuts from the spindle and drive the spindle out of the hub with a wooden

ROYAL ENFIELD WORKSHOP MANUAL

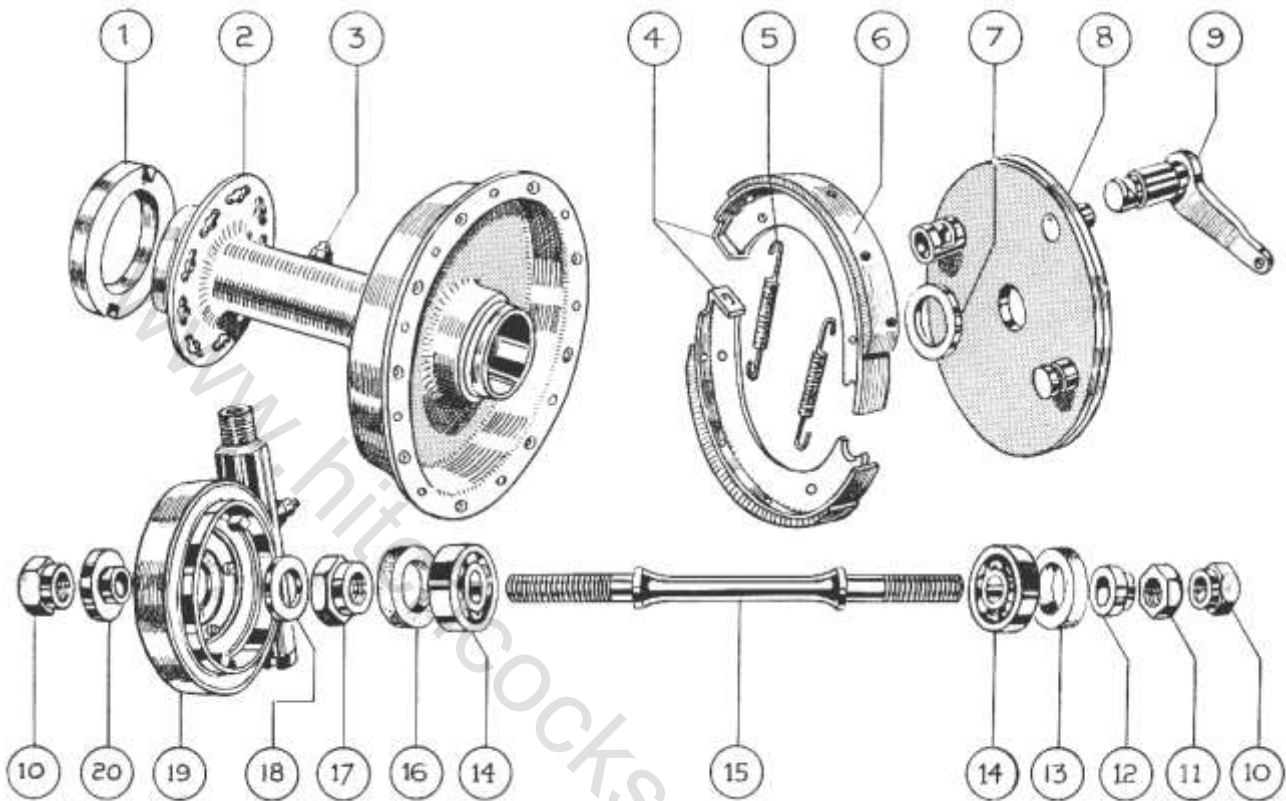

- | | |
|--|---|
| (1) Speedo Driving Ring. | (11) Lock Nut. |
| (2) Front Hub. | (12) Distance Collar (behind brake plate). |
| (3) Grease Nipple. | (13) Oil Retainer 3/16 in. thick. |
| (4) Front Brake Shoes. | (14) Ball Bearing S. K. F. 6200. |
| (5) Front Brake Return Spring. | (15) Spindle. |
| (6) Front Brake Lining. | (16) Oil Retainer 5/32 in. thick. |
| (7) Packing Washer (fitted if required). | (17) Ball Bearing Retaining Nut, Flange Side. |
| (8) Front Brake Cover Plate. | (18) Packing Washer. |
| (9) Cam and Lever. | (19) Self-contained Speedometer Gearbox. |
| (10) Spindle Nut. | (20) Distance Collar (outside gearbox plate). |

EXPLODED VIEW OF FRONT HUB.

Fig. 32

ROYAL ENFIELD WORKSHOP MANUAL

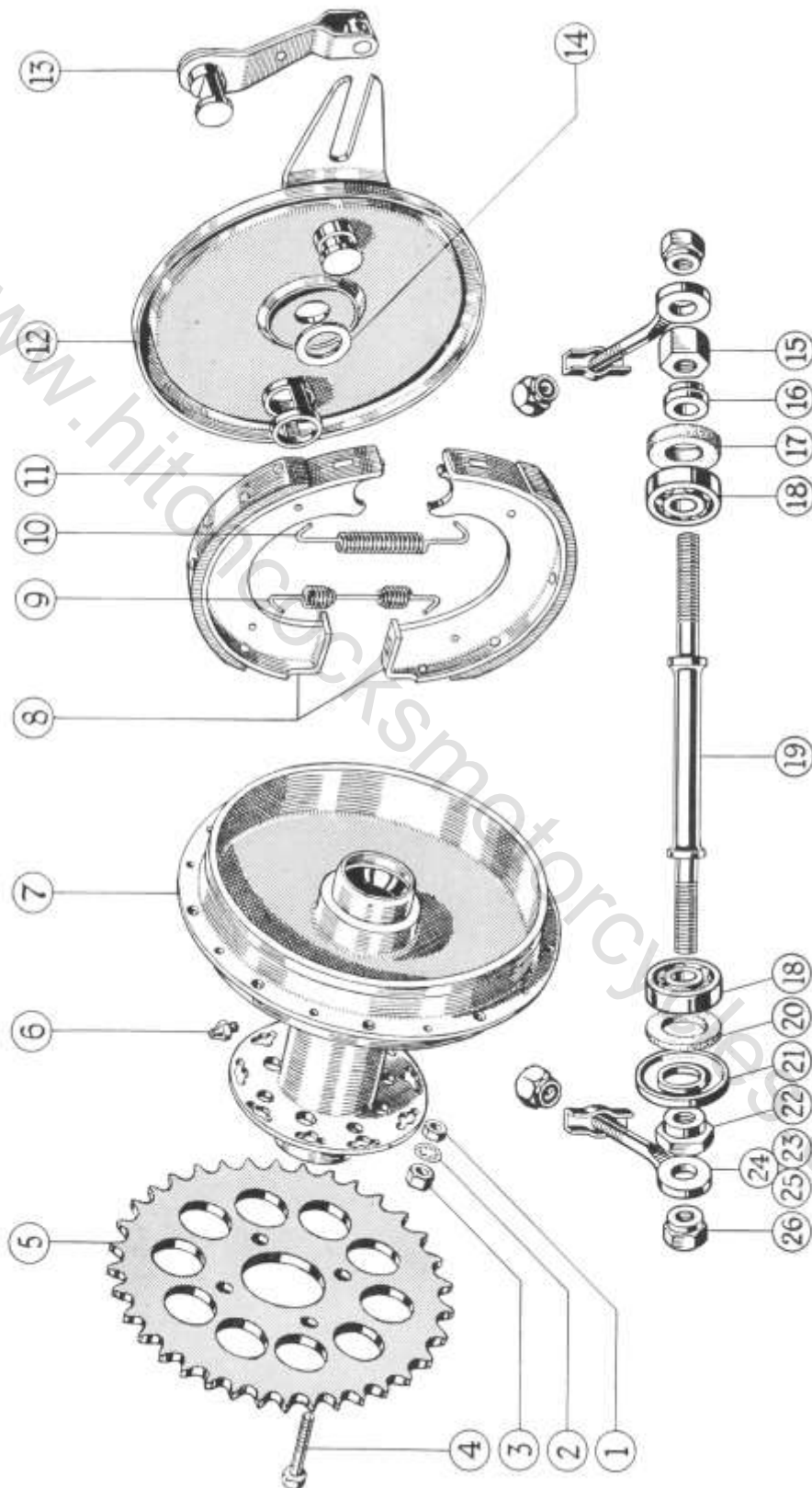

ROYAL ENFIELD WORKSHOP MANUAL

- | | | |
|--|---|------------------------------------|
| (1) Sprocket Bolt Locknut. | (10) Rear Brake Shoe Return Spring, Pivot Side. | (18) Ball Bearing SKF6200. |
| (2) Sprocket Bolt Shakeproof Washer. | (11) Rear Brake Shoe Lining. | (19) Spindle. |
| (3) Sprocket Bolt Nut. | (12) Rear Brake Cover Plate. | (20) Oil Retainer, 5/32 in. thick. |
| (4) Sprocket Bolt. | (13) Rear Brake Cam and Lever. | (21) Dust Excluder. |
| (5) Sprocket, 34 T. | (14) Brake Plate Packing Washer (fitted if required). | (22) Ball Bearing Retaining Nut. |
| (6) Grease Nipple. | (15) Brake Plate Lock Nut. | (23) Driving Chain Adjuster Nut. |
| (7) Rear Hub. | (16) Distance Collar. | (24) Driving Chain Adjuster Plate. |
| (8) Rear Brake Shoe. | (17) Oil Retainer, 3/16 in. thick. | (25) Driving Chain Adjuster. |
| (9) Rear Brake Shoe Return Spring, Cam Side. | | (26) Spindle Nut. |

EXPLODED VIEW OF REAR HUB.

Fig. 33

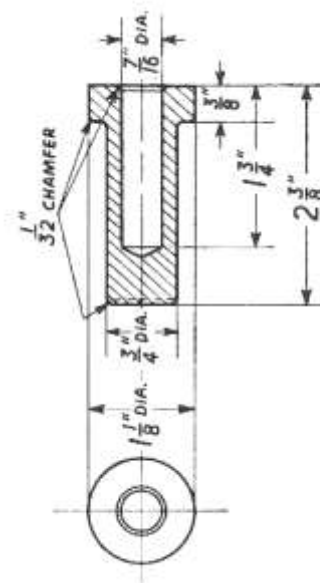

DRIFT FOR FITTING JOURNAL TYPE HUB BEARINGS.

Fig. 34

or leather mallet. This will bring one of the bearings with it, leaving the other one in the hub barrel. The bearing on the spindle can then be driven off and the spindle reinserted in the hub and driven through in the opposite direction, when it will bring the second bearing out of the barrel.

To replace the bearings the drift shown in Fig. 34 will be found suitable. Two of these drifts are required, one being used to support the first bearing after fitting it and the spindle into the hub, while the second one is then used to drive in the second bearing.

The inner faces of the bearings should bear against the shoulders on the spindle just before the outer races bottom in the recesses in the hub barrel. If this is not the case, excessive strain will be placed on the balls when the locknuts are tightened up. If the bearing shows signs of tightening when these nuts are screwed home, a thin shim should be fitted on the spindle between the shoulder and the inner race of one of the bearings.

36. Rear Sprocket. (See Fig. 33).

Make sure that the rear wheel sprocket is securely fastened to the hub. Nuts and locknuts

ROYAL ENFIELD WORKSHOP MANUAL

FRAME AND FORK

37. Petrol Tank.

The petrol tank is attached to the frame by means of two lugs at the rear through which a stud is fitted, passing through the top tube at the point where it is reinforced by the saddle attachment bracket. The front end of the tank is secured by means of two lugs through which is passed a stud which passes through a clip round the front down tube. Note that there is a distance tube inside this clip to prevent it being overtightened.

38. Gear Control Quadrant.

The construction of the gear control quadrant is shown in Fig. 35. By loosening the bolt attaching the quadrant to the tank, the quadrant can be pivoted about its lower attachment bolt and should be so adjusted that when second gear is engaged the lever lies in the second gear position without forcing. The gear lever should be set so that it lies against the back of the slot in the control gate, i.e., the side nearest to the tank. If this is done, the control gate will effectively prevent any possibility of second gear jumping out of engagement.

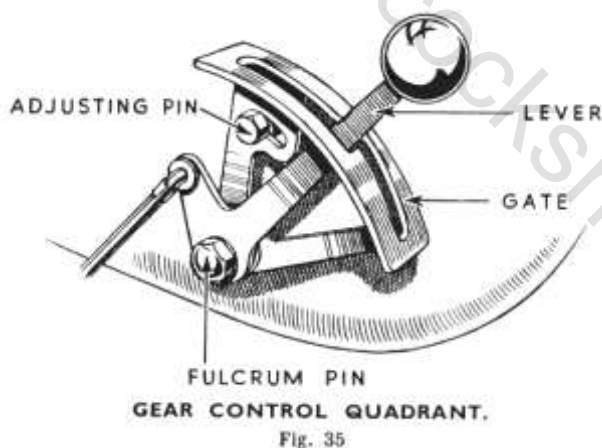

39. Alignment of Wheels.

The only way to make sure that the wheels are in alignment is to check one against the other. Frames and forks are set when built so as to ensure that the centre of the two wheel spindles, the centre line of the engine attachment lugs and the head lug, all lie in the same plane. Individual points along the frame tubes, however, are not checked and the wheel cannot, therefore, be accurately lined up by ensuring that it is central between the chainstays or backstays. Neither can it be assumed that the wheel will be in line when it is pushed hard against the front end of the slots in the rear fork ends.

Wheel alignment can be checked by using a straightedge if one is available. Wooden straight-edges, however, are liable to warp and are, therefore, not reliable. The best way to check the alignment of the wheels is to

use a piece of fine string. This should be tied to one spoke of the rear wheel, taken round the tyre, brought towards the front of the machine and pulled taut with the front end some inches away from the front wheel. The string should then be brought slowly in towards the front wheel, keeping it taut and watching carefully to see when it touches the front portion of the rear tyre. It should just come on to the rear tyre at two points simultaneously with touching the front tyre at two points, assuming that the front wheel is pointing straight ahead. Check the setting by testing with string in the same way along the other side of the machine.

The above method checks only the alignment of the lower portions of the two wheels. If the frame is twisted or the forks are bent, it is possible that the lower portion of the wheels will be in alignment while the upper portion is not. Any serious twist can be seen by looking along the machine to make sure that both wheels lie in the same plane. In case of doubt this can be checked by using the string near the top of the wheel after removal of the mudguards and engine cylinder.

If the wheels are in alignment and the frame is not twisted or bent the rear chain should also be in alignment. This can be checked by looking along it with the chainguard removed. If the chain has been run out of alignment it will show definite indications on the sides of the sprocket teeth and on the inner faces of the chain links. If the wheels cannot be lined up without throwing the chain out of alignment, the probable cause is the rear portion of the frame is bent.

40. Adjustment of Steering Head.

To check for play in the steering head the weight must be taken off the front wheel by placing the machine on the stand and lifting at the lower ends of the fork. Any play in the steering head can then be felt by placing one finger across the head races just beneath the ball head clip. The steering head should be adjusted so as to have the minimum of play in it, while, at the same time, the fork must swing easily to either side when the handlebars are given a slight tap with the front wheel lifted clear of the ground.

To adjust the head bearing loosen the nut on the pinch bolt through the ball head clip (see Fig. 36) and adjust by means of the large nut on top of the ball head clip. Remove as much play as possible without interfering with the free movement of the steering head. *Do not forget to tighten the pinch bolt nut* after making adjustment. This takes the strain off the thread, in the top adjusting nut and failure to tighten the pinch bolt may cause the thread in the adjusting nut to strip with serious consequences.

41. Dismantling and Reassembling Steering Head.

To dismantle the steering head, raise the front of the machine by placing a suitable box beneath the engine (unless the front wheel or forks have already been removed), disconnect the control cables from the clutch, decompressor (see Para. 2), front brake lever and from the throttle twist grip. Unscrew the handlebar expander bolt two or three turns and tap it sharply downwards into the

ROYAL ENFIELD WORKSHOP MANUAL

stem to loosen the wedge inside the handlebar stem. The handlebar can now be withdrawn from the steering stem. Now remove the large nut from the top of the steering stem, loosen the pinch bolt (see Fig. 36) and drive the projecting end of the steering stem through the ball head clip. Lift the ball head clip away in a forward direction and withdraw the steering stem complete with the forks and wheel (if not already removed) from the lower end of the head lug.

When replacing the steering stem and forks assemble the lower race on to the steering stem with clean grease round the balls. Note that there are only 22 balls in each race. Do not attempt to fit an extra ball. Insert the steering stem upwards through the head lug, place the upper ball race and balls in position and knock the ball head clip down on to it, then screw down the head bearing adjusting nut until the adjustment is correct and lock up the pinch bolt nut. Replace the handlebar in the steering stem, set it square with the wheel, tighten the expander bolt and re-connect the control cables.

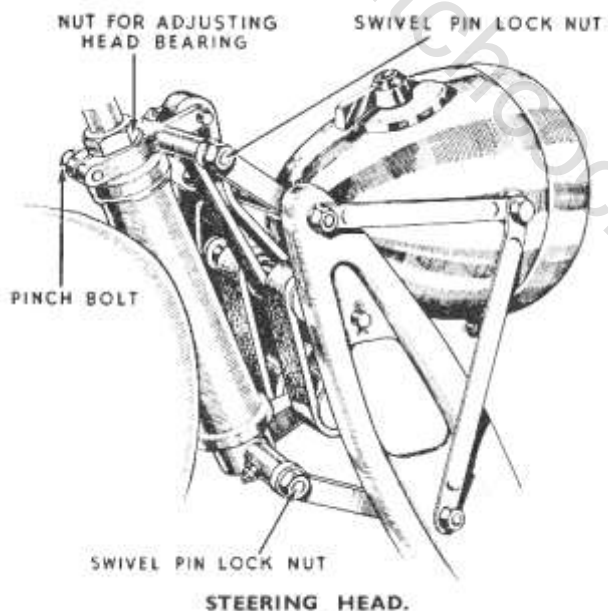

Fig. 36

42. Adjustment of Fork Links.

Side play in the front fork swivel pins should be eliminated as far as possible without interfering with the free movement of the forks. The two rear swivel pins are threaded into the links on the right-hand side of the machine and adjustment is made by loosening the lock nuts and turning the heads of the swivel pins. (See Fig. 36). Check the adjustment after tightening the locknuts.

No adjustment is provided for the front swivel pins, each of which has a plain centre portion of larger diameter than the threaded ends and a few thousandths of an inch longer than the tubular portion of the fork links.

43. Replacing Fork Suspension and Rebound Rubbers.

(See Fig. 37).

If the fork suspension rubber bands have worn or stretched badly they can be removed by withdrawing the centre (25) and top (21) spindles round which the bands pass, after removal of the split pin from one end of each spindle.

When replacing a complete set of rubber bands the following procedure will be found the most convenient.

Remove the two nuts securing the top lamp bracket to the fork girders, slacken the lower nuts and swing the lamp forward. Place the machine on the stand and allow the forks to drop to their full extent, insert the centre spindle (25) through, say, the left-hand fork side and thread over it one of the short distance bushes (26) and the spacing washer (27). Place two of the main suspension rubbers over the spindle, fitting one over the rubber sleeve (11) on the fork crown (8) and leaving the other one loose between the inside of the left-hand fork girder and the washer (10) outside the rubber sleeve on the fork crown. Now thread the long distance bush (28) and the long rubber sleeve (29) over the centre spindle. Place the narrow suspension band in position, followed by the other two main suspension bands, one in position over rubber bushes on the centre spindle and the fork crown and the other alongside it between it and the inside of the right-hand fork girder. Thread the centre spindle through the second distance washer (27) and short distance bush (26). If difficulty is experienced in doing this, spring the girders outwards slightly. Drive the centre spindle right home through the right-hand fork girder, secure it with the split pin. The fork now has two of the main suspension bands in position with the other two lying loosely outside them and the narrow band loosely between them. Now push the machine off its stand, sit on the saddle and push down hard on the handlebars at the same time pulling upwards on the narrow suspension band by means of a piece of stout string looped through it. This string can be secured by winding it round the handlebar expander bolt, leaving both hands free to insert the small metal bush (23) and rubber sleeve (24) inside the narrow suspension band and in position between the two jaws formed on the front of the ball head clip (3). Having done this insert the top spindle (21) and secure it with a split pin.

Put the machine on the stand again, push the fork well down and work the two loose main suspension bands over the two which are already in position. The outer bands will slip over the inner ones more easily if the contacting surfaces are damped, but even if they are dry they will be found to go into place quite easily if all tension is taken off them by pushing the fork well down. Refit the lamp brackets to the fork girders and tighten the nuts securely.

Note. If it is required to change the main suspension bands on one side of the fork only, do not disturb the narrow suspension band. Slip the outer rubber on the other side of the fork off the inner rubber, remove the split pin from the end of the centre spindle on the side of the fork on which the bands require replacing and tap the spindle through far enough to allow the short distance piece to be removed and the band or bands to be changed.

ROYAL ENFIELD WORKSHOP MANUAL

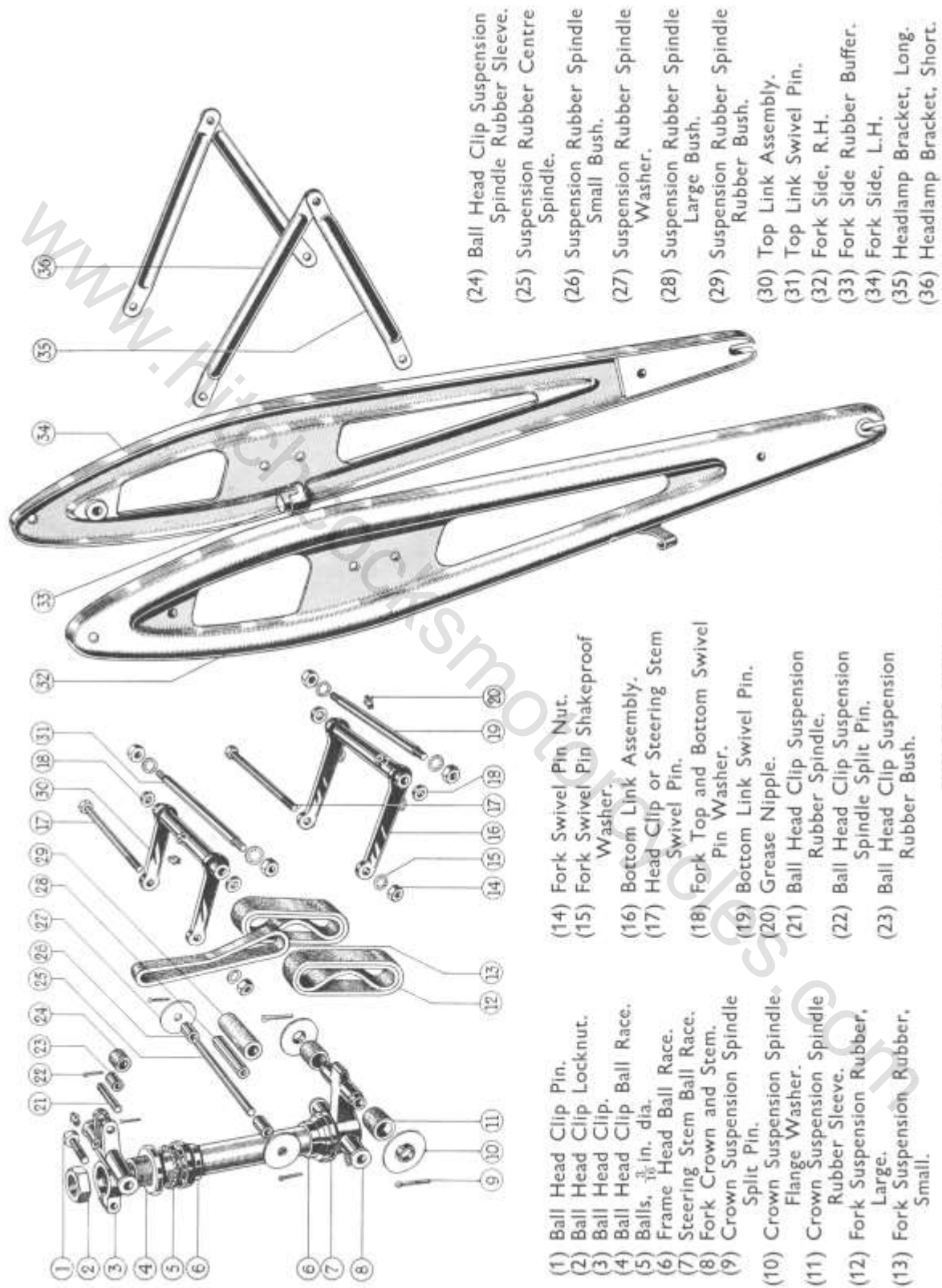

EXPLODED VIEW OF FRONT FORK.
FIG. 37

ROYAL ENFIELD WORKSHOP MANUAL

44. Dismantling the Front Fork.

The construction of the forks is clearly shown in Fig. 37. To dismantle the forks, after removal of the rubber bands, as described in Para. 43, unscrew the wheel spindle nuts, the nuts securing the lamp brackets to the fork girders and the bolts and nuts securing the mudguard and mudguard stays to the girders. The fork sides can now be removed, after which the fork links can be removed from the ball head clip and steering stem by unscrewing the nuts on the right-hand side and then unscrewing the spindles and withdrawing them.

45. Handlebar Control Levers. (See Fig. 38).

The clutch, front brake and decompressor levers must all work freely on their pivots. The twist grip must have sufficient friction to prevent the throttle closing when the driver's hand is removed from the grip.

To adjust the twist grip friction on earlier models, remove the complete twist grip by loosening the screw securing the aluminium cable stop to the handlebar, disconnecting the control cable and sliding the twist grip and cable stop off the handlebar. It will then be seen that the end of the handlebar is saw-cut and fitted with an expander screw which can be tightened one or two turns before refitting the twist grip.

In the case of later machines, the plug in the end of the handlebar through which the expander screw fits is provided with a flanged head which prevents removal of the twist grip and relieves the cable stop and twist grip flange from side strain if the twist grip is pulled endways. To adjust the friction of the twist grip in this case, loosen the screw securing the cable stop as before, then push the twist grip and cable stop on to the bar as far as they will go, thus exposing the expander screw in the end of the handlebar.

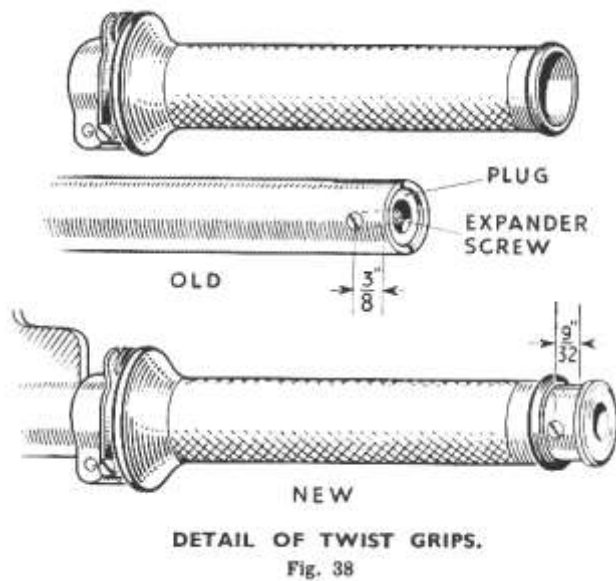

Tighten the screw and pull the twist grip back into place before securing the cable stop clip. If it is necessary to remove this type of twist grip completely, proceed as follows :

Loosen the screw securing the cable stop clip, disconnect the control wire and push the twist grip and cable stop on to the bar as far as they will go. Now unscrew the expander screw completely and pull the plug out of the end of the handlebar, after which the twist grip and cable stop can be withdrawn from the bar.

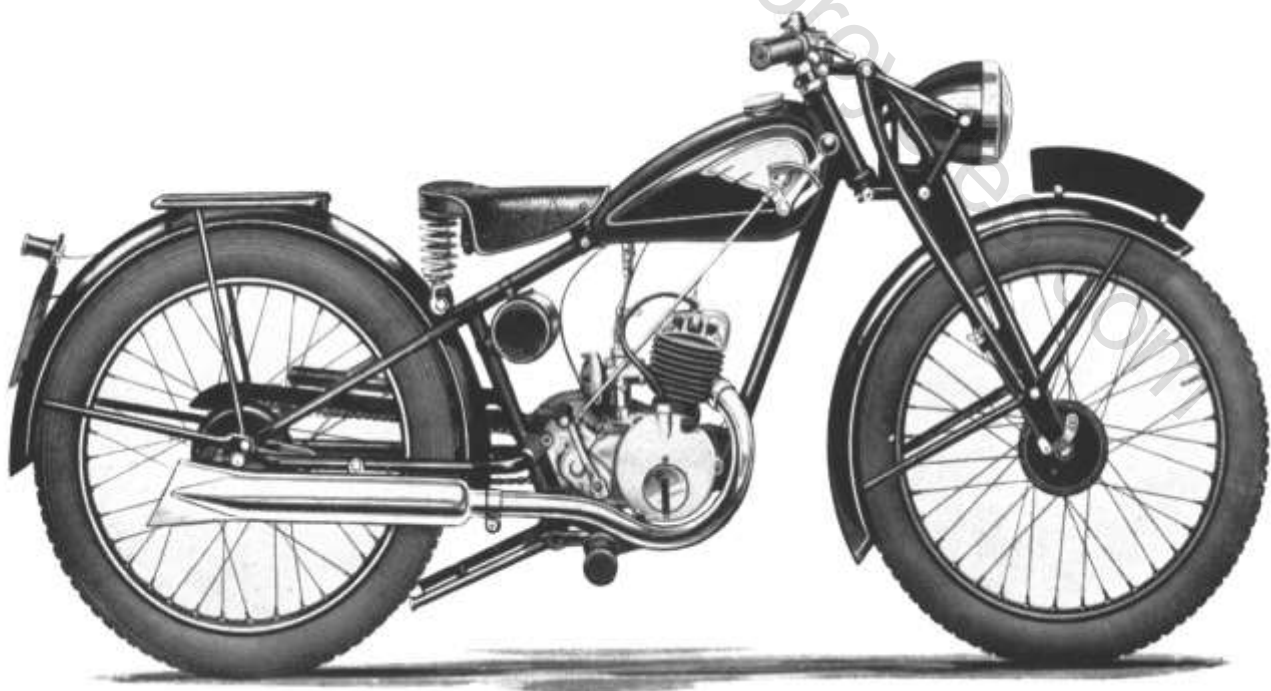

ROYAL ENFIELD WORKSHOP MANUAL

CARBURETTOR

Complete AMAL Carburettor Type 223/001 CD.
Carburettor less Strangler Unit Type 223/001 C.

Strangler Unit only Type 224/100.
Mixing Chamber only Type 223/001.

46. General Description.

The carburettor is of the taper needle type similar to that used on the larger Royal Enfield motor cycles. The following differences should, however, be noted: (1) The float chamber is integral with the mixing chamber; (2) there is no pilot jet or adjustable air control for slow running; (3) there is no air slide. Fig. 39 shows a general view of the outside of the carburettor. It will be seen that a large shutter type air strangler is fitted to facilitate starting from cold. An air filter is fitted immediately behind the strangler. The float chamber is of the top-feed type.

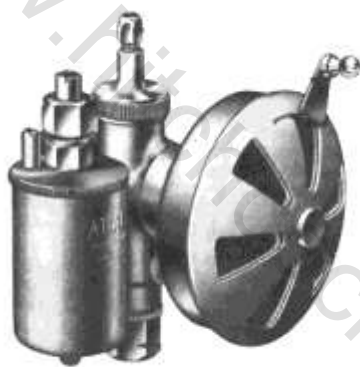

GENERAL VIEW OF CARBURETTOR.

Fig. 39

47. Construction of Carburettor.

Fig. 42 shows a section through the carburettor which makes its construction quite clear. To withdraw the throttle slide (15) unscrew the knurled mixing chamber top (11). The taper needle (19) is held in the throttle slide (15) by means of a spring clip (14) which is held in place by the throttle return spring (12) (see Figs. 40, 41 and 42). Access to the main and needle jets (21 and 18) is obtained by unscrewing the jet plug (22) at the bottom of the mixing chamber. The float (2) is secured to the float needle (1) by

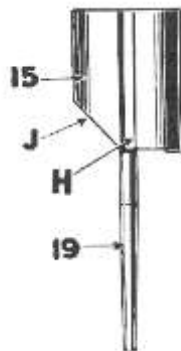

THROTTLE SLIDE.

Fig. 41

means of a clip soldered to the top of the float and engaging in a groove in the float needle

48. Method of Tuning.

Main Jet. This affects the mixture strength from about three-quarters to full throttle but has little or no effect at smaller throttle openings. The standard jet is No. 90 and it is unlikely that any alteration will be required.

Needle and Needle Jet. The taper needle working up and down in the needle jet as the throttle is opened and closed controls the mixture strength over the range of throttle openings most often used, i.e., from say one quarter to three-quarters open. The needle can be raised or lowered in the throttle slide thus regulating the mixture strength. Raising the needle richens the mixture, lowering it weakens the mixture. To alter the position of the needle, disconnect the throttle slide from the control wire and spring. Then push the needle and clip (see fig 41) out of the slide,



TAPER NEEDLE AND CLIP.

Fig. 41

spring the clip off the needle and replace it one groove higher or lower as required. Replace the needle and clip in the slide and couple up to the control wire and spring, finally replacing the slide in the carburettor body.

The standard setting for the needle is with the clip in No. 3 groove (counting from the top). After the engine is fully run in it may tend to four-stroke more than is desirable, in which case the taper needle should be lowered by refitting the clip in No. 2 groove.

The needle jet size is No. 107.

Throttle Slide. The shape of the lower edge of the throttle slide affects the mixture at throttle position up to about one-quarter open. When the engine is idling the mixture is controlled mainly by the depth of the step formed on the bottom of the slide. This determines the air space over the jet for a given throttle opening and at very small throttle openings has considerable effect on the suction on the jet. At slightly larger throttle openings the mixture is controlled mainly by the shape of the cutaway at the back of the throttle slide (J on Fig. 40). The steeper the slope the weaker will be the mixture and vice versa.

ROYAL ENFIELD WORKSHOP MANUAL

There is a number stamped on the bottom of the slide which indicates the amount of the cutaway—the higher the number the greater the slope of the cutaway. The standard throttle valve has No. 5 cutaway and a step 1/32 in. deep. It is unlikely that any modification of this throttle valve will be required and it is, perhaps, necessary to issue a warning against filing the valve in an attempt to obtain perfect two-stroking when idling.

49. Carburettor Troubles.

This carburettor is so simple that trouble with it is very unlikely. It is designed to use a reasonably large jet so that choked jets are very rare since any particles which will pass the filter in the tank will also pass the jet. In the case of new machines, however, it occasionally happens that a piece of cork from the petrol tap lodges either in the main jet or at the fuel needle seat (A. Fig. 42).

Another possible trouble is that an accumulation of fine silt passes the filter and collects in the recess at the bottom of the float chamber, thus preventing the fuel needle from dropping. If this occurs it will be found impossible to flood the carburettor and any attempt to do so will result in the float being pushed down the needle thus cutting off the feed altogether. The remedy is to unscrew the float chamber lid, remove the float and float needle, insert a small twist drill in the recess at the bottom of the float chamber and twist it between the finger and thumb. This will clear the accumulated silt out of the recess. When reassembling the float chamber make sure that the spring clip on the float engages with the groove in the float needle.

If the carburettor floods the cause is either (a) the tickler sticking; (b) a bent float needle (c) dirt on the float needle seating, or (d) a punctured float. Never use grinding compound to lap the needle on to its seating, only rub it in lightly by twisting between the finger and thumb.

50. Air Cleaner.

The air cleaner behind the carburettor should be cleaned by washing in petrol about every 2,000 miles. The gauze should then be dipped in oil and allowed to drain, though this is not absolutely necessary since it will very soon become wet with oil from the blow back from the engine. A certain amount of blow back occurs with all two-stroke engines, and the presence of the gauze screen to catch this is a valuable aid to economy of fuel.

51. Causes of High Petrol Consumption.

If the petrol consumption is excessive first look for leaks either from the carburettor, petrol pipe, petrol tap or tank. The presence of oil in the petrol will readily indicate any small leaks which might otherwise pass unnoticed. Make sure also that the air cleaner is not choked and that the main and needle jets are screwed up tightly. If all the above points are in order it may be necessary to lower the taper needle one notch in the throttle slide or, if they are badly worn, to replace the needle and needle jet. Before doing so, however, make sure that the fault does not lie in the rest of the machine by checking such points as the following :- (a) Brakes binding; (b) chains tight or dry; (c) insufficient oil in gearbox; (d) engine requires decarbonising; (e) ignition timing incorrect; (f) sparking plug defective.

- (1) Float Needle.
- (2) Float.
- (3) Tickler Cotter.
- (4) Tickler Bush.
- (5) Tickler Spring.
- (6) Tickler.
- (7) Petrol Pipe Union Nipple.
- (8) Petrol Pipe Union Nut.
- (9) Float Chamber Cover.
- (10) Cable Adjuster.
- (11) Mixing Chamber Top.
- (12) Throttle Spring.
- (13) Throttle Valve Location Screw.
- (14) Jet Needle Clip.
- (15) Throttle Slide.
- (16) Feed Hole Screw.
- (17) Feed Hole Washer.
- (18) Needle-Jet.
- (19) Jet Needle.
- (20) Jet Plug Washer.

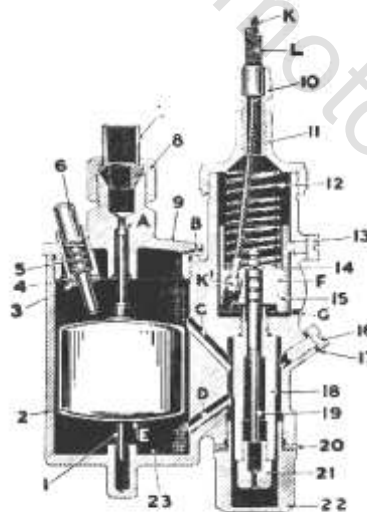

SECTION OF CARBURETTOR.
Fig. 42

- (21) Main Jet.
- (22) Jet Plug.
- (23) Float Chamber.
- A. Petrol Feed Needle Seat.
- B. Air Vent Hole in Float Chamber Cover.
- C. Air Release Passage from Jet Chamber into Float Chamber.
- D. Petrol Feed Passage from Float Chamber to Main Jet.
- F. The choke bore of the Carburettor.
- G. Drain hole from mixing chamber.
- H. Guide groove in the throttle.
- J. Cutaway of the throttle.
- K. Throttle cable.
- K1. Throttle cable nipple.
- L. Throttle cable outer cover.

ROYAL ENFIELD WORKSHOP MANUAL

LIGHTING AND IGNITION

MAGNETO. (Miller Type FL 18.)

52. Operation of the Magneto.

The magneto is of the flywheel type and the following brief description of its operation is given because there appears to be a lack of general understanding as to how this type of magneto operates.

The principle of operation is exactly the same as with the normal rotating armature type of magneto, i.e., a current is generated in the primary windings of the coil due to the relative movement of the coil and magnets. The primary circuit includes a contact breaker with a small condenser in parallel across the contact points. The alternating current flowing in the primary circuit is interrupted at the most suitable moment by opening the contact breaker points and the sudden cessation of this current causes an electric impulse of very high voltage in the secondary windings of the coil which are connected through the H.T. lead to the sparking plug.

The most obvious difference between the flywheel magneto and the rotating armature type is that with the former the coil is stationary and the magnets are moving, whereas with the latter the reverse is the case. This, however, does not affect the principle of operation in any way. With this particular type of flywheel magneto there are six magnetic poles in the flywheel ring, whereas the normal rotating armature magneto has only two poles. This large number of poles, however, is provided only to obtain adequate output from the lighting coils which are mounted, together with the ignition coil, on the inside of the magneto coil plate, but are otherwise quite independent of the ignition system.

The large number of poles makes the timing of the magneto more critical than is the case with a magneto having only two magnetic poles. With all types of magneto a good spark is obtained only if the opening of the contact points occurs when the trailing tip of one of the moving pole pieces has left the tip of one of the fixed pole pieces by a definite angular distance. This angle is naturally much more critical in the case of a six pole system, with only 60° between each pole, than it is with a two pole magneto having 180° between poles.

Another point to note is that a conventional fixed ignition rotating armature magneto is timed by turning the whole armature relative to the engine and has the relation between contact breaker opening and pole position permanently fixed. By contrast the Miller FL 18 flywheel magneto is timed by turning the cam relative to the flywheel which is keyed to the engine shaft. Consequently any alteration of the timing relative to the engine also alters the relative position of the moving and stationary pole pieces at the moment when the contact points open and thus affects the strength of the spark. **It is very important therefore that the magneto should be timed in accordance with the instructions given in paragraph 17.**

The best spark at kickstarter speeds is actually obtained when the contact points open with the pole tips parted by 1/4 in. to 5/16 in. On the earlier engines the keyways in the shaft and flywheel centre were arranged to give this pole

position when the piston is 3/16 before T.D.C. Experience has shown, however, that the timing can be set considerably later without any great loss of spark energy but cannot be set appreciably earlier if a good spark is to be obtained. On the latest magnetos (with 8 rivet holes in the centre flange) the keyway has, therefore, been moved so that the pole tips are now parted by 1/2 in.- 9/16 in. when the piston is at the firing point.

53. Cleaning and Lubrication of Contact Breaker

Mechanism. (See Fig. 43).

Remove contact breaker cover and examine the contacts. If they are dirty, they must be cleaned by with fine carborundum stone or fine emery cloth; afterwards wipe away any dirt or metal dust with a petrol-moistened cloth. Make sure that the contact breaker arm moves freely on its pivot. If it shows any tendency to stick, remove the split pin and fibre washer and also the screw which secures the contact breaker spring to the insulated terminal, the contact breaker arm can then be removed, a trace of oil applied to the pivot pin and the contact breaker arm replaced.

The contact breaker does not require any other lubrication. Take great care to keep grease and oil away from the contact points.

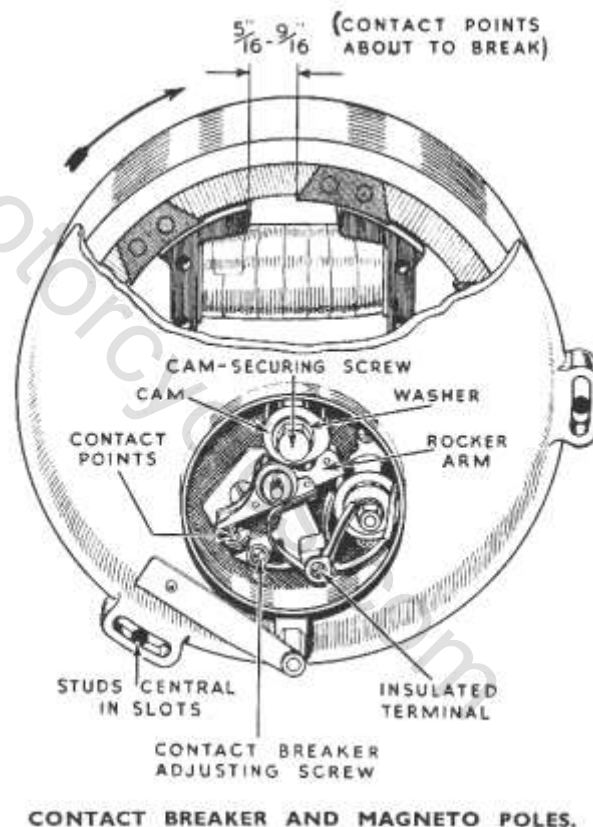
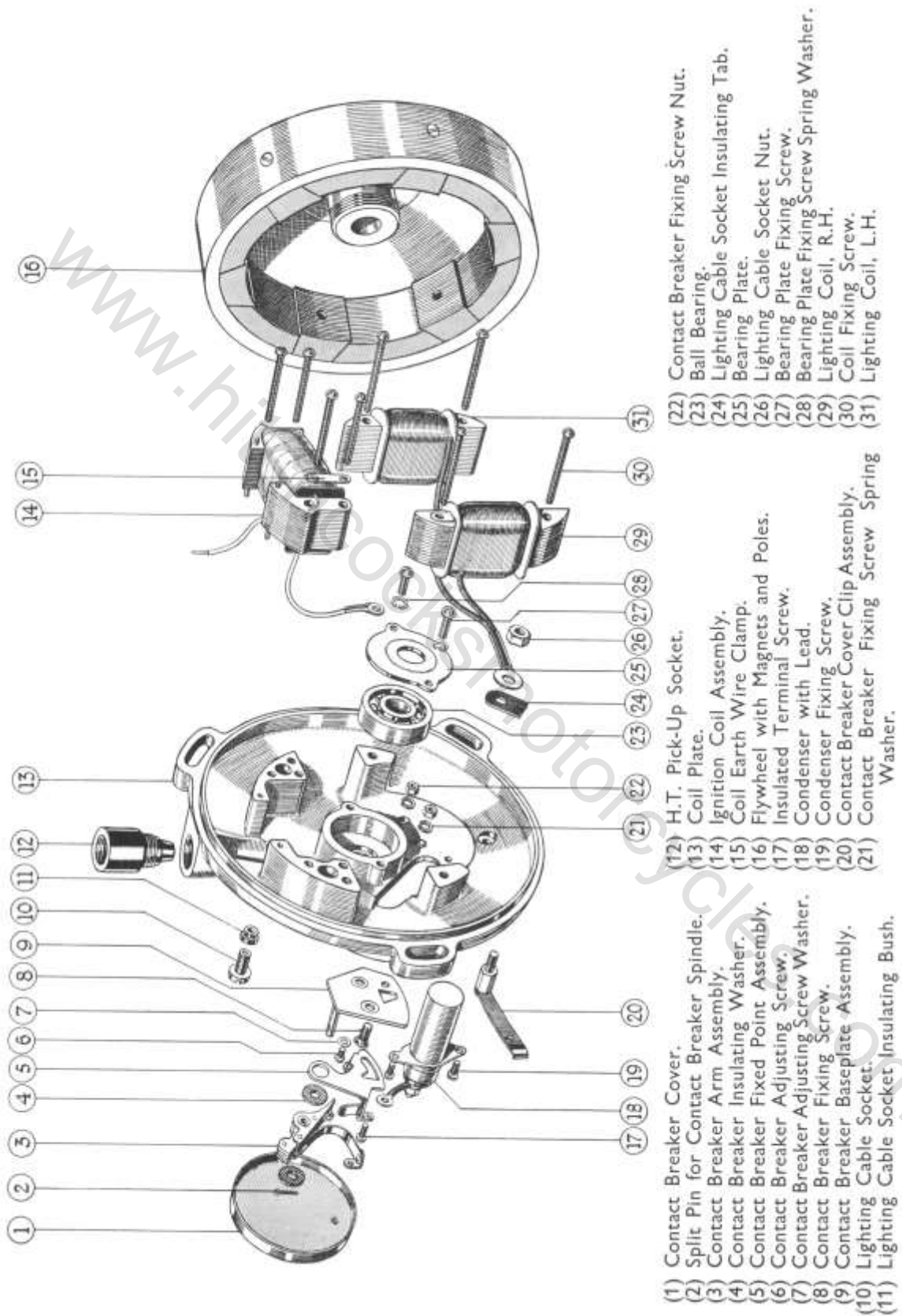

Fig. 43

ROYAL ENFIELD WORKSHOP MANUAL



EXPLODED VIEW OF MAGNETO.

Fig. 44

ROYAL ENFIELD WORKSHOP MANUAL

54. Adjustment of Contact Breaker. (See Fig. 43.)

To check the contact setting, turn the engine until the contacts are fully open and insert a feeler gauge .015 in. thick. A slight variation in the contact breaker gap is not important, but if there is an appreciable variation from the gauge, slacken the contact breaker adjusting screw (see Fig. 43), adjust the plate which pivots about the rocker arm centre and tighten the screw.

55. H.T. Cable.

This should be 7 mm. in diameter. Other sizes such as 5 mm. and 9 mm. will not fit in the H.T. connection to the magneto or in the waterproof cap on the plug. The H.T. cable must be replaced if the rubber insulation is perished or, shows cracks or has become brittle.

56. H.T. Connection.

The H.T. cable should pass right through the removable part of the H.T. connection and the strands of the cable should pass through the brass washer and then be splayed over and soldered to the washer.

To remove the H.T. connection socket from the coil plate, grip it firmly with a pair of pliers and unscrew the socket. When replacing, make sure that the lead from the ignition coil passes through the hole in the brass insert in the socket, and is then bent over.

57. Ignition Timing.

The ignition timing should be such that the contact breaker points are just about to open when the piston is $5/32$ in. - $3/16$ in. before the top of the compression stroke with the magneto coil plate central on its slots.* With this timing the magnet pole pieces are in the correct position relative to the ignition coil to give the best spark. After having timed the ignition correctly a slight amount of advance or retard in relation to the engine is then possible by moving the magneto coil plate round on its slots.* Turning the coil plate in a clockwise direction retards the ignition, anti-clockwise advances it. Movement of the coil plate does not affect the quality of the spark once the ignition has been correctly timed. For details of the method of altering the timing, see Para. 17.

58. Removal and Replacement of Magneto.

The method of removing the magneto coil plate and the flywheel is described in Para. 11. The method of replacing the magneto is described in Para. 17.

59. Dismantling the Magneto.

The construction of the magneto is clearly shown in Figs. 43 and 44. To dismantle the contact breaker, unscrew the insulated terminal screw (17) which secures the contact breaker spring and the two leads to the insulated terminal, remove the split pin (2) securing the contact breaker arm and lift away the insulating washer (4) and the arm complete with spring (3). The second insulating washer (4)

* The purpose of these slots is to allow the timing of the magneto relative to the engine to be varied slightly without affecting the timing relative to pole position. In practice they serve no useful purpose and tend to confuse the process of timing the magneto. The provision of the slots has, therefore, been discontinued.

can then be removed. Unscrew the contact breaker adjusting screw (6) and remove the fixed point assembly (5). If it is required to remove the baseplate of the contact breaker (9) this can now be done after unscrewing the two screws (8) which hold it to the aluminium coil plate (13). Note that these screws have nuts (22) and washers (21) behind the cover plate. The condenser (18) can now be removed by unscrewing the two screws (19) which secure it to the aluminium coil plate.

Removal of the ignition (14) and lighting coils (29 and 31) can now be effected quite readily after unscrewing the eight screws (30) which secure them to the coil plate.

If it is required to remove the ball bearing (23) held in the coil plate, first remove the two screws (27) which secure the steel plate (25) behind it, lift this plate away and knock the bearing out with a suitable drift.

Do not attempt to remove the magnets or pole pieces from the flywheel.

60. Test and Repair of Magneto.

The following tests may be carried out before removal of any of the fittings from the magneto coil plate :

Remove the magneto coil plate complete with fittings, connect the H.T. cable and sparking plug to the H.T. connector, lay the sparking plug so that the body makes contact with-but the terminal is clear of the coil plate and separate the contact breaker points with a piece of cardboard or other suitable insulating material. Take two leads from a 2-volt battery cell, hold one of these against the screw which secures the contact breaker spring and the two leads to the insulated terminal and hold the other lead against the magneto coil plate and remove it quickly. A spark should then occur at the plug points. Try this once or twice since the occurrence of a spark depends on the speed at which the contact between the lead and the coil plate is broken. If a spark is obtained the ignition system is in order with the possible exception of the contact points, the magnets or, of course, the timing. If no spark is obtained, remove the H.T. pick-up complete and see whether a spark can be obtained from the end of the wire from the coil to the inside of the threaded hole from which the pick-up socket has been removed. If a spark is obtained at this point but not at the plug points the fault lies either in the H.T. lead, or the plug. Check these by substitution.

If no spark can be obtained from the outlet wire from the coil the insulation of the coil and other components should be checked, for which purpose a MEGGER is necessary. The following figures should be obtainable :

End of outlet wire from coil, to coil plate. *Continuity*
(A high resistance indicates a break in the secondary winding necessitating replacement of the coil) ...

Centre of condenser to coil plate after removal of condenser lead from insulated terminal *Not less than 30 megohms*

Note. When making this test turn the handle of the MEGGER slowly so as not to put excessive voltage across the condenser. After carrying out this test it

ROYAL ENFIELD WORKSHOP MANUAL

should be possible to obtain a small spark from the centre terminal of the condenser across to a screwdriver held in contact with the magneto coil plate.

Insulated terminal to coil plate (after removal of contact breaker spring and lead from coil to insulated terminal

Not less than 200 megohms.

Outside winding of ignition coil to plate

Not less than 200 megohms.

If all the above are in order check the resistance of the secondary winding between the H.T. outlet wire and the magneto coil plate. This should be of the order of 2,500 ohms and can be checked with an ohmmeter or AVOMETER or a MEGGER with a switch for measuring resistance of this order. If the resistance differs greatly from this figure, the coil is faulty and must be replaced.

To check the resistance of the primary winding of the coil take one lead from a two-volt battery cell through an ammeter to the insulated terminal of the contact breaker. Separate the contact points by means of a piece of cardboard or other suitable insulating material and hold the other lead from the battery on to the coil plate. The ammeter should read approximately 4.1/2 - 5 amperes.

The strength of the magnets in the flywheel can be gauged by means of an ordinary ammeter such as is fitted to the headlamp used with most motor cycles. Fig. 45 shows a simple fixture for this purpose. The distance of the ammeter from the flywheel must be found by trial and should be such that approximately full scale deflection is obtained from a new flywheel. (For the standard ammeter fitted to a Lucas headlamp a distance of 14 ins. from the centre of the ammeter to the rim of the flywheel is suitable.) This device will not measure the strength of the magnets but forms a means of comparing a doubtful flywheel with one which is known to be satisfactory. It will be found on rotating the flywheel that one of the deflections is more powerful than

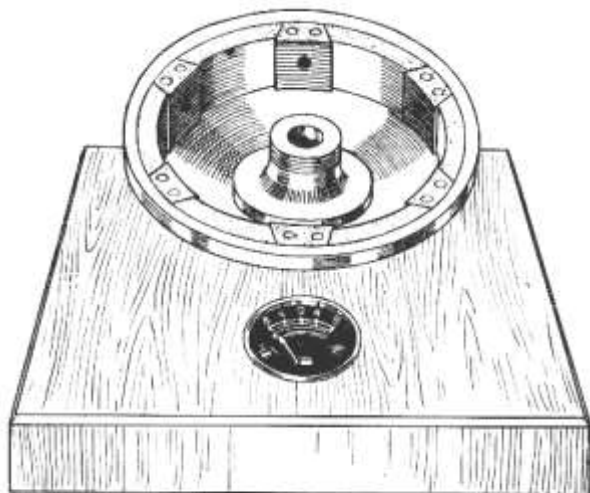

FIXTURE FOR TESTING MAGNETO MAGNETS.

Fig. 45

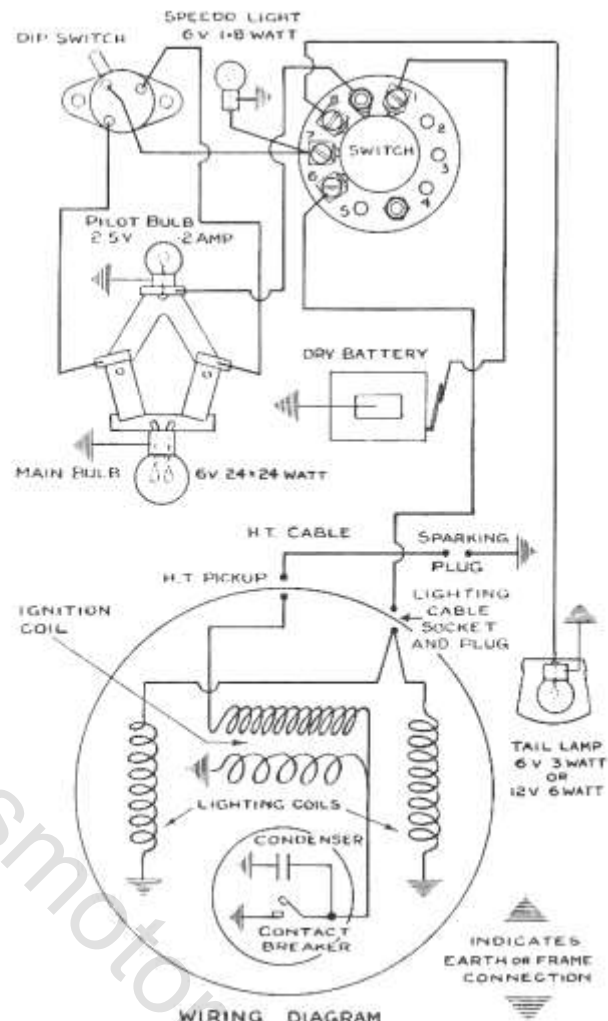

WIRING DIAGRAM

Fig. 46

the other five. This is due to the fact that different magnet material is used for the two magnets on either side of the pole piece in line with the keyway. These magnets are the ones used to provide the ignition current while the four weaker ones are used only for the lighting coils.

61. Reassembly of Magneto.

After replacing the ball bearings repack the housing with high melting point grease. If new contact breaker parts have been fitted, see that the points meet up correctly and, if necessary, set the arm carrying the fixed point to ensure this.

If the ignition coil has been replaced, make sure that it does not foul the poles on the flywheel. The poles on the end of the coil are normally machined after assembly of the coil plate and although spare coils are machined on a fixture corresponding to the coil plate, strict interchangeability cannot always be guaranteed. If the poles of the coil foul those on the flywheel, provide the necessary clearance by filing the poles on the coil taking care to remove all traces of filings before assembling the magneto.

ROYAL ENFIELD WORKSHOP MANUAL

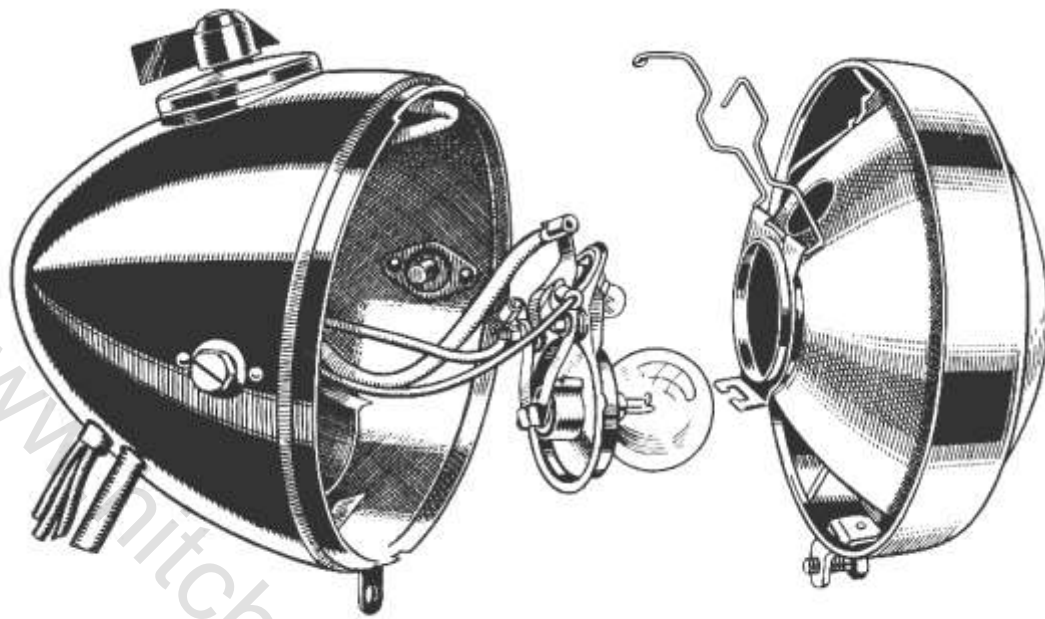

HEAD LAMP.

Fig. 47

SPARKING PLUG.

62. Type and Gap Setting.

The following plugs are recommended as being the most suitable for this machine :

Lodge CN, Champion J8, KLG F20.

With the exception of the KLG F20 these are of the nondetachable type, and if fouled with carbon or oil must be cleaned by sandblasting or other similar process.

Experience has shown that starting is likely to be difficult if the gap between the plug points exceeds .020 in. on the other hand, too small a gap causes erratic running particularly before the engine is fully warmed up. We recommend that the gap should be set to .015 in. which gives good running and a reasonable life before the gap becomes too wide for easy starting. When setting the gap always bend the side point, never the central electrode.

LIGHTING CIRCUIT.

63. Testing.

The head lights can be obtained only when the engine is running and the low tension connection is plugged into its socket. If, under these conditions, there is no response to switching on the lights, remove the low tension connection from the flywheel generator and connect it to one terminal of a 6-volt battery, earthing the other terminal. If the lights now respond correctly, the trouble is in the lighting coils in the flywheel generator (see Para. 64). If lights are still not available the trouble is either in the wiring circuit, the switch or the bulbs. The wiring diagram is shown in Fig. 46, and is so simple that it is hardly worth while testing the connections electrically, being probably easier to follow each lead through from end to end and make sure that it makes contact with the terminals and that its insulation is in good condition.

If certain lights are available but not others, e.g., headlamp but not the tail lamp, the trouble is most probably that one bulb is burnt out.

64. Lighting Coils, Testing.

Current for the lights is obtained from the lighting coils in the flywheel generator. These can be tested by connecting one terminal of a 2-volt battery to the inside of the insulated socket on the coil plate and the other terminal of the battery to the coil plate itself with an ammeter in the circuit. The current passed should be of the order of 13-14 amperes. Do not apply this current for more than a second or so as this test is practically a short circuit on the battery. If no current flows there is probably a break in one of the two coils which are connected in parallel.

Note. Remove the coil plate from the engine before carrying out this test, otherwise demagnetisation of the flywheel will occur.

HEADLAMP. (Miller Type 62 ED.)

65. Removing Lamp Front and Reflector.

To remove the lamp front and reflector undo the screw at the bottom of the lamp. (See Fig. 47.) When replacing the front locate the top of the rim first then engage the screw and tighten it securely.

To remove the bulb holder release the securing springs and push them gently apart so that the holder can be withdrawn from the reflector.

To remove the reflector from the lamp front release the four securing spring clips inside the rim of the lamp, after which the reflector together with the bulb holder can be lifted away. When replacing the reflector, make sure that it is the right way up with the pilot lamp at the top.

ROYAL ENFIELD WORKSHOP MANUAL

66. Setting and Focusing.

The lamp must be set to ensure that the main beam is projected horizontally and the dipped beam below the horizontal. There is no means of focusing the bulb which is correctly placed in the position to give the best results. Make sure that the main bulb is fitted the right way round, one side of the cap is clearly marked "TOP."

67. Cleaning.

Care must be taken when handling the reflector to prevent it becoming finger-marked. It can, however, be cleaned by polishing with a fine chamois leather. Metal polishes must not be used.

68. Bulbs.

The main bulb must be 6-volt, 24 X 24 watt double filament.

The pilot bulb is 2.5 volt, 0.2 amp. A bulb of lower amperage may be used if available, but larger amperage bulbs should be avoided as they will quickly exhaust the dry battery.

TAIL LAMP. (Miller Type 36E.)

69. To Remove the Bulb.

To obtain access to the bulb remove the wire circlip and lift away the chromium plated fret and the ruby disc. The bulb can now be removed in the normal manner.

The bulb fitted as standard is 6 volt, 3 watt. If trouble is experienced with the bulb burning out at high engine speeds it is permissible to use a 12-volt, 6 watt bulb which will not give such a bright light at the rear and a rather brighter light from the head lamp.



TAIL LAMP.

Fig. 48

SPEEDOMETER LIGHT.

70. Bulb.

The bulb fitted to this is 6 volt, 1.8 watt. This bulb is arranged to light only when the engine is running and the head light is switched on, thus preventing waste of current from the dry battery.

PARKING BATTERY.

71. Dry Battery.

The head lamp is arranged to accommodate a standard twin cell cycle type of dry battery. When the battery becomes exhausted it should be removed as it will otherwise cause corrosion to occur inside the lamp.

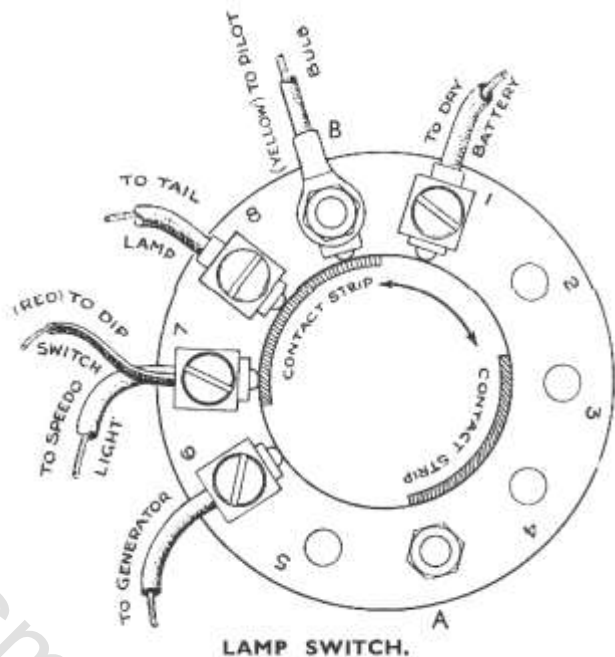

LAMP SWITCH.

Fig. 49

LIGHTING SWITCH.

72. Operation of Switch.

The connections to the switch are shown in Fig. 47, which also shows the contacts. As shown, the switch lever is in the "OFF" position. Both the dry battery and the lead from the generator are isolated so that no current flows.

When the moving contacts are turned one division in an anti-clockwise direction the lead from the generator is connected to the tail lamp, speedometer bulb and through the dip switch to the main bulb.

When the contacts are turned one division in a clockwise direction from the position shown the dry battery is connected to the tail lamp and the pilot bulb.

To remove the switch from the lamp first remove the lamp front and reflector then remove the nuts from terminals "A" and "B" and the centre screw which secures the switch control lever to the centre. The body of the switch can now be withdrawn into the lamp and the top and lever lifted away from the outside. When replacing do not omit the washer between the top of the switch and the body of the lamp.

ROYAL ENFIELD WORKSHOP MANUAL

LUBRICATION CHART

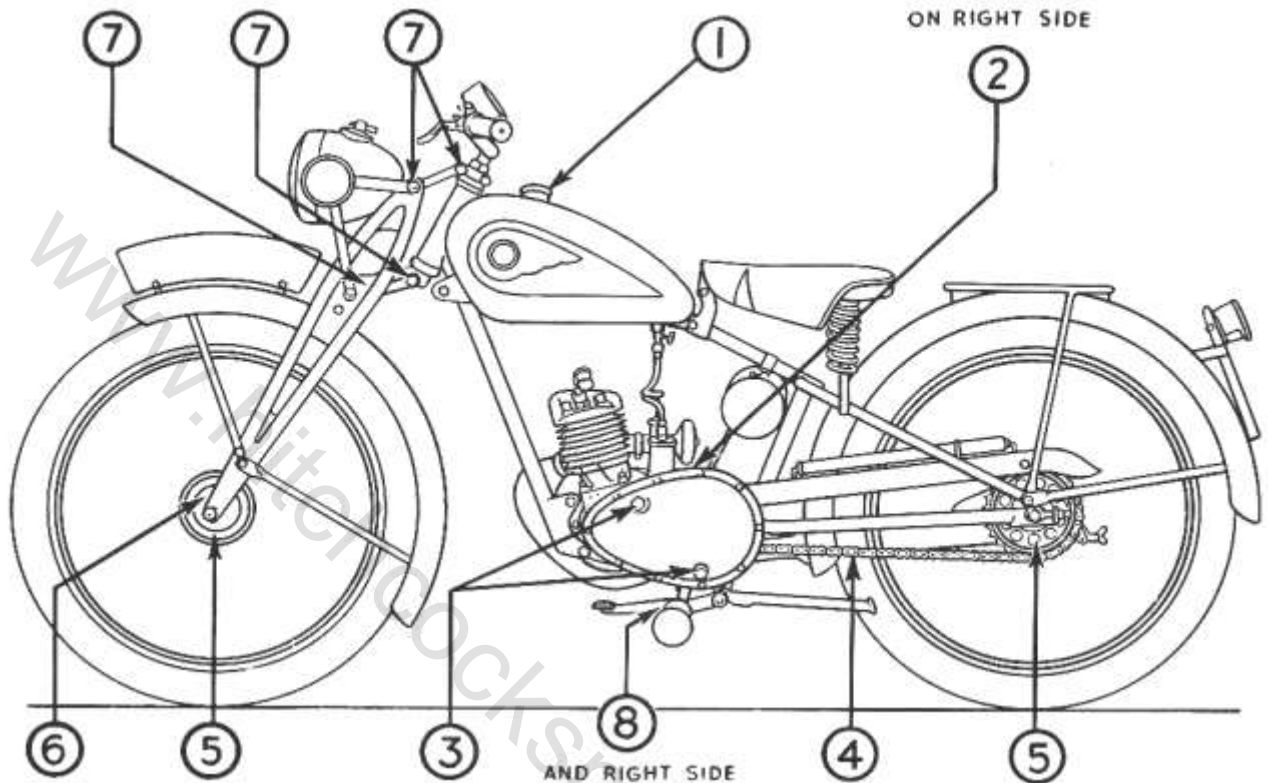

Location No.	Part	Lubricant
1	PETROL TANK FILL UP (2 measures per Gallon)	Castrol Grand Prix
2	GEAR BOX TOP UP (Capacity ¼ pint)	Golden Shell
3	CHAIN CASE TOP UP	Mobiloil D
		Essolube Racer
		Energol S.A.E. 60
4	REAR CHAIN	Engine Oil or Grease
5	WHEEL HUBS	Castrolase (Heavy)
6	SPEEDOMETER DRIVE	Mobilgrease (No 4)
		Shell Retinax R.B. Grease
		Esso Grease
		Belmoline C
7	FORK SWIVEL PINS (5 points)	Castrolase (Medium)
8	BRAKE PEDAL PIVOT (2 points)	Mobilgrease (No 2)
		Shell Retinax C.D.
		Esso Grease
		Belmoline D
	OIL CAN LUBRICATION	
	Control Levers and Rods and exposed ends of control cables.	Engine Oil

ROYAL ENFIELD WORKSHOP MANUAL

DATA

ENGINE.			Clearance in Clutch Control		1/16 in.
Cubic Capacity		125 c.c.	Gearbox Ball Bearings-		
Stroke		55 m.m.	Internal Diameter		20 m.m.
Bore		54 m.m.	External Diameter		47 m.m.
Compression ratio		5½ to 1	Width		14 m.m.
PISTON			Gearbox Mainshaft Bush Internal		
Bottom of Skirt-			Diameter (reamered after fitting)		.5005 in.- .5000 in.
	Fore and Aft	2.1215 ins.- 2.1210 ins.	Gearbox Layshaft Bushes Internal		
	Sides	2.117 ins- 2.116 ins.	Diameter (reamered after fitting)		.5005 in.- .5000 in.
Top of Skirt-			Gearbox Kickstarter Spindle Bush		
	Fore and Aft	2.1200 ins.- 2.1195 ins.	Internal Diameter reamed after fitting)		.8130 in. - .8125 in.
	Sides	2.1160 ins.- 2.1155 ins.	FRAME AND WHEELS.		
	Middle Land	2.112ins- 2.110ins.	Wheel Hub Bearings		Internal Diameter
	Top Land	2.107 ins.- 2.105 ins.	External Diameter		30 m.m.
Piston Ring Dimensions-			Width		9 m.m.
	Width	1/8 in.	Wheel Rim Size-		W.M.O. 19 in.
	Radial Thickness	.08 in.	<i>Front and rear rims interchangeable.</i>		
	Gap in Unworn Cylinder	.012 in.- .008 in.	Wheel Spokes-		
	Clearance in Grooves	.006 in.- .003 in.	Front, brake side		7.15/16 in. long.
Oversize Piston and Rings available		.015 in. and .030 in.	Front, other side		8.13/16 in. long.
Piston Boss Internal Diameter		.496 in. - .4955 in.	Rear, brake side		7.3/8 in. long.
Gudgeon Pin Diameter		.496 in. - .4955 in.	Rear, other side		8.11/16 in. long.
Small End Bush Internal Diameter			<i>Spoke length measured centre of head to end of thread.</i>		
(fine bored or reamed after fitting)		.4975 in.- .4765 in.	Brake Linings-		
Big End Internal Diameter		1.2238 ins.- 1.2234 in.	Front		3.3/4 in. dia. x 1/2 in. wide x 1/8 in. thick.
Crankpin Diameter (centre portion)		.7238 in.- .7234 in.	Rear		5 in. dia. x 5/8 in. wide x 3/16 in. thick.
Roller Diameter		.2500 in.- .2492 in.	Steering Head Balls-		3/16 in. dia., 44 to set
(Graded to nearest .0001 in. and selective assembly used).			Material Ferodo MW.		(22 each race).
Crankcase Bearings			CARBURETTOR.		
Large-	Internal Diameter	15 m.m.	Type and Number		Amal type 223/001CD
	External Diameter	42 m.m.	Jet Sizes, Main		90
	Width	13 m.m.	Needle Jet		107
Small-	Internal Diameter	15 m.m.	Taper Needle Position		Clip in No. 2 or No. 3 groove.
	External Diameter	35 m.m.	IGNITION.		
	Width	11 m.m.	Contact Breaker Maximum Opening		.015 in.
Crankcase Sealing Bushes Internal Diameter			Ignition Setting		5/32 in.-3/16 in. before t.d.c.
(reamered after fitting)		.594 in.	30° advance		
Flywheel Magneto Bearing			Sparking Plug- Size		14 m.m. x 1/2 in. reach
Internal Diameter		10 m.m.	Type		Lodge CN, Champion J.8 or K.L.G. F.20
External Diameter		30 m.m.	Gap Setting		.015 in.-.018 in.
Width		9 m.m.	GENERAL.		
TRANSMISSION.			Petrol Tank Capacity		1.1/2 gallons
Sprockets-	Engine	14 T. x 3/8 in. P. x .225 in. W.	Petrol-Oil Mixture		24-1.
	Clutch	44 T. x 3/8 in. P. x .225 in. W.	(2 measures oil to each gallon petrol)		
	Gearbox	14 T. x 1/2 in. P. x .205 in. W.	Gear Box Capacity		1/4 pint
	Rear Wheel	34 T. x 1/2 in. P. x .205 in. W.	Chain Case Capacity		1/8 pint
Chains-			<i>All Nuts on this Machine have R.H. Threads.</i>		
Front (Renolds No. 110038)					
58 pitches, 3/8 in. P. x .225 in. W. x .250 in. roller dia.					
Rear (Renolds No. 110044)					
103 pitches, 1/2 in. P. x .205 in. W. x .335 in. roller dia.					
Chain Adjustment-	Front	1/4 in. (to 3/4 in.) slack.			
	Rear	½ in. slack.			
Gear Ratios-	First	22.35 to 1			
	Second	12.40 to 1			
	Top	7.64 to 1			
Clutch Thrust Rod Length		Short part- 1.1/8 ins.			
		Long part- 3.7/8 ins.			
		Pad- 1.7/8 ins.			

ROYAL ENFIELD WORKSHOP MANUAL

INDEX

	A	Para.	Page		G	Para.	Page
Air Cleaner		50	31	Gearbox, Dismantling		20	17
	B			Operation of		19	16
Bearing, Big End		6, 13-15	7, 12	Reassembling		23	20
Gearbox		21, 22	17	Sprocket		11, 19, 20	10,16,17
Magneto		59	34	Gear Control Quadrant		38	26
Small End		7, 13	7, 12	Gudgeon Pin		3, 7	6, 7
Bearings, Crankcase		16	13		H		
Wheel		35	22	Head Lamp		65-68	36
Brakes		34	22	High Tension Cable		55	34
				Connection		56	34
	C				I		
Carbon, Removal of		4	6	Ignition Timing		17, 57	14, 34
CARBURETTOR		46-51	30	Inlet Port		1	5
Method of Tuning		48	30		K		
Construction of		47	30	Kickstarter Crank		11, 17	10, 14
Standard Setting		48	30		L		
Troubles		49	31	Lamp Bulbs		68-70	37
Chain Cover, Front		11, 17	10, 14	Lighting Circuit, Testing		63	36
Front		17	14	Coils		64	36
Guard, Rear		10	10	LIGHTING AND IGNITION SYSTEM		52-72	32
Chains		26-29	21	Lighting Switch		72	37
Limits of Wear		28	21	Lubrication Chart			38
Lubrication		26	21		M		
Removal, Repair and Replacement		29	21	Magneto		52-61	32
Tensioning		27	21	Coil Plate		11, 17	10, 14
Circlips		3	6	Dismantling		59	34
Clutch		24, 25	20	Flywheel		11, 17	10, 14
Centre, Removal		11	10	Operation of		52	32
Control		25	20	Reassembling		61	35
Dismantling		11	10	Removal and Replacement		58	34
Connecting Rod		13	12	Test and Repair		60	34
Contact Breaker, Adjustment		54	34	Timing		17, 57	10, 34
Cam		11, 17	10, 14		P		
Cleaning and Lubricating		53	32	Parking Battery		71	37
Control Levers, Handlebar		45	39	Petrol Consumption, Reasons for Excessive		51	31
Crankcase, Dismantling		11	10	Petrol Tank, Method of Attachment		37	26
Reassembling		17	14	Pipe		2	5
Studs, Lengths of		17	14	Piston		5, 9	6, 10
Crankshaft, Dismantling		12	12	Removal		3	6
Reassembling		15	12	Rings		4, 5, 9	6, 10
Cylinder Dimensions		5	6		R		
Head, Removal		2	5	Rollers, Big End Bearing		14	12
Replacing		9	10		S		
Removal		2	5	Sealing Bushes		16	13
Replacing		9	10	Silencer		4	6
				Sparkling Plug		62	36
	D			Cleaning and Setting		62	36
DATA			39	Type		62	36
Decarbonising		2-9	5	Speedometer Light		70	37
Decompressor		8	7	Sprocket, Rear Wheel		36	36
Control		2, 9	5, 10	Steering Head, Adjustment		40	26
				Dismantling & Reassembling		41	26
	E				T		
ENGINE		1-18	5	Tail Lamp		69	37
Complete overhaul		10-18	10	Transfer Ports		1, 4	5, 6
Decarbonising		2-9	5	TRANSMISSION		19-36	16
& Gear Unit, Removal from Frame		10	10	Twist Grip, Adjusting		45	29
& Gear Unit, Replacing in Frame		18	15	Tyres		31	22
Principle of Operation of		1	5		W		
Reassembly after Decarbonising		9	10	Wheel Bearings		35	22
Sprocket		11	10	Rims		32	22
Exhaust Port		1, 4	5, 6	Spokes		33	22
				WHEELS		30-36	22
	F			Alignment of		39	26
Fork Links, Adjustment		42	27	Removal and Replacement		30	22
Suspension Rubbers, Replacing		43	27				
Front Fork, Dismantling		44	29				
FRAME AND FORK		37-45	26				



SPARES for ROYAL ENFIELD & AMAL

**HITCHCOCK'S MOTORCYCLES
ROSEMARY COURT
OLDWICH LANE WEST
CHADWICK END
SOLIHULL
B93 0EY ENGLAND**

**TELEPHONE: 01564 783 192
FAX: 01564 783 313**

**E-MAIL: info@hitchcocksmotorcycles.com
WEB: hitchcocksmotorcycles.com**