

Fitting instructions for the Café racer seat, mudguard and fixing kit. (92512)

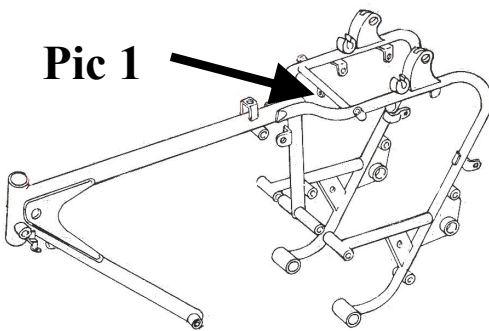

The café racer seat and mudguard kit contains all the parts necessary to assemble and fit to the Indian made Bullets (excluding the 500 Electra models). Following the removal of the original seat, rear mudguard (both sections) and support brackets, the new seat unit may now be fitted utilizing the original seat front fixing points "A" and the rear suspension top mounting bolts "B" (Pic 2). The lower fixing point of the replacement short alloy mudguard attaches to the bracket where shown in Pic 1



Pic 1

Pic 2



Pic 3

Assembly of the seat, brackets and short mudguard are shown in "Pic 3", particular attention being paid to the direction of the brackets and the angle of the mounting points as shown in "Pic 4"

Included in the kit is a 1960's style rear light which can be fitted in place of the original light., (the seat unit will require simple drilling to accept the light of your choice). Also included are 2 clips for securing the tail light electric harness if necessary.

If Indicators are to be fitted, these are best fitted to the rear bracket "C" (Pic 4) which will require drilling to suit. We do not recommend attaching to the fibreglass part of the seat.

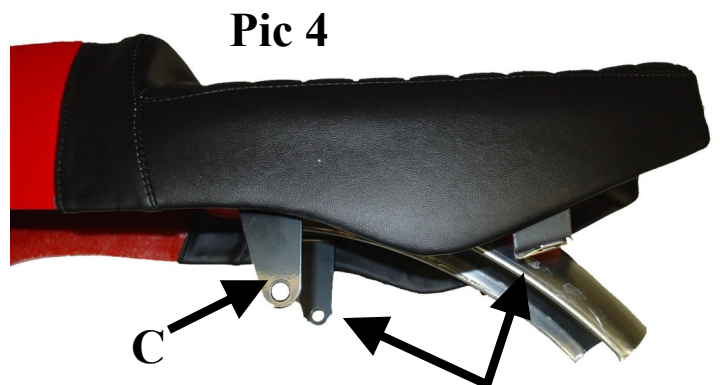

Pic 4

Note angle of brackets