



SPARES for ROYAL ENFIELD & AMAL

EMAIL: info@hitchcocksmotorcycles.com
WEB: www.hitchcocksmotorcycles.com

HITCHCOCK'S MOTORCYCLES LTD
ROSEMARY COURT
OLDWICH LANE WEST
CHADWICK END
SOLIHULL
B93 0EY ENGLAND

TELEPHONE: **01564 783 192**
FAX: **01564 783 313**

92110 Spot Lights and Bracket (55 Watt Bulbs)

The Kit Comprises

- Spotlight Mounting Bar complete with Nuts, Bolts and Washers
- Relay
- Wire, Connectors and Insulators
- Handlebar mounted On/Off switch
- Two Spot Lights

Mount the Spotlight Mounting Bar into the bottom yoke using the supplied extended nuts, bolts and spacers.

Mount the Spotlights onto the bar using washers and nyloc nuts.

Mount the Relay at a convenient place, ideally in the toolbox.

Mount the On/Off switch onto the handlebars. This is a dip switch and acts as the on/off Override Switch, connect the feed to terminal marked "3" and the output to either of the other two terminals.

Wire the Spotlights as per the diagram below. For neatness we recommend taking the lamp wires through the Mounting Bars and into the casquette.

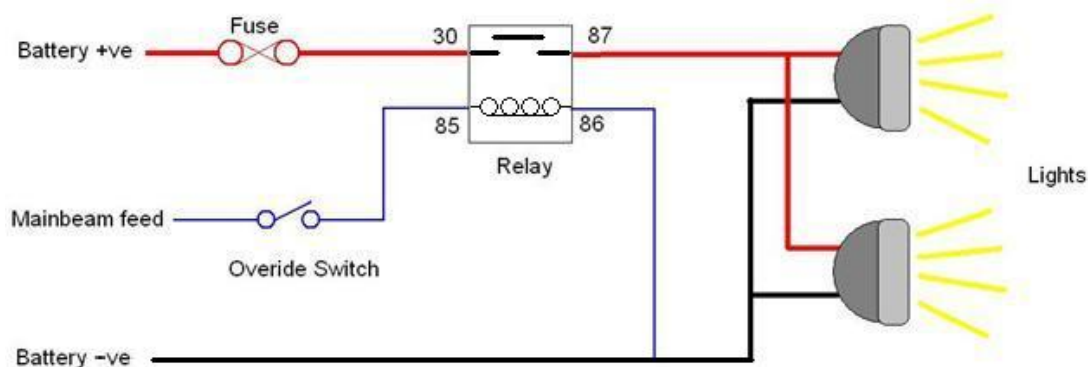

Wiring Diagram for Negative Earth